

Series F Shaft Mounted Helical

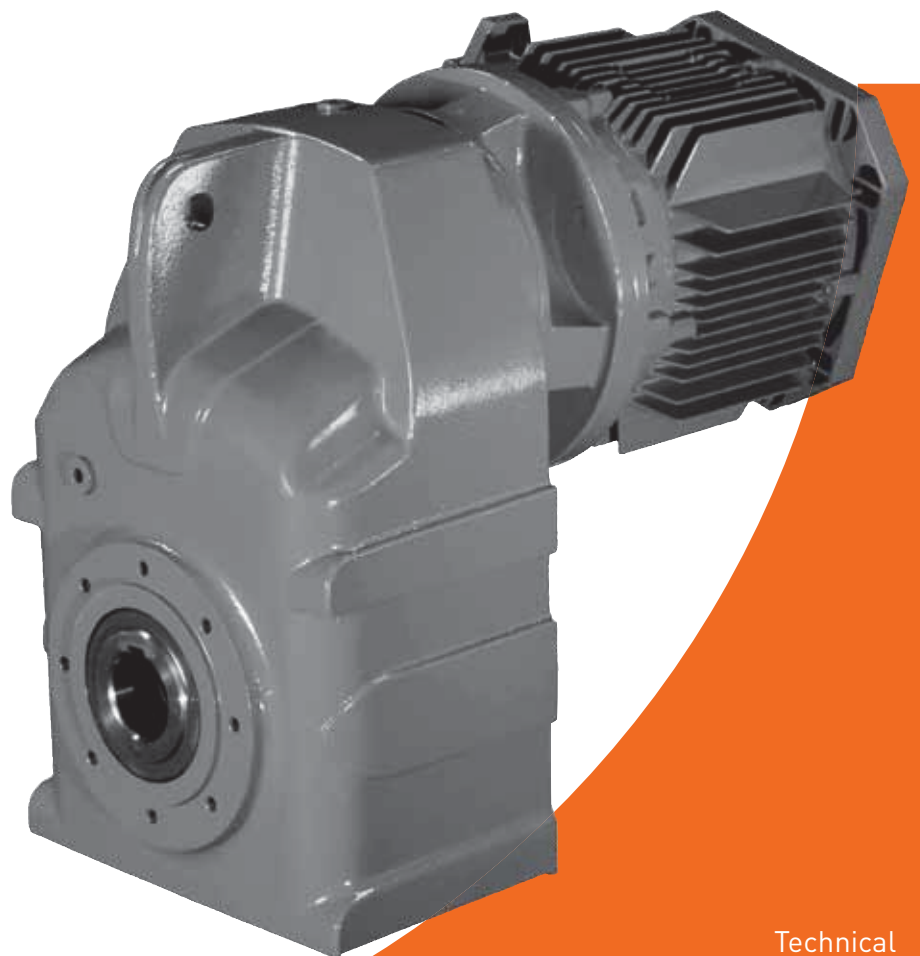

Technical
Up to - 110 kW / 16,500 Nm
Geared Motors
CF-2.01GB0114

ATEX

Compliance Assured



Total compliance with the ATEX Directive safeguarding the use of industrial equipment in potentially explosive atmospheres is assured for users of our geared products.

Certification is available for standard gearboxes and geared motors with badging displaying the ATEX zone, name and location of the manufacturer, designation of series or type, serial number, year of manufacture, Ex symbol and equipment group/category.

ATEX directive 94/9/EC (also known as ATEX 95 or ATEX 100A) enforced in all EC member states. Compliance is compulsory for designers, manufacturers or suppliers of electrical and non-electrical equipment for use in potentially explosive atmospheres created by the presence of flammable gases, vapours, mists or dusts.

Ex compliant standard gearboxes can be supplied against Groups 2 or 3 for surface industries in designated hazardous location Zones 1 and 2 for gases, vapours and mists; and in Zones 21 and 22 for dusts.

SERIES F

NOTES

General Description _____	1
Unit Designations _____	2
Explanation and use of Ratings and Service Factors _____	3
Load Classification by Applications _____	4
Selection Procedure For Motorised Units _____	5 - 6
Output Options _____	7 - 8
Motor Adaptors _____	9 - 11
Lubrication _____	12
Mounting Positions _____	13
MOTORISED	
Motor Performance Data _____	15
Motor Details _____	16
Additional Motor Features _____	17
Additional Gearbox Features _____	18
Exact Ratios _____	19 - 20
Selection Tables Geared Motors _____	21 - 70
Dimensions Motorised _____	71 - 72
Motorised Backstop Module _____	73
Dimensions Motorised Options _____	74
REDUCER	
Overhung & Axial Loads on Shafts _____	77
Thermal Power Ratings _____	78
Double Reduction Ratings _____	79 - 86
Triple Reduction Ratings _____	87 - 89
Quadruple Reduction Ratings _____	90 - 95
Dimensions Reducer _____	96 - 97
Fan Cooled Units _____	98
Reducer Backstop Modulle _____	99
Kibo Bushes _____	100 - 101
Torque Bush _____	102
Dimensions D Flange _____	103
Dimensions C Flange _____	104
Dimensions Standard Bore Assembly _____	105
Dimensions Standard Bore Disassembly _____	106
Shipping Specification _____	107 - 109
Product Safety Data _____	110

SERIES F

GENERAL DESCRIPTION

Series F

Series F shaft mounted geared motors offer ratios from 5 to 100/1 in double reduction, from 100 to 360 in triple and up to 5600/1 in combined reductions. Motors are available up to 110 kW giving a maximum output torque of 16500 Nm.

The series F geared motor is primarily designed as a shaft mounted unit incorporating an integral torque reaction bracket. The units are also available with rubber torque bushes, output flanges, output shafts and KIBO sleeves to allow for trouble free maintenance.

All variants can be fitted with IEC motors of your preference or with our standard own brand motor. Input shaft assemblies are available up to and including F10.

The Range Includes

Ten sizes of units
F02, F03, F04, F05 F06, F07, F08, F09, F10, F11 and F12.

Version T - Standard unit with torque bush
Version W - Standard unit without torque bush
Version F - Standard unit with output flange

Unit type M - Motorised
Unit type G - Unit to allow fitting of a standard IEC motor
Unit type A - Unit to allow fitting of NEMA motor

Unit type R - Reducer
Unit type S - Reducer unit fitted with a fan
Unit type X - Reducer unit fitted with a backstop
Unit type Y - Reducer unit with a fan & backstop

Design Features Include

Patented standard motor connection (IEC or NEMA).

Ability to fit double oil seals on output shaft as required.

All units are dimensionally interchangeable with other major European manufacturers.

Brake geared motors are available as standard.

Units are manufactured and assembled from a family of modular kits for distributor friendliness maximising availability and flexibility.

Motorised units can be fitted with a backstop module and reducer units can be fitted with a backstop and fan.

As improvements in design are being made continually this specification is not to be regarded as binding in detail and drawings and capacities are subject to alteration without notice. Drawings and 3D-models are available at <http://www.swift-gears.com>

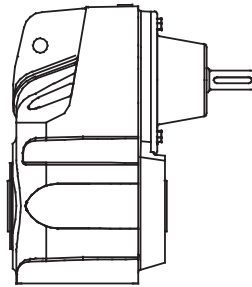

Double reduction/triple shaft mounted reducer

* F 0 4 2 2 5 0 . T R H - 1 - - - - - - -

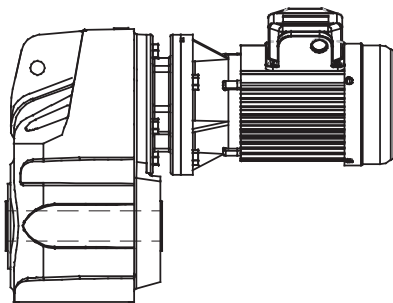

Motorised double/triple reduction shaft mount

* F 0 4 2 2 5 0 . T M H - 1 A . 7 5 A - -

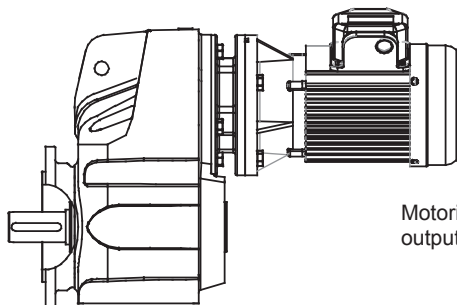

Motorised double/triple reduction with output shaft and flange

* F 0 4 2 2 5 0 . F M C - 1 A . 7 5 A - -

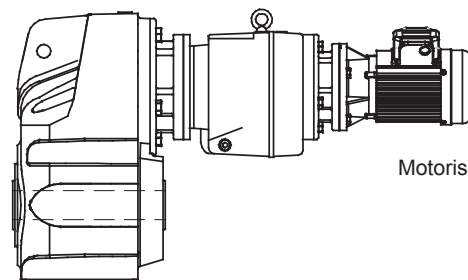

Motorised quadruple shaft mount

* F 0 6 4 2 5 0 0 T M H - 1 A . 1 2 A - -

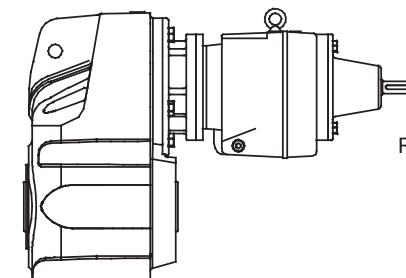

Reducer quadruple shaft mount

* F 0 6 4 2 5 0 0 T R H - 1 - - - - - - -

* Typical Unit Designations

UNIT DESIGNATIONS

Gearbox Codes													Motor Codes							
Series	Size of Unit			No of Reductions	Revision Version	Nominal Overall Ratio			Unit Version	Type of Unit	Output Shaft	Motor Adaptor	Mounting Position	Geared Motor Power	No of Motor Poles	Additional Motor Features	Additional Gearbox Features			
1	2	3	4	5	6	7	8	9	10	11	12	13	14	15	16	17	18	19	20	
F																				
F	0	8	2	2	5	0	.	T	M	C	F	1	D	3	.	0	A	-	-	

*
Example

20 - Additional Gearbox Features
Double Oil Seal, Motorised Backstop etc

e.g. See Page 18

1 - Series F

Range

2, 3 - Size of Unit

Through

4 - No of Reductions

Through

F11 and F12 in 2 and 3 reductions only

5 - Revision Version

For Sizes 02 to 08

For Sizes 09 to 12

6, 7, 8 - Nominal Overall Ratio

e.g.

9 - Unit Version

Standard Unit with Torque Bush

STD Unit without Torque Bush

STD Unit with Output Flange

10 - Type of Unit

- Motorised with IE2 standard motor
- Motorised with EPACT standard motor
- Motorised with IEC high efficiency motor (IE3)
- Motorised with NEMA high efficiency motor (PREMIUM)
- Unit to allow fitting of IEC motor (customer own motor)
- Unit to allow fitting of NEMA motor (customer own motor)
- Reducer unit
- Reducer unit with fan kit
- Reducer unit with backstop CCW rotation
- Reducer unit with backstop CW rotation
- Reducer unit with fan and backstop CW rotation
- Reducer unit with fan and backstop CCW rotation

19 - Additional Motor Features

e.g. See Page 17

For Types Without Motor Enter

18 - No of Motor Poles

No motor

	50 Hz	60 Hz
4 Pole (Std) 1500 rpm	<input type="text" value="A"/> 1800 rpm	<input type="text" value="B"/>
4 Pole (High) 1500 rpm	<input type="text" value="K"/> 1800 rpm	<input type="text" value="L"/>
6 Pole (Std) 1000 rpm	<input type="text" value="C"/> 1200 rpm	<input type="text" value="D"/>
6 Pole (High) 1000 rpm	<input type="text" value="M"/> 1200 rpm	<input type="text" value="N"/>
2 Pole 3000 rpm	<input type="text" value="E"/> 3600 rpm	<input type="text" value="F"/>
8 Pole 750 rpm	<input type="text" value="G"/> 900 rpm	<input type="text" value="H"/>

Dual speed or special motor

15, 16, 17 - Geared Motor Powers

Motor Power Required

e.g.

For reducer and non standard motor types enter

13, 14 - Mounting Position

e.g. See Page 13

12 - Motor Adaptor For Unit Types Column 10 Entries

A, E, G, H, M & N, Enter eg

For R, S, W, X, Y & Z Enter

11 - OUTPUT SHAFT

Standard Single Extension

F02 - F10 Only Standard Hollow Shaft

Standard Kibo Shaft - entry depends on shaft diameter

*This Page May Be Photocopied Allowing The Customer To Enter Their Order
To access the on line configurator please visit www.radicon.com

SERIES F

EXPLANATION & USE OF RATINGS & SERVICE FACTORS

Gear unit selection is made by comparing actual loads with catalogue ratings. Catalogue ratings are based on a standard set of loading conditions, whereas actual load conditions vary according to type of application. Service Factors are therefore used to calculate an equivalent load to compare with catalogue ratings.

i.e. Equivalent Load = Actual Load x Service Factor

Mechanical ratings and service factors Fm and Fs

Mechanical ratings measure capacity in terms of life and/or strength, assuming 10 hr/day continuous running under uniform load conditions.

Catalogue ratings allow 100% overload at starting, braking or momentarily during operation up to 10 hours per day.

The unit selected must therefore have a catalogue rating at least equal to half maximum overload.

Mechanical Service Factor Fm (Table 1) is used to modify the actual load according to daily operating time, and type of loading.

Load characteristics for a wide range of applications are detailed in Table 3 opposite, which are used in deciding the appropriate Service Factor Fm from Table 1.

If overloads can be calculated, or accurately assessed, actual loads should be used instead of Fm.

For units subjected to frequent stop/starts overloads in excess of 10 times/day multiply factor Fm x Factor Fs (table 2).

For applications where units are to operate in extremely dusty or moist/humid atmospheres unit selection should be referred to application engineers.

Table 1. Mechanical Service Factor (Fm)

Prime mover	Duration of service- hrs per day	Load classification-driven machine		
		Uniform mass acceleration factor ≤ 0.2	Moderate mass acceleration factor ≤ 3	Heavy mass acceleration factor ≤ 10
Electric motor, steam turbine or hydraulic motor	Under 3	0.80	1.00	1.50
	3 to 10	1.00	1.25	1.75
	Over 10	1.25	1.50	2.00
Multi-cylinder internal combustion engine	Under 3	1.00	1.25	1.75
	3 to 10	1.25	1.50	2.00
	Over 10	1.50	1.75	2.25
Single cylinder internal combustion engine	Under 3	1.25	1.50	2.00
	3 to 10	1.50	1.75	2.25
	Over 10	1.75	2.00	2.50

$$\text{Mass acceleration factor} = \frac{\text{all external moments of inertia}^*}{\text{moment of inertia of driving motor}}$$

* calculated with reference to the motor speed

Table 2. Number of Starts Factor (Fs)

Start / Stops per hour (1)	Up to 1	5	10	40	60	≥ 200
Factor Fs	1.00	1.03	1.06	1.10	1.15	1.20

Note: (1) Intermediate values are obtained by linear interpolation

SERIES F

LOAD CLASSIFICATION BY APPLICATIONS

Table 3

U = Uniform load

M = Moderate shock load

H = Heavy shock load

† = Refer to Application Engineering

		Driven Machine	type of load	Driven Machine	type of load	Driven Machine	type of load
		Cranes main hoists bridge travel trolley travel	† † †	log haul-incline log haul-well type log turning device main log conveyor off bearing rolls planer feed chains planer floor chains planer tilting hoist re-saw merry-go-round conveyor roll cases slab conveyor small waste conveyor-belt small waste conveyor-chain sorting table tipple hoist conveyor tipple hoist drive transfer conveyors transfer rolls tray drive trimmer feed waste conveyor	H H H H M M M M M H H H M M M M M M M M M	log haul presses pulp machine reel stock chest suction roll washers and thickeners winders	H M M M M M
		Crusher ore stone sugar	H H H	Dredges cable reels conveyors cutter head drives jig drives manoeuvring winches pumps screen drive stackers utility winches	M M H H M M M M M	Printing presses	†
		Dry dock cranes main hoist auxiliary hoist boom, luffing rotating, swing or slew tracking, drive wheels	† † † † †	Machine tools bending roll punch press-gear driven notching press- belt driven plate planers tapping machine other machine tools main drives auxiliary drives	M H † H H M U	Pullers barge haul	H
		Elevators bucket-uniform load bucket-heavy load bucket-continuous centrifugal discharge escalators freight gravity discharge man lifts passenger	U M U U U U U †	Metal mills draw bench carriage and main drive pinch, dryer and scrubber rolls-reversing slitters table conveyors non-reversing group drives individual drives reversing wire drawing and flattening machine wire winding machine	M M † M M M H M M	Pumps centrifugal proportioning reciprocating single acting; 3 or more cylinders double acting; 2 or more cylinders single acting; 1 or 2 cylinders double acting; single cylinder rotary gear type lobe, vane	U M M M † † U U
		Fans centrifugal cooling towers induced draft forced draft induced draft large, mine, etc large, industrial light, small diameter	U U † † M M M U	Mill-rotary type ball cement kilns dryers and coolers kilns, other than cement pebble rod plain wedge bar tumbling barrels	M H H H H H H	Rubber and plastics industries crackers laboratory equipment mixed mills refiners rubber calenders rubber mill-2 on line rubber mill-3 on line sheeter tire building machines tire and tube press openers tubers and strainers warming mills	H M H M M M † † M M M
		Feeder apron belt disc reciprocating screw	M M U H M	Mixers concrete mixers -continuous concrete mixers -intermittent constant density variable density	M M M U M	Sand muller	M
		Food industry beef slicer cereal cooker dough mixer meat grinders	M U M M	Oil industry chillers oil well pumping paraffin filter press rotary kilns	M † M M	Sewage disposal equipment bar screens chemical feeders collectors dewatering screws scum breakers slow or rapid mixers thickeners vacuum filters	U U U M M M M M
		Generators-not welding	U	Paper mills agitators, (mixers) barker-auxiliaries- hydraulic barker-mechanical barking drum beater and pulper bleacher calenders calenders-super converting machine, except cutters, platers conveyors couch cutters-plates cylinders dryers felt stretcher felt whipper jordans	M M M H H M U M H M M M M H M	Screens air washing rotary-stone or gravel travelling water intake	U M U
		Hammer mills	H	Oil industry chillers oil well pumping paraffin filter press rotary kilns	M † M M	Slab pushers	M
		Hoists heavy duty medium duty skip hoist	H M M	Stokers	U	Steering gear	†
		Laundry washers reversing	M	Sugar industry cane knives crushers mills	M M M	Textile industry batchers calenders cards dry cans dryers dyeing machinery knitting machines looms mangles nappers pads range drives slashers soapers spinners tenter frames washers winders	M M M M M M † M M M M M M M M
		Laundry tumblers	M	Windlass	†		
		Line shafts driving processing equipment light other line shafts	M U U				
		Lumber industry barkers-hydraulic- mechanical burner conveyor chain saw and drag saw chain transfer craneway transfer de-barking drum edger feed gang feed green chain live rolls log deck	M M M H H H H M M M H H H				
Driven Machine	type of load						
Agitators pure liquids liquids and solids liquids-variable density	U M M						
Blowers centrifugal lobe vane	U M U						
Brewing and distilling bottling machinery brew kettles-continuous duty cookers-continuous duty mash tubs-continuous duty scale hopper-frequent starts	M M M M M						
Can filling machines	M						
Cane knives	M						
Car dumpers	H						
Car pullers	M						
Clarifiers	U						
Classifiers	M						
Clay working machinery brick press briquette machine clay working machinery pug mill	H H M M						
Compressors centrifugal lobe reciprocating multi-cylinder single cylinder	U M M H						
Conveyors-uniformly loaded or fed apron assembly belt bucket chain flight oven screw	U U U U U U U						
Conveyors-heavy duty not uniformly fed apron assembly belt bucket chain flight live roll oven reciprocating screw shaker	M M M M M M † M H M H						

SERIES F

SELECTION PROCEDURE FOR MOTORISED UNITS

EXAMPLE APPLICATION DETAILS

Absorbed power of driven machine = 0.7 kW
 Output speed of gearbox or input speed of machine = 63 rev/min
 Application = Uniformly loaded belt conveyor
 Duration of service (hours per day) = 24hrs
 Mounting position = 1
 Ambient temperature = 20°C
 Running time (%) = 100%

1 DETERMINE MECHANICAL SERVICE FACTOR (Fm)

Refer to Load Classification by Application, table 3, page 4

Application = Uniformly loaded belt conveyor

Conveyors-uniformly loaded or fed

apron	U	U = Uniform load
assembly	U	
belt	U	
bucket	U	
chain	U	

Refer to mechanical service factor (Fm), table 1, page 3

Duration of service (hours per day) = 24hrs

Prime mover	Duration of service-hrs per day	Load classification-drive	
		Uniform	Moderate
Electric motor, steam turbine or hydraulic motor	Under 3	0.80	1.00
	3 to 10	1.00	1.25
	Over 10	1.25	1.50

Therefore mechanical service factor (Fm) = 1.25

If the unit is subject to frequent start/stops Fm must be multiplied by factor Fs (see table 2 page 3)

2 DETERMINE REQUIRED OUTPUT TORQUE AT GEARBOX OUTPUTSHAFT

$$\text{Absorbed output torque} = \frac{\text{Absorbed power} \times 9550}{\text{Gearbox output speed}}$$

$$\frac{0.7 \times 9550}{63} = 106 \text{ Nm}$$

3 SELECT GEARED MOTOR

Refer to selection table one motor size larger than absorbed power.
 Absorbed power = 0.7 kW, therefore refer to 0.75 kW selection table.

Always select from 4 POLE selection table in the first instance as this offers a more economical solution.

Required output speed of gearbox = 63 rev/min

0.75 kW	N2 R/MIN	i	M2 Nm	Fm	N	UNIT DESIGNATION	Kg	Motor Frame Size
	Output Speed	Ratio	Output Torque	Service Factor	Overhung Load	Column Entry <input type="text"/> 1 Through <input type="text"/> 20 Spaces to be filled when entering order	Weight of Base Mount Unit	
4 POLE	72	19.46	95	3.72	4921	F 0 3 2 2 2 0 . . M 7 5 A - -	29.5	80A
	65	21.59	106	3.41	5037	2 2 .		
	57	24.53	120	3.06	5165	2 5 .		
	51	27.86	137	2.74	5302	2 8 .		
	46	30.68	151	2.48	5394	3 2 .		
	40	35.30	173	2.26	5518	3 6 .		
	37	38.37	188	1.97	5586	4 0 .		
	31	46.07	225	1.74	5718	5 0 .		
	26	55.28	271	1.43	5814	5 6 .		

4 CHECK OUTPUT TORQUE

Output torque (M2) of selected unit must be equal or more than required output torque at gearbox outputshaft.

Required output torque at gearbox outputshaft = 106 Nm

0.75 kW	N2 R/MIN	i	M2 Nm	Fm	N	UNIT DESIGNATION	Kg	Motor Frame Size
	Output Speed	Ratio	Output Torque	Service Factor	Overhung Load	Column Entry <input type="text"/> 1 Through <input type="text"/> 20 Spaces to be filled when entering order	Weight of Base Mount Unit	
4 POLE	72	19.46	95	3.72	4921	F 0 3 2 2 2 0 . . M 7 5 A - -	29.5	80A
	65	21.59	106	3.41	5037	2 2 .		
	57	24.53	120	3.06	5165	2 5 .		
	51	27.86	137	2.74	5302	2 8 .		
	46	30.68	151	2.48	5394	3 2 .		
	40	35.30	173	2.26	5518	3 6 .		
	37	38.37	188	1.97	5586	4 0 .		
	31	46.07	225	1.74	5718	5 0 .		
	26	55.28	271	1.43	5814	5 6 .		

Selected unit's output torque (M2) = 106 Nm, therefore unit is acceptable

Go to point 5

SERIES F

SELECTION PROCEDURE FOR MOTORISED UNITS

5 CHECK SERVICE FACTOR

Service factor (Fm) of selected unit must be equal or more than required service factor.

Required service factor of gearbox = 1.25

0.75 kW	N2 R/MIN	i	M2 Nm	Fm	N	UNIT DESIGNATION	Kg	
	Output Speed	Ratio	Output Torque	Service Factor	Overhung Load	Column Entry <input type="text" value="1"/> Through <input type="text" value="20"/> Spaces to be filled when entering order	Weight of Base Mount Unit	Motor Frame Size
4 POLE	72	19.46	95	3.72	4921	F 0 3 2 2 2 0 . . M 7 5 A - -	29.5	80A
	65	21.59	106	3.41	5037	2 2 .		
	57	24.53	120	3.06	5165	2 5 .		
	51	27.86	137	2.74	5302	2 8 .		
	46	30.68	151	2.48	5394	3 2 .		
	40	35.30	173	2.26	5518	3 6 .		
	37	38.37	188	1.97	5586	4 0 .		
	31	46.07	225	1.74	5718	5 0 .		
	26	55.28	271	1.43	5814	5 6 .		

Selected unit's service factor (Fm) = 3.41, therefore unit is acceptable.

Alternatively a F04 unit could be selected which has a larger diameter output bore

0.75 kW	N2 R/MIN	i	M2 Nm	Fm	N	UNIT DESIGNATION	Kg	
	Output Speed	Ratio	Output Torque	Service Factor	Overhung Load	Column Entry <input type="text" value="1"/> Through <input type="text" value="20"/> Spaces to be filled when entering order	Weight of Base Mount Unit	Motor Frame Size
4 POLE	72	19.46	95	3.72	4921	F 0 4 2 2 2 0 . . M 7 5 A - -	29.5	80A
	65	21.59	106	3.41	5037	2 2 .		
	57	24.53	120	3.06	5165	2 5 .		
	51	27.86	137	2.74	5302	2 8 .		
	46	30.68	151	2.48	5394	3 2 .		
	40	35.30	173	2.26	5518	3 6 .		
	37	38.37	188	1.97	5586	4 0 .		
	31	46.07	225	1.74	5718	5 0 .		
	26	55.28	271	1.43	5814	5 6 .		

Selected unit's service factor (Fm) = 3.41, therefore unit is acceptable.

6 CHECK OVERHUNG LOADS

If sprocket, gear, etc is mounted on the outputshaft then refer to Overhung Loads Procedure, and compare with allowable overhung load (N) of selected unit

Allowable overhung load (N) must be equal or more than calculated overhung load (P)

0.75 kW	N2 R/MIN	i	M2 Nm	Fm	N	UNIT DESIGNATION	Kg	
	Output Speed	Ratio	Output Torque	Service Factor	Overhung Load	Column Entry <input type="text" value="1"/> Through <input type="text" value="20"/> Spaces to be filled when entering order	Weight of Base Mount Unit	Motor Frame Size
4 POLE	72	19.46	95	3.72	4921	F 0 3 2 2 2 0 . . M 7 5 A - -	29.5	80A
	65	21.59	106	3.41	5037	2 2 .		
	57	24.53	120	3.06	5165	2 5 .		
	51	27.86	137	2.74	5302	2 8 .		
	46	30.68	151	2.48	5394	3 2 .		
	40	35.30	173	2.26	5518	3 6 .		
	37	38.37	188	1.97	5586	4 0 .		
	31	46.07	225	1.74	5718	5 0 .		
	26	55.28	271	1.43	5814	5 6 .		

NOTE: If any of the following conditions occur then consult Application Engineering

- a) Mass acceleration factor > 10
- b) Ambient temperature is above 40°C

SERIES F

OUTPUT OPTIONS

OUTPUT BORE OPTIONS, COLUMN 11 ENTRY

Column 11 Entry

Standard / Inch Hollow Shaft

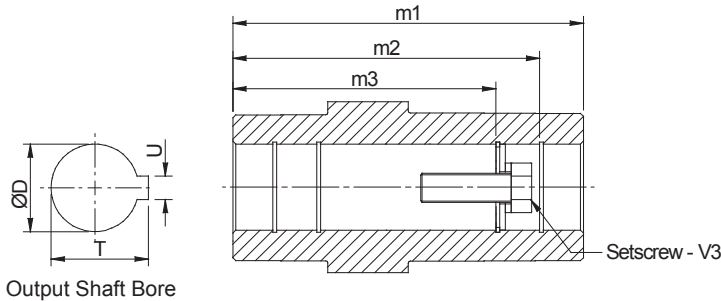

Standard Hollow Shaft

H

Standard Kibo Shaft *

(* entry depends on shaft diameter see page 118 - 119)

Inch Hollow Shaft

A

Inch Taper Release †

†

(† Consult Application Engineering)

UNIT SIZE	TYPE OF BORE	COL 11 ENTRY	DIMENSIONS						
			Ø D	m1	m2	m3	T	U	v3
F02	Standard	H	25.021 / 25.000	117.5	105	89	28.5	8	M10x50
	Inch	A	1.001" / 1.000"	4.63"	4.13"	3.5"	1.11"	0.250"	3/8"UNFx2"
F03	Standard	H	30.025 / 30.000	156.5	122	105	33.5	8	M10x50
	Inch	A	1.251" / 1.250"	6.16"	4.8"	4.13"	1.37"	0.250"	3/8"UNFx2"
F04	Standard	H	35.021 / 35.000	156.5	132	122	38.5	10	M12x55
	Inch	A	1.376" / 1.375"	6.16"	5.20"	4.80"	1.53"	0.313"	1/2"UNFx2.25"
F05	Standard	H	40.025 / 40.000	179	174	142	43.5	12	M16x70
	Inch	A	1.501" / 1.500"	7.05"	6.85"	5.59"	1.67"	0.375"	5/8"UNFx2.75"
F06	Standard	H	40.025 / 40.000	205	174	156	43.5	12	M16x70
	Inch	A	1.501" / 1.500"	8.07"	6.85"	6.14"	1.67"	0.375"	5/8"UNFx2.75"
F07	Standard	H	50.025 / 50.000	233.5	198	183	54	14	M16x70
	Inch	A	2.001" / 2.000"	9.19"	7.80"	7.20"	2.23"	0.500"	5/8"UNFx2.75"
F08	Standard	H	60.030 / 60.000	270	230	210	64.5	18	M20x80
	Inch	A	2.376" / 2.375"	10.63"	9.06"	8.27"	2.66"	0.625"	3/4"UNFx3.25"
F09	Standard	H	70.030 / 70.000	330	270	-	75	20	M20x80
	Inch	A	2.751" / 2.750"	12.99"	10.63"	-	3.04"	0.625"	3/4"UNFx3.25"
F10	Standard	H	80.030 / 80.000	370	313	-	85.5	22	M20x80
	Inch	A	3.251" / 3.250"	14.57"	12.32"	-	3.59"	0.750"	3/4"UNFx3.25"
F11	Standard	H	90.035 / 90.000	350	-	-	95.4	25	-
	Inch	-	-	-	-	-	-	-	-
F12	Standard	H	100.035 / 100.000	410	-	-	106.4	28	-
	Inch	-	-	-	-	-	-	-	-

SERIES F

OUTPUT OPTIONS

OUTPUT SHAFT OPTIONS COLUMN 11 ENTRY

Column 11 Entry

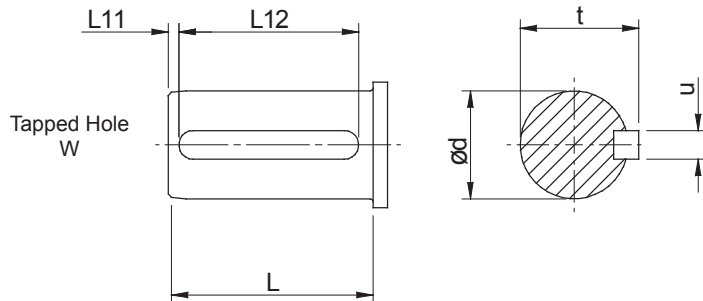

Standard Single Extension C

Inch Single Extension N

UNIT SIZE	TYPE OF BORE	COL 11 ENTRY	DIMENSIONS						
			Ø D	L	L11	L12	t	u	w
F02	Standard	C	-	-	-	-	-	-	-
	Inch	N	-	-	-	-	-	-	-
F03	Standard	C	25.015 / 25.002	47	3	40	28	8	M10x22
	Inch	N	1.0000" / 0.9995"	1.85"	*	1.57"	1.11"	0.250"	3/8"UNFx 0.75"
F04	Standard	C	30.015 / 30.002	56	3	50	33	8	M12x28
	Inch	N	1.2500" / 1.2495"	2.20"	*	2.00"	1.36"	0.250"	1/2"UNF x 1.13"
F05	Standard	C	35.018" / 35.002"	66	3	60	38	10	M16x36
	Inch	N	1.3750" / 1.3745"	2.60"	*	2.38"	1.51"	0.3125"	5/8"UNFx 1.5"
F06	Standard	C	40.018 / 40.002	76	3	70	43	12	M16x36
	Inch	N	1.625" / 1.624"	3.00"	*	2.38"	1.78"	0.375"	5/8"UNFx 1.5"
F07	Standard	C	50.018 / 50.002	95	3	80	53.5	14	M16x36
	Inch	N	2.002" / 1.999"	3.74"	*	2.75"	2.23"	0.500"	5/8"UNFx 1.5"
F08	Standard	C	60.030 / 60.011	114	3	100	64	18	M20x42
	Inch	N	2.375" / 2.374"	4.49"	*	3.69"	2.65	.625"	3/4"UNFx 1.65"
F09	Standard	C	70.030 / 70.011	135	3	110	74.5	20	M20x42
	Inch	N	2.875" / 2.874"	5.32"	*	4.63"	3.20"	0.750"	3/4"UNFx 1.65"
F10	Standard	C	90.035 / 90.013	172	5	140	95	25	M20x42
	Inch	N	3.625" / 3.624"	6.77"	*	5.94"	4.01"	0.875"	3/4"UNFx 1.65"
F11	Standard	C	90.025 / 90.003	170	14	141	95	25	M20x42
	Inch	-	-	-	-	-	-	-	-
F12	Standard	C	110.025 / 110.003	210	25	160	116	28	M24x55
	Inch	-	-	-	-	-	-	-	-

* - Inch Shaft has an open ended keyway, therefore no "L11" dimensions are required

SERIES F

MOTOR ADAPTERS

DOUBLE REDUCTION UNITS

IEC Flanges B14 Column 12 entry for units type G (Column 10)

MOTOR / FRAME FLANGE	UNIT SIZE, NUMBER OF REDUCTIONS, REVISION NUMBER											
	RATIO COVERAGE		F0222		F0322 F0422		F0522		F0622		F0722	
	6.3 - 14.	16. - 90.	7.1 - 25.	28. - 100	5.0 14.	16. - 71.	7.1 - 20.	22. - 100	7.1 - 16.	20. - 100		
71	*H	*H	-	H	-	-	-	-	-	-	-	
80	*B	*K	B	K	-	G	-	G	-	G		
90	*D	*R	D	R	Z	J	Z	J	-	J		
100	*E	*S	E	S	B	L	B	L	B	L		
112	*E	*S	E	S	B	L	B	L	B	L		
132	-	-	-	-	-	-	-	-	D	N		

Motor codes marked with * are not suitable for use with Kibo Bushing



Limited Availability / Non Preferred

IEC Flanges B5 Column 12 entry for units type G (Column 10)

MOTOR / FRAME FLANGE	UNIT SIZE, NUMBER OF REDUCTIONS, REVISION NUMBER																					
	RATIO COVERAGE		F0222		F0322 F0422		F0522		F0622		F0722		F0822		F0921		F1021		F1121		F1221	
	6.3 - 14.	16. - 90.	7.1 - 25.	28. - 100	5.0 14.	16. - 71.	7.1 - 20.	22. - 100	7.1 - 16.	20. - 100	7.1 - 25.	28. 100	5.0 - 25.	28. - 100	5.0 - 25.	28. - 100	5.0 - 63.	5.0 - 63.				
63	*F	*F	-	F	-	V	-	V	-	-	-	-	-	-	-	-	-	-	-	-	-	-
71	*G	*G	-	G	-	D	-	D	-	-	-	-	-	-	-	-	-	-	-	-	-	-
80	*A	*J	*A	*J	W	F	W	F	-	F	-	D	-	E	-	-	-	-	-	-	-	-
90	*C	*Q	*C	*Q	Y	H	Y	H	-	H	-	E	-	F	-	-	-	-	-	-	-	-
100	-	-	-	-	A	K	A	K	A	K	A	F	-	G	-	E	-	-	-	-	-	-
112	-	-	-	-	A	K	A	K	A	K	A	F	-	G	-	E	-	-	-	-	-	-
132	-	-	-	-	N	P	N	P	C	M	B	G	-	H	-	F	-	-	-	-	-	-
160	-	-	-	-	-	-	-	-	-	-	E	-	C	H	A	J	A	G	B	A	-	-
180	-	-	-	-	-	-	-	-	-	-	-	-	-	B	K	B	H	C	B	-	-	-
200	-	-	-	-	-	-	-	-	-	-	-	-	-	C	-	C	-	D	C	-	-	-
225	-	-	-	-	-	-	-	-	-	-	-	-	-	D	-	D	-	E	D	-	-	-
250	-	-	-	-	-	-	-	-	-	-	-	-	-	-	-	-	-	F	E	-	-	-
280	-	-	-	-	-	-	-	-	-	-	-	-	-	-	-	-	-	-	-	-	-	F

NEMA Flanges C face Column 12 entry for units type G (Column 10)

MOTOR / FRAME FLANGE	UNIT SIZE, NUMBER OF REDUCTIONS, REVISION NUMBER																	
	RATIO COVERAGE		F0222		F0322 F0422		F0522		F0622		F0722		F0822		F0921		F1021	
	6.3 - 14.	16. - 90.	7.1 - 25.	28. - 100	5.0 14.	16. - 71.	7.1 - 20.	22. - 100	7.1 - 16.	20. - 100	7.1 - 25.	28. 100	5.0 - 25.	28. - 100	5.0 - 25.	28. - 100		
56C	*T	*U	T	U	-	Q	-	Q	-	Q	-	M	-	-	-	-		
143/145TC	*U	*W	U	W	-	R	-	R	-	R	-	N	-	-	-	-		
182/184TC	*X	-	*X	-	S	T	S	T	S	T	J	P	-	S	-	P		
213/215TC	-	-	-	-	U	-	U	-	U	V	K	Q	-	T	-	Q		
254/256TC	-	-	-	-	-	-	-	-	W	-	L	U	P	U	L	R		
284/286TC	-	-	-	-	-	-	-	-	-	-	-	Q	V	M	S			
324/326TC	-	-	-	-	-	-	-	-	-	-	-	R	W	N	T			

SERIES F

MOTOR ADAPTERS

TRIPLE REDUCTION UNITS

IEC Flanges B14 Column 12 entry for units type G (Column 10)

MOTOR / FRAME FLANGE	UNIT SIZE, NUMBER OF REDUCTIONS, REVISION NUMBER						
		F0232	F0332 F0432	F0532	F0632	F0732	F0832
	RATIO COVERAGE	90. - 315	100 - 360	80. - 280	100 - 360	100 - 360	100 - 360
71	COLUMN 12 ENTRY	*H	H	H	H	-	-
80		*K	K	K	K	G	G
90		*R	R	R	R	J	J
100		-	-	-	-	-	L
112		-	-	-	-	-	L
132		-	-	-	-	-	N

Motor codes marked with * are not suitable for use with Kibo Bushing



Limited Availability / Non Preferred

IEC Flanges B5 Column 12 entry for units type G (Column 10)

MOTOR / FRAME FLANGE	UNIT SIZE, NUMBER OF REDUCTIONS, REVISION NUMBER										
		F0232	F0332 F0432	F0532	F0632	F0732	F0832	F0931	F1031	F1131	F1231
	RATIO COVERAGE	90. - 315	100 - 360	80. - 280	100 - 360	100 - 360	100 - 360	100 - 360	100 - 360	45 - 315	45 - 315
63	COLUMN 12 ENTRY	*F	F	F	F	-	-	-	-	-	-
71		*G	G	G	G	-	-	-	-	-	-
80		*J	J	J	J	F	F	-	E	-	-
90		Q	Q	Q	Q	H	H	M	F	-	-
100		-	-	-	-	K	K	N	G	A	-
112		-	-	-	-	K	K	N	G	B	-
132		-	-	-	-	-	M	-	H	C	A
160		-	-	-	-	-	-	-	J	D	B
180		-	-	-	-	-	-	-	K	E	C
200		-	-	-	-	-	-	-	-	-	D
225		-	-	-	-	-	-	-	-	-	E

NEMA Flanges C face Column 12 entry for units type A (Column 10)

MOTOR / FRAME FLANGE	UNIT SIZE, NUMBER OF REDUCTIONS, REVISION NUMBER								
		F0232	F0332 F0432	F0532	F0632	F0732	F0832	F0931	F1031
	RATIO COVERAGE	90. - 315	100 - 360	80. - 280	100 - 360	100 - 360	100 - 360	100 - 360	100 - 360
56C	COLUMN 12 ENTRY	*U	U	U	U	Q	Q	X	-
143/145TC		*W	W	W	W	R	R	Y	-
182/184TC		-	-	-	-	T	T	Z	S
213/215TC		-	-	-	-	-	V	-	T
254/256TC		-	-	-	-	-	-	-	U
284/286TC		-	-	-	-	-	-	-	V
324/326TC		-	-	-	-	-	-	-	W

SERIES F

MOTOR ADAPTERS

QUADRUPLE REDUCTION UNITS

IEC Flanges B14 Column 12 entry for units type G (Column 10)

MOTOR / FRAME FLANGE	UNIT SIZE, NUMBER OF REDUCTIONS, REVISION NUMBER							
		F0342 F0442	F0542	F0642	F0742	F0842	F0941	F1041
	RATIO COVERAGE	400 - 50C	320 - 40C	400 - 50C	400 - 56C	400 - 56C	400 - 56C	400 - 56C
71	COLUMN 12 ENTRY	H	H	H	H	-	-	-
80		K	K	K	K	G	G	G
90		R	R	R	R	J	J	J
100		-	-	-	-	L	L	L
112		-	-	-	-	L	L	L
132		-	-	-	-	-	-	N

 Limited Availability / Non Preferred

IEC Flanges B5 Column 12 entry for units type G (Column 10)

MOTOR / FRAME FLANGE	UNIT SIZE, NUMBER OF REDUCTIONS, REVISION NUMBER							
		F0342 F0442	F0542	F0642	F0742	F0842	F0941	F1041
	RATIO COVERAGE	400 - 50C	320 - 40C	400 - 50C	400 - 56C	400 - 56C	400 - 56C	400 - 56C
63	COLUMN 12 ENTRY	F	F	F	F	V	V	-
71		G	G	G	G	D	D	-
80		J	J	J	J	F	F	F
90		Q	Q	Q	Q	H	H	H
100		-	-	-	-	K	K	K
112		-	-	-	-	K	K	K
132		-	-	-	-	P	P	M

NEMA Flanges C face Column 12 entry for units type A (Column 10)

MOTOR / FRAME FLANGE	UNIT SIZE, NUMBER OF REDUCTIONS, REVISION NUMBER							
		F0342 F0442	F0542	F0642	F0742	F0842	F0941	F1041
	RATIO COVERAGE	400 - 50C	320 - 40C	400 - 50C	400 - 56C	400 - 56C	400 - 56C	400 - 56C
56C	COLUMN 12 ENTRY	U	U	U	U	Q	Q	Q
143/145TC		W	W	W	W	R	R	R
182/184TC		-	-	-	-	T	T	T
213/215TC		-	-	-	-	-	-	V

Gear units 02, 03, 04, 05, 06 & 07 will be supplied filled with a quantity of EP mineral oil (Grade 6E) appropriate to the intended mounting position. However if, as requested, the unit is supplied without lubricant then the oil quantity required is obtained from Table 2. Gear units 08, 09, 10 & 12 are supplied without lubricant. Recommended lubricants are listed in the Approved Lubricant scheme booklet.

TEMPERATURE LIMITATIONS

The standard lubricant is suitable for operation in ambient temperatures of 0° to 35°C, outside of this consult Table 1 or Application Engineers.

TABLE 1 OIL GRADES

LUBRICANT	AMBIENT TEMPERATURE RANGE		
	-5°C to 20°C (type E) -30°C to 20°C (type H)	0°C to 35°C	
EP Mineral Oil (type E)	5E (VG 220)	6E (VG 320)	7E (VG 460) 20°C to 50°C
Polyalphaolefin based Synthetic (type H)	5H (VG 220)	5H (VG 220)	6H (VG 320)

TABLE 2 Lubrication Quantity (Litres)

DOUBLE REDUCTION												
Unit Size	F0222	F0322	F0422	F0522	F0622	F0722	F0822	F0921	F1021	F1121	F1221	
MOUNTING POSITION	1	0.8	1.3	1.3	2.1	3.5	6.3	10.7	19	34	28	47
	2	0.4	0.8	0.8	1.4	2.3	3.5	7.1	13	22	17	27
	3	0.4	1.1	1.1	1.4	2.3	3.4	8.8	17	28	22	36
	4	0.5	0.8	0.8	1.8	3.0	5.0	4.7	15	27	24	40
	5	1.1	1.2	1.2	2.8	4.5	8.0	9.7	24	43	34	56
	6	1.3	2.0	2.0	3.2	5.2	9.0	17.2	25	43	30	50

TRIPLE REDUCTION												
Unit Size	F0232	F0332	F0432	F0532	F0632	F0732	F0832	F0931	F1031	F1131	F1231	
MOUNTING POSITION	1	0.8	1.2	1.3	2.1	3.5	6.3	10.4	19	34	27	45
	2	0.4	0.8	0.8	1.4	2.3	3.5	7.3	15	24	16	25
	3	0.4	1.1	1.1	1.4	2.3	3.4	9.2	17	28	21	34
	4	0.5	0.8	0.8	1.8	3.0	5.0	5.3	16	27	23	38
	5	1.1	1.2	1.2	2.8	4.5	8.0	9.7	24	43	33	53
	6	1.3	2.0	2.0	3.2	5.2	9.0	17.4	25	43	29	48

QUADRUPLE REDUCTION											
Unit Size	F0342		F0442		F0542		F0642		F0742		
	Primary	Secondary	Primary	Secondary	Primary	Secondary	Primary	Secondary	Primary	Secondary	
	M0122	F0322	M0122	F0422	M0322	F0522	M0322	F0622	M0322	F0722	
MOUNTING POSITION	1	0.5	1.3	0.5	1.3	0.8	2.1	0.8	3.5	0.8	6.3
	2	0.5	0.8	0.5	0.8	0.8	1.4	0.8	2.3	0.8	3.5
	3	0.5	1.1	0.5	1.1	0.8	1.4	0.8	2.3	0.8	3.4
	4	0.5	0.8	0.5	0.8	0.8	1.8	0.8	3.0	0.8	5.0
	5	0.7	1.2	0.7	1.2	1.1	2.8	1.1	4.5	1.1	8.0
	6	1.0	2.0	1.0	2.0	1.4	3.2	1.4	5.2	1.4	9.0

QUADRUPLE REDUCTION..CONT							
Unit Size	F0842		F0941		F1041		
	Primary	Secondary	Primary	Secondary	Primary	Secondary	
	M0522	F0822	M0522	F0921	M0722	F1021	
MOUNTING POSITION	1	1.5	10.7	1.5	19.0	2.6	34.0
	2	1.5	7.1	1.5	13.0	2.6	22.0
	3	1.5	8.8	1.5	17.0	2.6	28.0
	4	1.5	4.7	1.5	15.0	2.6	27.0
	5	2.0	9.7	2.0	24.0	3.2	43.0
	6	2.6	17.2	2.6	25.0	4.7	43.0

NOTE: Primary units filled with Grade 6E lubricant suitable for all ambient temperatures between 0°C and 35°C

SERIES F

MOUNTING POSITIONS

Mounting Positions

COLUMN 13 ENTRY

Enter for units with no oil fill

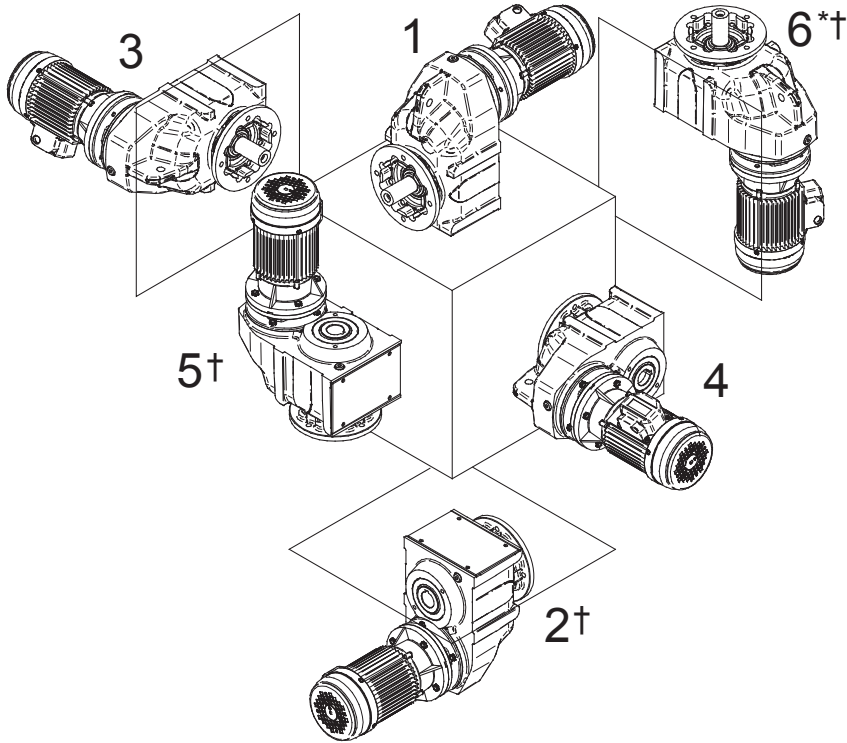

* Mounting Position 6 is not recommended for Geared Motors - Consult Application Engineering
 † Gear Units selected for use in mounting positions 2, 5 and 6 should only be used with overall ratios greater or equal to those shown in the table below

Unit Size	Input Speed (rpm)			
	< 1000	< 1500	< 1800	> 1800
F02 - F07	All	All	All	
F0822	All	9.0	9.0	
F0921	8.0	11.0	12.0	
F1021	11.0	16.0	18.0	
F1121	Consult Application Engineering			
F1221				

MOUNTING POSITIONS - SHOWN AS MOTORIZED - APPLIES ALSO FOR REDUCERS

COLUMN 14 ENTRY

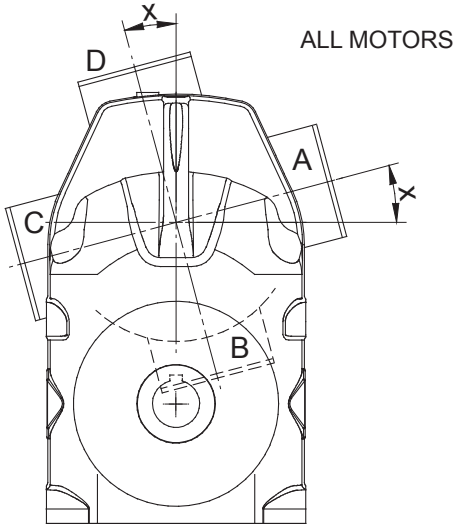

Column 14 Entry	Angle X				
	F02	F03	F04	F05	F06
A	15°	23°	23°	9.5°	16.5°
B	105°	113°	113°	99.5°	106.5°
C	195°	203°	203°	189.5°	196.5°
D	285°	293°	293°	279.5°	286.5°
-	Reducer or no motor fitted				

Column 14 Entry	Angle X	
	F07	F08, F09, F10, F11, F12
A	28°	0°
B	118°	90°
C	208°	180°
D	298°	270°
-	Reducer or no motor fitted	

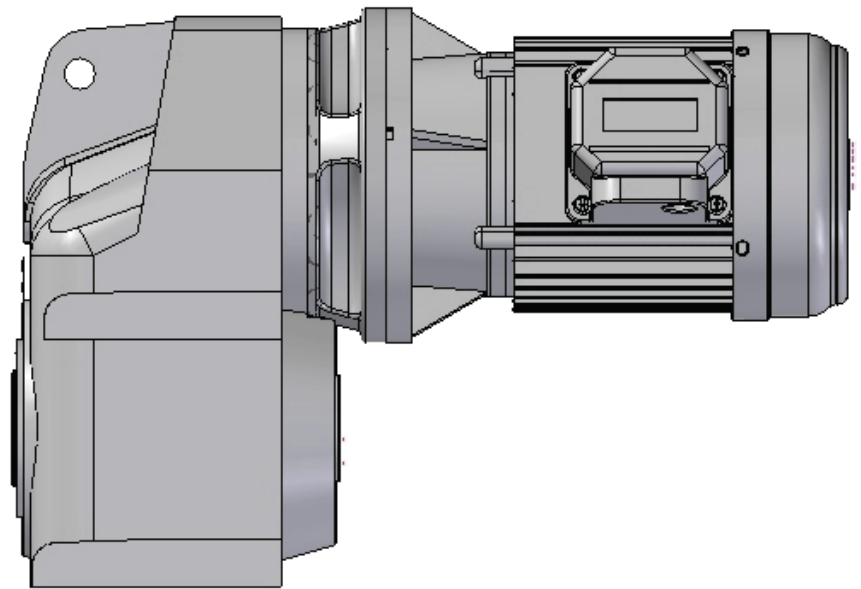

**MOTORISED
SERIES F**

SERIES F

MOTOR PERFORMANCE DATA

TEFC squirrel cage three phase motors
4 poles = 1500 rpm 400V, 50Hz, S1 IP55, Class F

Output Power Kw	Frame Size	Speed (RPM)	I (A)	Ist	Tst	J
				I	T	(Kgm2)
0.12	63	1360	0.6	2.6	2.5	0.000
0.18	63	1370	0.72	3	2.2	0.000
0.25	71	1400	0.83	3.5	2.2	0.001
0.37	71	1410	1.12	4	2.2	0.001
0.55	80A	1420	1.45	4	2.2	0.002
0.75	80A	1420	1.8	4.5	2.2	0.002
1.1	90S	1410	2.59	5	2.2	0.003
1.5	90L	1420	3.45	5	2.4	0.004
2.2	100L	1430	4.8	5.5	2.4	0.007
3	100L	1430	6.48	5.5	2.5	0.008
4	100L	1420	8.73	5.5	2.5	0.009
4	112M	1435	8.6	7	2.9	0.015
5.5	112M	1425	11.4	7.1	2.8	0.018
5.5	132S	1450	11.1	7.3	2.2	0.031
7.5	132M	1450	14.8	7.9	2.5	0.038
9	132M	1450	18	8.1	2.8	0.043
11	132M	1450	21	8.3	3	0.048
11	160M	1460	21.5	6.7	2.9	0.067
15	160L	1455	28.5	6.8	2	0.091
18.5	160L	1450	36	6.9	2.9	0.102
18.5	180M	1470	35	6.7	3.1	0.161
22	180L	1470	41	6.8	2.9	0.191
30	180L	1465	56	6.9	3.2	0.225
30	200L	1475	56	6.7	2.6	0.29
37	200L	1475	68	7.8	3.6	0.34
37	225S	1480	68	6.6	2.4	0.37
45	225M	1480	83	6.7	2.7	0.42
55	225M	1480	100	7.3	3.1	0.49
55	250M	1480	98	7.5	2.3	0.72
75	250M	1480	132	7	2.4	0.88
75	280S	1483	137	6.8	2.4	1.15
90	280M	1484	163	7.1	2.7	1.4
110	280M	1483	195	7.5	2.7	1.7

High Power Motor (Non Standard)

I = Nominal current
Ist/I = Starting current factor
Tst/T = Starting torque factor
J = Motor moment of inertia

Recalculation Factors

Recalculation factors for current at rated voltages other than 400V, 50 Hz.

Rated voltage at 50Hz and motor wound for	Recalculation factor
220V	1.82
230V	1.74
415V	0,96
500V	0,80
660V	0,61
690V	0,58

TEFC squirrel cage three phase motors
6 poles = 1000 rpm 400V, 50Hz, S1 IP55, Class F

Output Power Kw	Frame Size	Speed (RPM)	I (A)	Ist	Tst	J
				I	T	(Kgm2)
0.12	63	900	0.6	2.1	2.1	0.000
0.18	71	920	0.75	2.5	2	0.001
0.25	71	920	0.92	3	2	0.001
0.37	80A	920	1.25	3.5	2.1	0.002
0.55	80B	930	1.78	3.5	2.1	0.002
0.75	90S	930	2.36	4	1.9	0.003
1.1	90L	930	3.25	4	1.9	0.004
1.5	100L	940	5.8	4.5	1.9	0.009
2.2	112M	940	5.8	4.5	1.9	0.009
2.2	100L	940	5.4	5.6	2.1	0.015
3	112M	935	7.2	5.5	2.4	0.018
3	132S	960	6.9	6.1	2.4	0.031
4	132M	960	8.7	7.1	2.6	0.038
5.5	132M	955	11.9	6.9	2.8	0.045
7.5	160M	970	15.4	6.7	2	0.089
11	160L	970	23	7.1	2.2	0.107
15	180L	970	31	7	2.1	0.217
18.5	180L	965	37.5	6.2	2	0.237
18.5	200L	985	36	7	2.5	0.370
22	200L	980	43	7.2	2.5	0.430
30	200L	980	56	7.5	3.3	0.490
30	225M	985	56	6.6	2.5	0.640
37	225M	985	69	7.7	3.1	0.750
37	250M	985	69	7.3	2.8	1.160
45	250S	985	82	7.3	2.8	1.490
45	280S	990	85	6.6	2.6	1.650

High Power Motor (Non Standard)

I = Nominal current
Ist/I = Starting current factor
Tst/T = Starting torque factor
J = Motor moment of inertia

60 Hz Operation

Motors wound for a certain voltage at 50 Hz can be operated at 60 Hz, without any modifications, subject to the following changes in their data

Motor wound for 50 Hz and	Connected to 60 Hz and	Data at 60 Hz in percentage of values at 50 Hz					
		P kW	n rpm	I A	Ist/I	T Nm	Tst/T
400V	380V	100	120	100	80	83	66
	400V	100	120	98	83	83	70
	415V	105	120	100	88	86	78
	440V	110	120	100	95	91	85
	460V	115	120	100	100	96	95
	480V	120	120	100	105	100	100

MOTOR DETAILS

B14 'C' FACE

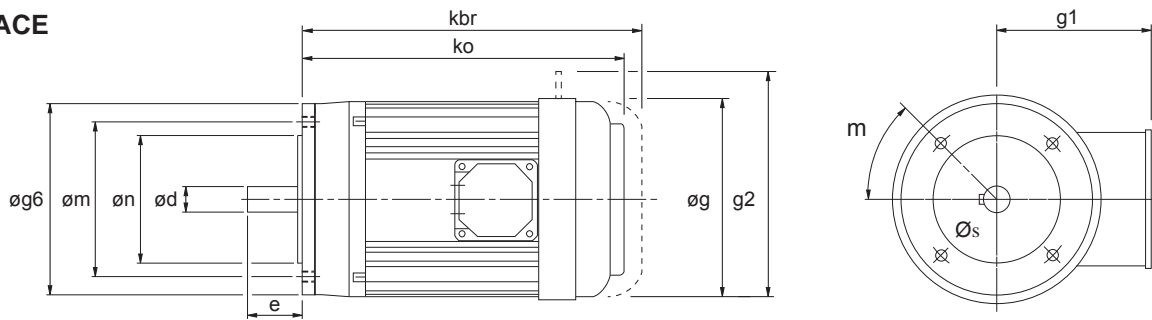

MOTOR FRAME SIZE	Øg6	Øm	Øn	Ød	e	ko*	kbr*	Øg	g1*	m	Øs
71	105	85	70	14	30	221	265	138	102	45°	4 x M6
80A	120	100	80	19	40	239	291	157	125	45°	4 x M6
80B	120	100	80	19	40	248	300	157	125	45°	4 x M6
90S	140	115	95	24	50	260	312	177	133	45°	4 x M8
90L	140	115	95	24	50	275	327	177	133	45°	4 x M8
100L	160	130	110	28	60	310	370	197	144	45°	4 x M8
112M	160	130	110	28	60	325	399	219	155	45°	4 x M8
132S	200	165	130	38	80	392	475	235	172	45°	4 x M10
132M	200	165	130	38	80	412	495	235	172	45°	4 x M10

B5 'D' FACE

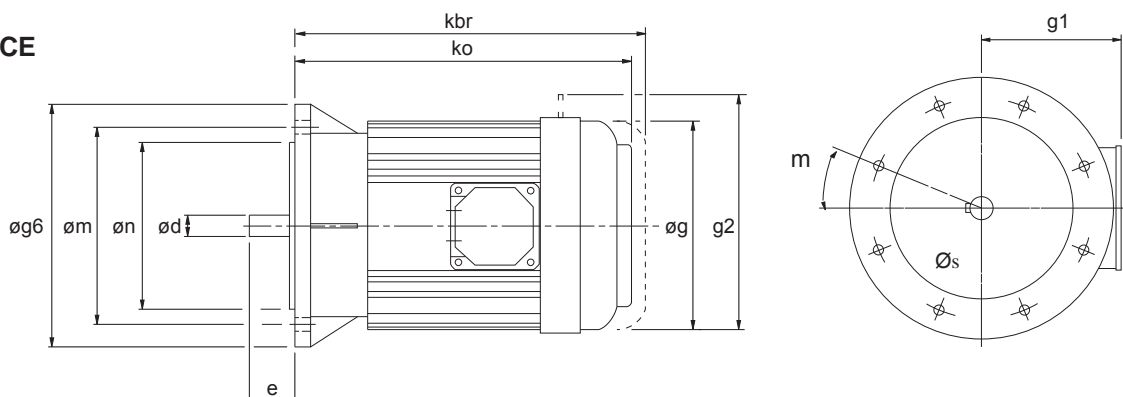

MOTOR FRAME SIZE	Øg6	Øm	Øn	Ød	e	ko*	kbr*	Øg	g1*	m	Øs
63	140	115	95	11	23	218	263	122	96	45°	4 x M8
71	160	130	110	14	30	221	265	138	102	45°	4 x M8
80A	200	165	130	19	40	239	291	157	125	45°	4 x M10
80B	200	165	130	19	40	248	300	157	125	45°	4 x M10
90S	200	165	130	24	50	260	312	177	133	45°	4 x M10
90L	200	165	130	24	50	275	327	177	133	45°	4 x M10
100L	250	215	180	28	60	310	370	197	144	45°	4 x M12
112M	250	215	180	28	60	325	399	219	155	45°	4 x M12
132S	300	265	230	38	80	392	475	235	172	45°	4 x M12
132M	300	265	230	38	80	412	495	235	172	45°	4 x M12
160M	350	300	250	42	110	455	538	273	282	45°	4 x M16
160L	350	300	250	42	110	500	583	273	282	45°	4 x M16
180M	350	300	250	48	110	557	-	382	307	22.5°	4 x M16
180L	350	300	250	48	110	595	-	382	307	22.5°	4 x M16
200L	400	350	300	55	110	658	-	420	372	-	4 x M16
225S	450	400	350	60	140	671	-	458	427	-	8 x M16
225M	450	400	350	60	140	696	-	458	427	-	8 x M16
250M	550	500	450	65	140	771	-	510	490	-	8 x M16
280S	550	500	450	75	140	837	-	576	520	-	8 x M16
280M	550	500	450	75	140	888	-	576	520	-	8 x M16

* Motor lengths for own brand standard motors. These lengths may vary if alternative motor is fitted.

SERIES F

ADDITIONAL MOTOR FEATURES

ADDITIONAL MOTOR FEATURES - COLUMN 19 ENTRY

Column 19 Entry	Brake Motor	Hand Release on Brake	Forced Ventilation/ Constant Blower (TECB)	Thermistors	Special
-					
A	•				
B	•	•			
C			•		
D	•		•		
E	•	•	•		
F				•	
G	•			•	
H	•	•		•	
K			•	•	
L	•		•	•	
M	•	•	•	•	
S					•

Please refer to Application Engineering for details of the following additional motor features

- PGF encoder flange
- Wash down
- Customised brake torque
- Separate brake supply
- Aluminium fan
- Anti Condensation heater
- Bi-metal temperature detectors, Thermostat
- EExEIIT3
- Ex nA II T3
- IP56
- IP65
- Metal fan cover
- Rain cowl
- Separate terminal box

SERIES F

ADDITIONAL GEARBOX FEATURES

ADDITIONAL GEARBOX FEATURES - COLUMN 20 ENTRY

Column 20 Entry	Double Outputshaft Oil Seals **	Oil Level Glass - F10	* Motorised Backstop		Special
			CW Rotation	CCW Rotation	
-					
A	•				
B		•			
C	•	•			
D			•		
E	•		•		
F		•	•		
G	•	•	•		
H				•	
I	•			•	
J		•		•	
K	•	•		•	
L					•

Please refer to Application Engineering for details of the special additional gearbox features for example :-

- Prime paint only
- Wash down
- BISSC compatible
- Special oil (food compatible, bio-degradable, different viscosities etc)

* IEC frame sizes 100 - 200 NEMA frame sizes 182TC - 326TC

** Double output seals are not available for sizes F02 & F05.

SERIES F

EXACT RATIOS

EXACT RATIOS - DOUBLE REDUCTION

Column Entry			F0222	F0322	F0422	F0522	F0622	F0722	F0822	F0921	F1021	F1121	F1221
6	7	8											
4.5			-	-	-	-	-	-	-	-	-	4.53	4.63
5.0			-	-	-	4.841	-	-	-	5.085	5.107	5.16	5
5.6			-	-	-	-	-	-	-	-	-	5.53	5.73
6.3			5.903	-	-	6.806	-	-	-	6.567	6.433	6.3	6.19
7.1			7.974	6.262	6.262	7.628	7.494	6.772	6.959	7.000	7.133	7.2	7.31
8.0			-	-	-	-	-	-	-	7.846	7.758	8.2	7.9
9.0			9.069	8.784	8.784	8.563	8.750	9.380	9.865	8.807	8.812	8.75	9.19
10.			10.27	9.680	9.680	10.87	9.807	10.54	10.96	10.13	9.772	9.97	9.92
11.			-	-	-	12.33	-	-	-	11.35	11.48	11.33	11.55
12.			13.14	10.99	10.99	-	11.009	11.59	12.19	12.68	12.39	12.9	12.48
14.			14.16	13.96	13.96	14.70	13.98	15.13	15.76	14.66	14.46	13.66	13.88
16.			17.88	15.86	15.86	16.93	15.85	17.21	17.70	16.37	15.61	15.56	14.99
18.			-	-	-	19.69	-	-	-	17.58	18.07	17.96	17.77
20.			20.27	19.46	19.46	-	18.90	20.89	20.77	20.04	20.46	20.46	19.19
22.			23.16	21.59	21.59	22.03	21.76	22.98	23.40	22.70	22.76	22.42	22.84
25.			25.77	24.52	24.52	23.48	25.31	26.41	27.24	25.88	21.70	25.54	24.67
28.			28.41	27.86	27.86	27.83	28.32	29.95	30.21	28.41	24.45	28.4	28.92
32.			31.26	30.68	30.68	29.71	30.18	33.03	33.07	31.56	28.46	32.34	31.23
36.			36.63	35.30	35.30	36.87	35.77	37.83	37.41	36.69	31.57	34.96	35.61
40.			43.94	38.37	38.37	43.47	38.19	42.77	42.23	40.76	34.55	39.83	38.46
45.			-	-	-	47.60	-	-	-	44.58	39.09	44.74	43.75
50.			51.22	46.07	46.07	-	47.40	49.59	51.19	49.22	44.13	50.96	47.26
56.			56.91	55.28	55.28	58.34	55.89	59.14	59.69	57.58	53.49	51.85	54.03
63.			68.54	62.29	62.29	65.02	61.20	64.77	65.57	63.56	62.38	59.06	58.36
71.			78.56	72.41	72.41	72.92	75.00	77.72	80.36	67.71	68.52	-	-
80.			-	-	-	-	-	-	-	76.14	83.97	-	-
90.			89.28	82.18	82.18	-	83.59	89.42	87.75	87.44	91.70	-	-
100			-	93.43	93.43	-	93.75	99.36	101.05	98.32	105.60	-	-

SERIES F

EXACT RATIOS

EXACT RATIOS - TRIPLE REDUCTION

Column Entry			F0232	F0332	F0432	F0532	F0632	F0732	F0832	F0931	F1031	F1131	F1231
6	7	8											
45.			-	-	-	-	-	-	-	-	-	45.6	44.96
50.			-	-	-	-	-	-	-	-	-	51.94	48.56
56.			-	-	-	-	-	-	-	-	-	55.67	58.27
63.			-	-	-	-	-	-	-	-	-	63.42	62.94
71.			-	-	-	-	-	-	-	-	-	72.26	72.17
80.			-	-	-	78.8	-	-	-	-	-	82.3	77.95
90.			92.02	-	-	86.8	-	-	-	-	-	90.56	93.43
100			101.5	99.52	99.52	99.86	101.4	108.6	114.2	102.5	102.8	103.15	100.91
112			111.6	109.7	109.7	108.6	111.6	115.7	124.9	113.9	114.2	110.94	115.39
125			130.8	120.7	120.7	130.3	128.4	137.1	141.3	132.3	129.5	126.37	124.63
140			-	-	-	-	-	-	-	147.0	143.9	140.77	139.88
160			156.9	141.5	141.5	156.4	139.6	146.4	159.5	160.8	162.9	160.35	151.08
180			182.9	169.7	169.7	176.2	167.6	181.7	193.4	177.5	187.7	178.07	181.27
200			203.3	197.8	197.8	204.9	201.1	214.2	225.5	207.7	205.2	202.84	195.79
225			244.8	219.8	219.8	232.5	226.6	234.6	247.7	229.3	236.4	225.49	229.54
250			-	-	-	-	-	-	-	244.2	253.9	256.85	247.92
280			280.6	264.7	264.7	264.3	263.4	287.5	303.6	274.6	272.7	277.27	285.33
315			318.8	303.4	303.4	-	298.9	320.4	331.5	315.4	319.8	315.83	308.18
360			-	344.8	344.8	-	339.8	359.4	381.8	354.7	343.6	-	-

EXACT RATIOS - QUAD REDUCTION

Column Entry			F0342	F0442	F0542	F0642	F0742	F0842	F0941	F1041
6	7	8								
320			-	-	314.4	-	-	-	-	-
360			-	-	351.7	-	-	-	-	-
400			410.0	410.0	412.8	404.2	404.1	395.8	395.7	400.7
450			456.1	456.1	444.3	445.1	464.4	460.4	460.2	445.3
500			502.9	502.9	489.3	498.0	534.1	490.0	511.0	489.8
560			577.7	577.7	562.8	571.2	580.7	570.0	594.3	562.9
630			637.0	637.0	611.9	629.0	658.5	637.7	664.9	638.3
700			701.0	701.0	694.2	723.5	726.3	679.7	708.7	704.0
800			821.3	821.3	837.0	786.6	831.8	805.5	839.9	806.2
900			914.9	914.9	931.5	892.4	944.4	909.5	926.7	924.8
10C			997.6	997.6	1026	983	1040	1018	1037	1049
11C			1097.9	1098	1148	1130	1090	1085	1105	1157
12C			1237.1	1237	1180	1238	1196	1191	1177	1325
14C			1449.3	1449	1377	1346	1350	1412	1395	1498
16C			1543.2	1543	1552	1615	1571	1594	1520	1564
18C			1798.9	1799	1848	1770	1770	1890	1802	1792
20C			2026.9	2027	2082	1995	2052	2017	1924	2026
22C			2252.1	2252	2242	2184	2312	2293	2180	2349
25C			2406.9	2407	2421	2539	2454	2503	2387	2523
28C			2758.8	2759	2747	2882	2785	2703	2815	2801
32C			3152.7	3578	3123	3112	3225	3232	3082	3068
36C			3578.4	3578	3481	3532	3660	3628	3656	3681
40C			4101.5	4102	3904	3937	4161	3961	3777	4235
45C			4662.8	4663	-	4415	4679	4415	4210	4550
50C			5299.2	5299	-	5019	5319	4952	4722	4706
56C			-	-	-	-	-	5702	5310	5056

SERIES F

SELECTION TABLES

GEARED MOTORS

0.12 kW

N2 R/MIN	i	M2 Nm	Fm	N	Unit Designation	Kg	
Output Speed	Ratio	Output Torque	Service Factor	Overhung Load	Column Entry [1] Through [20] Spaces to be filled when entering order	Weight of base mount unit	Motor Sizes
237	5.90	4	15.23	1393	F 0 2 2 2 6 . 3 _ M _ _ _ _ . 1 2 A - -	16	63
176	7.97	6	11.88	1553	7 . 1		
154	9.07	7	10.87	1630	9 . 0		
136	10.27	8	10.09	1706	1 0 .		
107	13.14	10	8.91	1862	1 2 .		
99	14.16	11	8.32	1916	1 4 .		
78	17.88	14	7.09	2090	1 6 .		
69	20.27	15	6.87	2185	2 0 .		
60	23.16	18	6.00	2300	2 2 .		
54	25.77	20	5.60	2390	2 5 .		
49	28.41	22	5.32	2476	2 8 .		
45	31.26	24	5.04	2554	3 2 .		
38	36.63	28	4.61	2717	3 6 .		
32	43.94	34	3.79	2893	4 0 .		
27	51.22	40	3.23	3078	5 0 .		
25	56.91	44	2.93	3166	5 6 .		
20	68.54	53	2.43	3434	6 3 .		
18	78.56	61	2.08	3569	7 1 .		
16	89.28	73	1.44	3753	9 0 .		
15	92.02	70	1.84	3860	F 0 2 3 2 9 0 . _ M _ _ _ _ . 1 2 A - -	17	63
14	101.45	78	1.65	3860	1 0 0		
13	111.65	85	1.53	3860	1 1 2		
11	130.81	101	1.32	3860	1 2 5		
8.9	156.90	128	1.07	3860	1 6 0		
7.7	182.90	150	0.94	3860	1 8 0		
6.9	203.30	166	0.87	3860	2 2 5		
15	93.43	73	3.44	7100	F 0 3 2 2 1 0 0 _ M _ _ _ _ . 1 2 A - -	23	63
10	141.47	110	3.74	7100	F 0 3 3 2 1 6 0 _ M _ _ _ _ . 1 2 A - -	24	63
8.2	169.72	132	3.22	7100	1 8 0		
7.1	197.84	153	2.83	7100	2 0 0		
6.4	219.82	170	2.58	7100	2 2 5		
5.3	264.71	205	2.15	7100	2 8 0		
4.6	303.42	235	1.83	7100	3 1 5		
4.1	344.83	268	1.59	7100	3 6 0		
3.4	410.03	334	1.12	7100	F 0 3 4 2 4 0 0 _ M _ _ _ _ . 1 2 A - -	33	63
3.1	456.12	372	1.01	7100	4 5 0		
2.8	502.87	410	0.91	7100	5 0 0		
2.4	577.75	471	0.83	7100	5 6 0		
15	93.43	73	3.44	7100	F 0 4 2 2 1 0 0 _ M _ _ _ _ . 1 2 A - -	23	63
10	141.47	110	3.74	7100	F 0 4 3 2 1 6 0 _ M _ _ _ _ . 1 2 A - -	24	63
8.2	169.72	132	3.22	7100	1 8 0		
7.1	197.84	153	2.83	7100	2 0 0		
6.4	219.82	170	2.58	7100	2 2 5		
5.3	264.71	205	2.15	7100	2 8 0		
4.6	303.42	235	1.83	7100	3 1 5		
4.1	344.83	268	1.59	7100	3 6 0		
3.4	410.03	334	1.12	7100	F 0 4 4 2 0 0 _ M _ _ _ _ . 1 2 A - -	33	63
3.1	456.12	372	1.01	7100	4 5 0		
2.8	502.87	410	0.91	7100	5 0 0		
2.4	577.75	471	0.83	7100	5 6 0		
5.3	264.35	205	3.17	9200	F 0 5 3 2 2 8 0 _ M _ _ _ _ . 1 2 A - -	32	63
4.5	314.39	244	2.67	9200	F 0 5 4 2 3 2 0 _ M _ _ _ _ . 1 2 A - -	44	63
4.0	351.75	273	2.49	9200	3 6 0		
3.4	412.85	320	2.12	9200	4 0 0		
3.2	444.31	344	1.97	9200	4 5 0		
2.9	489.28	379	1.79	9200	5 0 0		
2.5	562.80	436	1.56	9200	5 6 0		
2.3	611.86	474	1.43	9200	6 3 0		
2.0	694.17	538	1.26	9200	7 0 0		
1.7	837.03	649	1.05	9200	8 0 0		
1.5	931.53	722	0.94	9200	9 0 0		
1.4	1025.81	795	0.85	9200	1 0 C		
4.1	339.84	264	3.17	11300	F 0 6 3 2 3 6 0 _ M _ _ _ _ . 1 2 A - -	47	63
3.5	404.18	313	2.68	11300	F 0 6 4 2 4 0 0 _ M _ _ _ _ . 1 2 A - -	58	63
3.2	445.09	345	2.43	11300	4 5 0		
2.8	497.98	386	2.28	11300	5 0 0		
2.5	571.21	443	2.02	11300	5 6 0		
2.2	629.02	487	1.83	11300	6 3 0		
1.9	723.53	561	1.59	11300	7 0 0		
1.8	786.61	610	1.47	11300	8 0 0		
1.6	892.42	692	1.31	11300	9 0 0		
1.4	982.74	762	1.19	11300	1 0 C		
1.2	1130.40	876	1.04	11300	1 1 C		
1.1	1237.77	959	0.95	11300	1 2 C		
1.0	1345.68	1043	0.87	11300	1 4 C		

NOTE
Other output speeds are available using 2 and 8 pole motors - Please contact our Application Engineers

SERIES F

SELECTION TABLES

GEARED MOTORS

0.12 kW

N2 R/MIN	i	M2 Nm	Fm	N	Unit Designation	Kg	Motor Sizes
Output Speed	Ratio	Output Torque	Service Factor	Overhung Load	Column Entry [1] Through [20] Spaces to be filled when entering order	Weight of base mount unit	
2.4	580.70	450	3.82	17000	F 0 7 4 2 5 6 0 _ M _ _ _ _ . 1 2 A - -	78	63
2.1	658.49	510	3.65	17000	6 3 0		
1.9	726.31	563	3.36	17000	7 1 0		
1.7	831.78	645	2.93	17000	8 0 0		
1.5	944.37	732	2.58	17000	9 0 0		
1.4	1039.95	806	2.35	17000	1 0 C		
1.3	1090.34	845	2.24	17000	1 1 C		
1.2	1196.20	927	2.04	17000	1 2 C		
1.0	1350.14	1046	1.81	17000	1 4 C		
0.89	1570.72	1217	1.55	17000	1 6 C		
0.79	1769.83	1371	1.38	17000	1 8 C		
0.68	2051.65	1590	1.19	17000	2 0 C		
0.61	2311.71	1791	1.06	17000	2 2 C		
0.57	2453.97	1902	0.99	17000	2 5 C		
0.50	2785.27	2158	0.88	17000	2 8 C		
1.3	1084.58	840	3.81	19700	F 0 8 4 2 1 1 C _ M _ _ _ _ . 1 2 A - -	140	63
1.2	1191.37	923	3.47	19700	1 2 C		
1.0	1411.94	1094	2.92	19700	1 4 C		
0.88	1594.33	1235	2.59	19700	1 6 C		
0.74	1889.50	1464	2.19	19700	1 8 C		
0.70	2017.40	1563	2.05	19700	2 0 C		
0.61	2292.50	1776	1.80	19700	2 2 C		
0.56	2503.41	1940	1.65	19700	2 5 C		
0.52	2703.33	2095	1.53	19700	2 8 C		
0.43	3232.43	2505	1.28	19700	3 2 C		
0.39	3627.69	2811	1.14	19700	3 6 C		
0.35	3961.44	3070	1.04	19700	4 0 C		
0.32	4415.36	3421	0.94	19700	4 5 C		
0.28	4951.80	3837	0.83	19700	5 0 C		
1.0	1395.15	1081	3.91	32000	F 0 9 4 1 1 4 C _ M _ _ _ _ . 1 2 A - -	205	63
0.9	1520.27	1178	3.59	32000	1 6 C		
0.8	1801.73	1396	3.03	32000	1 8 C		
0.7	1923.69	1491	2.84	32000	2 0 C		
0.6	2179.69	1689	2.50	32000	2 2 C		
0.6	2387.13	1850	2.29	32000	2 5 C		
0.5	2814.91	2181	1.94	32000	2 8 C		
0.5	3082.28	2388	1.77	32000	3 2 C		
0.4	3656.25	2833	1.49	32000	3 6 C		
0.4	3777.43	2927	1.45	32000	4 0 C		
0.3	4210.26	3262	1.30	32000	4 5 C		
0.3	4721.79	3659	1.16	32000	5 0 C		
0.3	5309.53	4114	1.03	32000	5 6 C		

0.12 kW

6 POLE

154	5.90	7	9.42	1630	F 0 2 2 2 6 . 3 _ M _ _ _ _ . 1 2 C - -	16	63
114	7.97	10	8.10	1820	7 . 1		
100	9.07	11	7.56	1909	9 . 0		
89	10.27	12	7.05	1992	1 0 .		
69	13.14	16	6.02	2185	1 2 .		
64	14.16	17	5.76	2246	1 4 .		
51	17.88	22	5.05	2440	1 6 .		
45	20.27	25	4.70	2554	2 0 .		
39	23.16	29	4.32	2691	2 2 .		
35	25.77	32	4.06	2800	2 5 .		
32	28.41	35	3.71	2893	2 8 .		
29	31.26	38	3.37	2999	3 2 .		
25	36.63	44	2.90	3166	3 6 .		
21	43.94	53	2.44	3374	4 0 .		
18	51.22	62	2.09	3569	5 0 .		
16.1	56.91	69	1.87	3719	5 6 .		
13.3	68.54	83	1.55	3860	6 3 .		
11.6	78.56	95	1.18	3860	7 1 .		
10.2	89.28	108	1.03	3860	9 0 .		
10	92.02	109	1.23	3860	F 0 2 3 2 9 0 . _ M _ _ _ _ . 1 2 C - -	17	63
9.0	101.45	121	1.15	3860	1 0 0		
8.2	111.65	133	1.05	3860	1 1 2		
7.0	130.81	156	0.92	3860	1 2 5		
11	82.18	99	2.96	7100	F 0 3 2 2 9 0 . _ M _ _ _ _ . 1 2 C - -	23	63
10	93.43	112	2.33	7100	1 0 0		
9.1	99.52	119	3.49	7100	F 0 3 3 2 1 0 0 _ M _ _ _ _ . 1 2 C - -	24	63
8.3	109.72	131	3.22	7100	1 1 2		
7.5	120.75	144	2.96	7100	1 2 5		
6.4	141.47	169	2.54	7100	1 6 0		
5.4	169.72	203	2.13	7100	1 8 0		
4.6	197.84	236	1.86	7100	2 0 0		
4.1	219.82	262	1.68	7100	2 2 5		
3.4	264.71	316	1.40	7100	2 8 0		
3.0	303.42	362	1.19	7100	3 1 5		
2.6	344.83	410	1.03	7100	3 6 0		
11	82.18	99	2.96	7100	F 0 4 2 2 9 0 . _ M _ _ _ _ . 1 2 C - -	23	63
10	93.43	112	2.33	7100	1 0 0		

NOTE
Other output speeds are available using 2 and 8 pole motors - Please contact our Application Engineers

SERIES F

SELECTION TABLES

GEARED MOTORS

0.12 kW

6 POLE

N2 R/MIN	i	M2 Nm	Fm	N	Unit Designation	Kg	Motor Sizes
Output Speed	Ratio	Output Torque	Service Factor	Overhung Load	Column Entry [1] Through [20] Spaces to be filled when entering order	Weight of base mount unit	
9.1	99.52	119	3.49	7100	F 0 4 3 2 1 0 0 _ M _ _ _ _ . 1 2 C - -	24	63
8.3	109.72	131	3.22	7100	1 1 2		
7.5	120.75	144	2.96	7100	1 2 5		
6.4	141.47	169	2.54	7100	1 6 0		
5.4	169.72	203	2.13	7100	1 8 0		
4.6	197.84	236	1.86	7100	2 0 0		
4.1	219.82	262	1.68	7100	2 2 5		
3.4	264.71	316	1.40	7100	2 8 0		
3.0	303.42	362	1.19	7100	3 1 5		
2.6	344.83	410	1.03	7100	3 6 0		
5.2	176.23	210	3.66	9200	F 0 5 3 2 1 8 0 _ M _ _ _ _ . 1 2 C - -	32	63
4.4	204.87	245	3.14	9200	2 0 0		
3.9	232.53	278	2.73	9200	2 2 5		
3.4	264.35	316	2.15	9200	2 8 0		
2.9	314.39	378	1.72	9200	F 0 5 4 2 3 2 0 _ M _ _ _ _ . 1 2 C - -	44	63
2.6	351.75	423	1.60	9200	3 6 0		
2.2	412.85	497	1.37	9200	4 0 0		
2.0	444.31	535	1.27	9200	4 5 0		
1.8	489.28	589	1.15	9200	5 0 0		
1.6	562.80	677	1.00	9200	5 6 0		
1.5	611.86	736	0.92	9200	6 3 0		
1.3	694.17	835	0.81	9200	7 0 0		
4.5	201.07	241	3.91	11300	F 0 6 3 2 2 0 0 _ M _ _ _ _ . 1 2 C - -	47	63
4.0	226.56	271	3.54	11300	2 2 5		
3.5	263.38	316	3.11	11300	2 8 0		
3.0	298.94	358	2.73	11300	3 1 5		
2.7	339.84	407	2.15	11300	3 6 0		
2.2	404.18	486	1.72	11300	F 0 6 4 2 4 0 0 _ M _ _ _ _ . 1 2 C - -	58	63
2.0	445.09	535	1.57	11300	4 5 0		
1.8	497.98	599	1.47	11300	5 0 0		
1.6	571.21	687	1.30	11300	5 6 0		
1.4	629.02	757	1.18	11300	6 3 0		
1.3	723.53	870	1.03	11300	7 0 0		
1.2	786.61	946	0.94	11300	8 0 0		
1.0	892.42	1074	0.84	11300	9 0 0		
2.2	404.11	486	3.27	17000	F 0 7 4 2 4 0 0 _ M _ _ _ _ . 1 2 C - -	78	63
1.9	464.36	559	3.08	17000	4 5 0		
1.7	534.13	643	2.68	17000	5 0 0		
1.6	580.70	699	2.46	17000	5 6 0		
1.4	658.49	792	2.35	17000	6 3 0		
1.2	726.31	874	2.16	17000	7 0 0		
1.1	831.78	1001	1.89	17000	8 0 0		
1.0	944.37	1136	1.66	17000	9 0 0		
0.87	1039.95	1251	1.51	17000	1 0 C		
0.83	1090.34	1312	1.44	17000	1 1 C		
0.76	1196.20	1439	1.31	17000	1 2 C		
0.67	1350.14	1624	1.16	17000	1 4 C		
0.58	1570.72	1890	1.00	17000	1 6 C		
0.51	1769.83	2129	0.89	17000	1 8 C		
1.4	637.69	767	3.61	19700	F 0 8 4 2 6 3 0 _ M _ _ _ _ . 1 2 C - -	140	63
1.3	679.67	818	3.39	19700	7 0 0		
1.1	805.50	969	2.86	19700	8 0 0		
1.0	909.51	1094	2.92	19700	9 0 0		
0.89	1017.59	1224	2.61	19700	1 0 C		
0.83	1084.58	1305	2.45	19700	1 1 C		
0.76	1191.37	1433	2.23	19700	1 2 C		
0.64	1411.94	1699	1.88	19700	1 4 C		
0.57	1594.33	1918	1.67	19700	1 6 C		
0.48	1889.50	2273	1.41	19700	1 8 C		
0.45	2017.40	2427	1.32	19700	2 0 C		
0.39	2292.50	2758	1.16	19700	2 2 C		
0.36	2503.41	3012	1.06	19700	2 5 C		
0.33	2703.33	3252	0.98	19700	2 8 C		
0.28	3232.43	3889	0.82	19700	3 2 C		
0.98	926.74	1115	3.79	32000	F 0 9 4 1 9 0 0 _ M _ _ _ _ . 1 2 C - -	205	63
0.87	1036.86	1247	3.39	32000	1 0 C		
0.82	1105.12	1329	3.18	32000	1 1 C		
0.77	1177.20	1416	2.99	32000	1 2 C		
0.65	1395.15	1678	2.52	32000	1 4 C		
0.60	1520.27	1829	2.31	32000	1 6 C		
0.50	1801.73	2167	1.95	32000	1 8 C		
0.47	1923.69	2314	1.83	32000	2 0 C		
0.42	2179.69	2622	1.61	32000	2 2 C		
0.38	2387.13	2872	1.47	32000	2 5 C		
0.32	2814.91	3386	1.25	32000	2 8 C		
0.29	3082.28	3708	1.14	32000	3 2 C		
0.25	3656.25	4398	0.96	32000	3 6 C		
0.24	3777.43	4544	0.93	32000	4 0 C		
0.21	4210.26	5065	0.84	32000	4 5 C		

NOTE
Other output speeds are available using 2 and 8 pole motors - Please contact our Application Engineers

SERIES F

SELECTION TABLES

GEARED MOTORS

0.18 kW

4 POLE

N2 R/MIN	i	M2 Nm	Fm	N	Unit Designation	Kg	Motor Sizes
Output Speed	Ratio	Output Torque	Service Factor	Overhung Load	Column Entry [1] Through [20] Spaces to be filled when entering order	Weight of base mount unit	
232	5.90	7	0.00	1392	F 0 2 2 2 6 . 3 _ M _ _ _ _ . 1 8 A - -	16	63
173	7.97	10	5.39	1563	7 . 1		
152	9.07	11	4.73	1638	9 . 0		
134	10.27	12	4.18	1715	1 0 .		
105	13.14	16	3.27	1875	1 2 .		
97	14.16	17	3.03	1930	1 4 .		
77	17.88	22	2.41	2100	1 6 .		
68	20.27	25	2.12	2197	2 0 .		
60	23.16	28	1.86	2300	2 2 .		
54	25.77	31	1.67	2390	2 5 .		
49	28.41	34	1.52	2476	2 8 .		
44	31.26	38	1.37	2576	3 2 .		
38	36.63	44	1.17	2717	3 6 .		
31	43.94	54	0.98	2927	4 0 .		
27	51.22	62	0.84	3078	5 0 .		
15	92.02	108	1.19	3860	F 0 2 3 2 9 0 . _ M _ _ _ _ . 1 8 A - -	17	63
14	101.45	118	1.09	3860	1 0 0		
13	111.65	130	1.00	3860	1 1 2		
11	130.80	153	0.87	3860	1 2 5		
19	72.41	86	3.62	7100	F 0 3 2 2 7 1 . _ M _ _ _ _ . 1 8 A - -	23	63
17	82.18	98	2.87	7100	9 0 .		
15	93.43	111	2.26	7100	1 0 0		
14	99.52	117	3.10	7100	F 0 3 3 2 1 0 0 _ M _ _ _ _ . 1 8 A - -	24	63
13	109.72	130	2.91	7100	1 1 2		
11	120.75	143	2.78	7100	1 2 5		
10	141.47	167	2.46	7100	1 6 0		
8.1	169.72	200	2.11	7100	1 8 0		
7.0	197.84	234	1.86	7100	2 0 0		
6.3	219.82	259	1.70	7100	2 2 5		
5.2	264.71	313	1.41	7100	2 8 0		
4.5	303.42	358	1.21	7100	3 1 5		
4.0	344.83	408	1.04	7100	3 6 0		
19	72.41	86	3.62	7100	F 0 4 2 2 7 1 . _ M _ _ _ _ . 1 8 A - -	23	63
17	82.18	98	2.87	7100	9 0 .		
15	93.43	111	2.26	7100	1 0 0		
14	99.52	117	3.10	7100	F 0 4 3 2 1 0 0 _ M _ _ _ _ . 1 8 A - -	24	63
13	109.72	130	2.91	7100	1 1 2		
11	120.75	143	2.78	7100	1 2 5		
10	141.47	167	2.46	7100	1 6 0		
8.1	169.72	200	2.11	7100	1 8 0		
7.0	197.84	234	1.86	7100	2 0 0		
6.3	219.82	259	1.70	7100	2 2 5		
5.2	264.71	313	1.41	7100	2 8 0		
4.5	303.42	358	1.21	7100	3 1 5		
4.0	344.83	408	1.04	7100	3 6 0		
11	130.34	154	3.93	9200	F 0 5 3 2 1 2 5 _ M _ _ _ _ . 1 8 A - -	32	63
8.8	156.40	185	3.51	9200	1 6 0		
7.8	176.23	208	3.27	9200	1 8 0		
6.7	204.87	242	3.00	9200	2 0 0		
5.9	232.53	275	2.65	9200	2 2 5		
5.2	264.35	312	2.08	9200	2 8 0		
4.5	314.39	365	1.78	9200	F 0 5 4 2 3 2 0 _ M _ _ _ _ . 1 8 A - -	44	63
4.0	351.75	409	1.66	9200	3 6 0		
3.4	412.85	480	1.41	9200	4 0 0		
3.2	444.31	516	1.31	9200	4 5 0		
2.9	489.28	569	1.19	9200	5 0 0		
2.5	562.80	654	1.04	9200	5 6 0		
2.3	611.86	711	0.95	9200	6 3 0		
2.0	694.17	807	0.84	9200	7 0 0		
8.2	167.56	199	3.93	11300	F 0 6 3 2 1 8 0 _ M _ _ _ _ . 1 8 A - -	47	63
6.9	201.07	238	3.51	11300	2 0 0		
6.1	226.56	268	3.27	11300	2 2 5		
5.2	263.38	312	2.95	11300	2 8 0		
4.6	298.94	354	2.65	11300	3 1 5		
4.1	339.84	402	2.08	11300	3 6 0		
3.5	404.18	470	1.78	11300	F 0 6 4 2 4 0 0 _ M _ _ _ _ . 1 8 A - -	58	63
3.2	445.09	517	1.62	11300	4 5 0		
2.8	497.98	579	1.52	11300	5 0 0		
2.5	571.21	664	1.35	11300	5 6 0		
2.2	629.02	731	1.22	11300	6 3 0		
1.9	723.53	841	1.06	11300	7 0 0		
1.8	786.61	914	0.98	11300	8 0 0		
1.6	892.42	1037	0.87	11300	9 0 0		

NOTE
Other output speeds are available using 2 and 8 pole motors - Please contact our Application Engineers

SERIES F

SELECTION TABLES

GEARED MOTORS

0.18 kW

N2 R/MIN	i	M2 Nm	Fm	N	Unit Designation	Kg	
Output Speed	Ratio	Output Torque	Service Factor	Overhung Load	Column Entry [1] Through [20] Spaces to be filled when entering order	Weight of base mount unit	Motor Sizes
3.5	404.11	470	3.39	17000	F 0 7 4 2 4 0 0 _ M _ _ _ _ . 1 8 A - -	78	63
3.0	464.36	540	3.19	17000	4 5 0 0		
2.6	534.13	621	2.77	17000	5 0 0 0		
2.4	580.70	675	2.55	17000	5 6 0 0		
2.1	658.49	765	2.43	17000	6 3 0 0		
1.9	726.31	844	2.24	17000	7 0 0 0		
1.7	831.78	967	1.95	17000	8 0 0 0		
1.5	944.37	1098	1.72	17000	9 0 0 0		
1.4	1039.95	1209	1.56	17000	1 0 C		
1.3	1090.34	1267	1.49	17000	1 1 C		
1.2	1196.20	1390	1.36	17000	1 2 C		
1.0	1350.14	1569	1.20	17000	1 4 C		
0.89	1570.72	1826	1.04	17000	1 6 C		
0.79	1769.83	2057	0.92	17000	1 8 C		
2.2	637.69	741	3.74	19700	F 0 8 4 2 6 3 0 _ M _ _ _ _ . 1 8 A - -	140	63
2.1	679.67	790	3.51	19700	7 0 0 0		
1.7	805.50	936	2.96	19700	8 0 0 0		
1.5	909.51	1057	3.03	19700	9 0 0 0		
1.4	1017.59	1183	2.71	19700	1 0 C		
1.3	1084.58	1261	2.54	19700	1 1 C		
1.2	1191.37	1385	2.31	19700	1 2 C		
1.0	1411.94	1641	1.95	19700	1 4 C		
0.88	1594.33	1853	1.73	19700	1 6 C		
0.74	1889.50	2196	1.46	19700	1 8 C		
0.70	2017.40	2345	1.36	19700	2 0 C		
0.61	2292.50	2665	1.20	19700	2 2 C		
0.56	2503.41	2910	1.10	19700	2 5 C		
0.52	2703.33	3142	1.02	19700	2 8 C		
0.43	3232.43	3757	0.85	19700	3 2 C		
1.5	926.74	1077	3.93	32000	F 0 9 4 1 9 0 0 _ M _ _ _ _ . 1 8 A - -	205	63
1.4	1036.86	1205	3.51	32000	1 0 C		
1.3	1105.12	1284	3.29	32000	1 1 C		
1.2	1177.20	1368	3.09	32000	1 2 C		
1.0	1395.15	1622	2.61	32000	1 4 C		
0.92	1520.27	1767	2.39	32000	1 6 C		
0.78	1801.73	2094	2.02	32000	1 8 C		
0.73	1923.69	2236	1.89	32000	2 0 C		
0.64	2179.69	2533	1.67	32000	2 2 C		
0.59	2387.13	2775	1.52	32000	2 5 C		
0.50	2814.91	3272	1.29	32000	2 8 C		
0.46	3082.28	3583	1.18	32000	3 2 C		
0.38	3656.25	4250	1.00	32000	3 6 C		
0.37	3777.43	4391	0.96	32000	4 0 C		
0.33	4210.26	4894	0.86	32000	4 5 C		

0.18 kW

6 POLE

156	5.90	10	6.80	1623	F 0 2 2 2 6 . 3 _ M _ _ _ _ . 1 8 C - -	17.5	71
115	7.97	14	5.45	1814	7 . 1		
101	9.07	17	5.09	1902	9 . 0		
90	10.27	19	4.75	1983	1 0 .		
70	13.14	24	4.07	2174	1 2 .		
65	14.16	26	3.90	2234	1 4 .		
51	17.88	33	3.36	2440	1 6 .		
45	20.27	37	3.13	2554	2 0 .		
40	23.16	42	2.95	2667	2 2 .		
36	25.77	46	2.79	2771	2 5 .		
32	28.41	52	2.48	2893	2 8 .		
29	31.26	57	2.24	2999	3 2 .		
25	36.63	67	1.93	3166	3 6 .		
21	43.94	79	1.62	3374	4 0 .		
18	51.22	93	1.39	3569	5 0 .		
16	56.91	104	1.24	3719	5 6 .		
13	68.54	125	1.03	3860	6 3 .		
12	78.56	143	0.90	3860	7 1 .		
10	89.28	163	0.80	3860	9 0 .		
17	55.28	99	3.88	7100	F 0 3 2 2 5 6 . _ M _ _ _ _ . 1 8 C - -	24.5	71
15	62.29	111	3.38	7100	6 3 .		
13	72.41	130	2.51	7100	7 1 .		
11	82.18	147	2.00	7100	9 0 .		
10	93.43	167	1.57	7100	1 0 0		
9.2	99.52	177	2.35	7100	F 0 3 3 2 1 0 0 _ M _ _ _ _ . 1 8 C - -	25.5	71
8.4	109.72	195	2.17	7100	1 1 2		
7.6	120.75	214	2.00	7100	1 2 5		
6.5	141.47	251	1.71	7100	1 6 0		
5.4	169.72	301	1.44	7100	1 8 0		
4.7	197.84	350	1.26	7100	2 0 0		
4.2	219.82	388	1.13	7100	2 2 5		
3.5	264.71	469	0.94	7100	2 8 0		
3.0	303.42	537	0.80	7100	3 1 5		
17	55.28	99	3.88	7100	F 0 4 2 2 5 6 . _ M _ _ _ _ . 1 8 C - -	24.5	71
15	62.29	111	3.38	7100	6 3 .		
13	72.41	130	2.51	7100	7 1 .		
11	82.18	147	2.00	7100	9 0 .		
10	93.43	167	1.57	7100	1 0 0		

NOTE

Other output speeds are available using 2 and 8 pole motors - Please contact our Application Engineers

SERIES F

SELECTION TABLES

GEARED MOTORS

0.18 kW

6 POLE

N2 R/MIN	i	M2 Nm	Fm	N	Unit Designation	Kg	Motor Sizes		
Output Speed	Ratio	Output Torque	Service Factor	Overhung Load	Column Entry [1] Through [20] Spaces to be filled when entering order	Weight of base mount unit			
9.2	99.52	177	2.35	7100	F 0 4 3 2 1 0 0 _ M _ _ _ _ . 1 8 C - -	25.5	71		
8.4	109.72	195	2.17	7100	1 1 2				
7.6	120.75	214	2.00	7100	1 2 5				
6.5	141.47	251	1.71	7100	1 6 0				
5.4	169.72	301	1.44	7100	1 8 0				
4.7	197.84	350	1.26	7100	2 0 0				
4.2	219.82	388	1.13	7100	2 2 5				
3.5	264.71	469	0.94	7100	2 8 0				
3.0	303.42	537	0.80	7100	3 1 5				
13	72.92	130	2.78	9200	F 0 5 2 2 7 1 _ M _ _ _ _ . 1 8 C - -	32.5	71		
11	86.82	155	3.90	9200	F 0 5 3 2 9 0 _ M _ _ _ _ . 1 8 C - -			33.5	71
9.2	99.86	178	3.58	9200	1 0 0				
8.5	108.57	193	3.41	9200	1 1 2				
7.1	130.34	232	3.07	9200	1 2 5				
5.9	156.40	278	2.74	9200	1 6 0				
5.2	176.23	312	2.47	9200	1 8 0				
4.5	204.87	364	2.11	9200	2 0 0				
4.0	232.53	413	1.84	9200	2 2 5				
3.5	264.35	468	1.45	9200	2 8 0				
2.9	314.39	567	1.15	9200	F 0 5 4 2 3 2 0 _ M _ _ _ _ . 1 8 C - -	44.5	71		
2.6	351.75	635	1.07	9200	3 6 0				
2.2	412.85	745	0.91	9200	4 0 0				
2.0	444.31	802	0.85	9200	4 5 0				
10	93.75	168	2.78	11300	F 0 6 2 2 1 0 0 _ M _ _ _ _ . 1 8 C - -	47.5	71		
8.2	111.62	199	3.90	11300	F 0 6 3 2 1 1 2 _ M _ _ _ _ . 1 8 C - -			48.5	71
7.2	128.39	229	3.58	11300	1 2 5				
6.6	139.58	249	3.41	11300	1 6 0				
5.5	167.56	299	3.06	11300	1 8 0				
4.6	201.07	358	2.64	11300	2 0 0				
4.1	226.56	403	2.39	11300	2 2 5				
3.5	263.38	469	2.10	11300	2 8 0				
3.1	298.94	532	1.84	11300	3 1 5				
2.7	339.84	604	1.45	11300	3 6 0				
2.2	404.18	729	1.15	11300	F 0 6 4 2 4 0 0 _ M _ _ _ _ . 1 8 C - -	59.5	71		
2.0	445.09	803	1.04	11300	4 5 0				
1.8	497.98	899	0.98	11300	5 0 0				
1.6	571.21	1031	0.87	11300	5 6 0				
2.2	404.11	729	2.18	17000	F 0 7 4 2 4 0 0 _ M _ _ _ _ . 1 8 C - -	79.5	71		
1.9	464.36	838	2.05	17000	4 5 0				
1.7	534.13	964	1.78	17000	5 0 0				
1.6	580.70	1048	1.64	17000	5 6 0				
1.4	658.49	1188	1.57	17000	6 3 0				
1.2	726.31	1311	1.44	17000	7 0 0				
1.1	831.78	1501	1.26	17000	8 0 0				
1.0	944.37	1704	1.11	17000	9 0 0				
0.87	1039.95	1877	1.01	17000	1 0 C				
0.83	1090.34	1967	0.96	17000	1 1 C				
2.3	395.81	714	3.78	19000	F 0 8 4 2 4 0 0 _ M _ _ _ _ . 1 8 C - -			141	71
2.0	460.35	831	3.25	19000	4 5 0				
1.8	490.05	884	3.13	19000	5 0 0				
1.6	569.96	1028	2.69	19000	5 6 0				
1.4	637.69	1151	2.41	19000	6 3 0				
1.3	679.67	1226	2.26	19000	7 0 0				
1.1	805.50	1454	1.91	19000	8 0 0				
1.0	909.51	1641	1.95	19000	9 0 0				
0.89	1017.59	1836	1.74	19000	1 0 C				
0.83	1084.58	1957	1.64	19000	1 1 C				
0.76	1191.37	2150	1.49	19000	1 2 C				
0.64	1411.94	2548	1.26	19000	1 4 C				
0.57	1594.33	2877	1.11	19000	1 6 C				
0.48	1889.50	3410	0.94	19000	1 8 C				
0.45	2017.40	3640	0.88	19000	2 0 C				
1.5	594.29	1072	3.94	32000	F 0 9 4 1 5 6 0 _ M _ _ _ _ . 1 8 C - -	206	71		
1.4	664.91	1200	3.53	32000	6 3 0				
1.3	708.68	1279	3.31	32000	7 0 0				
1.1	839.89	1516	2.79	32000	8 0 0				
1.0	926.74	1672	2.53	32000	9 0 0				
0.87	1036.86	1871	2.26	32000	1 0 C				
0.82	1105.12	1994	2.12	32000	1 1 C				
0.77	1177.20	2124	1.99	32000	1 2 C				
0.65	1395.15	2518	1.68	32000	1 4 C				
0.60	1520.27	2743	1.54	32000	1 6 C				
0.50	1801.73	3251	1.30	32000	1 8 C				
0.47	1923.69	3471	1.22	32000	2 0 C				
0.42	2179.69	3933	1.08	32000	2 2 C				
0.38	2387.13	4308	0.98	32000	2 5 C				
0.32	2814.91	5079	0.83	32000	2 8 C				

NOTE
Other output speeds are available using 2 and 8 pole motors - Please contact our Application Engineers

SERIES F

SELECTION TABLES

GEARED MOTORS

0.25 kW

4 POLE

N2 R/MIN	i	M2 Nm	Fm	N	Unit Designation	Kg	Motor Sizes
Output Speed	Ratio	Output Torque	Service Factor	Overhung Load	Column Entry [1] Through [20] Spaces to be filled when entering order	Weight of base mount unit	
232	5.90	10	6.10	1404	F 0 2 2 2 6 . 3 _ M _ _ _ _ . 2 5 A - -	17.5	71
172	7.97	13	5.30	1566	7 . 1		
151	9.07	15	4.96	1642	9 . 0		
133	10.27	17	4.63	1720	1 0 .		
104	13.14	22	4.00	1882	1 2 .		
97	14.16	24	3.83	1930	1 4 .		
77	17.88	30	3.30	2100	1 6 .		
68	20.27	34	3.02	2197	2 0 .		
59	23.16	39	2.75	2314	2 2 .		
53	25.77	44	2.56	2406	2 5 .		
48	28.41	48	2.43	2495	2 8 .		
44	31.26	53	2.30	2576	3 2 .		
37	36.63	63	2.06	2744	3 6 .		
31	43.94	75	1.73	2927	4 0 .		
27	51.22	86	1.50	3078	5 0 .		
25	56.91	94	1.37	3184	5 6 .		
20	68.54	113	1.14	3408	6 3 .		
18	78.56	130	0.99	3582	7 1 .		
16	89.28	148	0.87	3753	9 0 .		
22	62.29	104	3.48	7100	F 0 3 2 2 6 3 . _ M _ _ _ _ . 2 5 A - -	24.5	71
19	72.41	121	2.59	7100	7 1 .		
17	82.18	137	2.05	7100	9 0 .		
15	93.43	156	1.61	7100	1 0 0		
14	99.52	164	2.22	7100	F 0 3 3 2 1 0 0 0 _ M _ _ _ _ . 2 5 A - -	25.5	71
12	109.72	182	2.08	7100	1 1 2		
11	120.75	200	1.98	7100	1 2 5		
10	141.47	235	1.76	7100	1 6 0		
8.1	169.72	281	1.51	7100	1 8 0		
6.9	197.84	327	1.33	7100	2 0 0		
6.2	219.82	363	1.21	7100	2 2 5		
5.2	264.71	438	1.01	7100	2 8 0		
4.5	303.42	501	0.86	7100	3 1 5		
22	62.29	104	3.48	7100	F 0 4 2 2 6 3 . _ M _ _ _ _ . 2 5 A - -	24.5	71
19	72.41	121	2.59	7100	7 1 .		
17	82.18	137	2.05	7100	9 0 .		
15	93.43	156	1.61	7100	1 0 0		
14	99.52	164	2.22	7100	F 0 4 3 2 1 0 0 0 _ M _ _ _ _ . 2 5 A - -	25.5	71
12	109.72	182	2.08	7100	1 1 2		
11	120.75	200	1.98	7100	1 2 5		
10	141.47	235	1.76	7100	1 6 0		
8.1	169.72	281	1.51	7100	1 8 0		
6.9	197.84	327	1.33	7100	2 0 0		
6.2	219.82	363	1.21	7100	2 2 5		
5.2	264.71	438	1.01	7100	2 8 0		
4.5	303.42	501	0.86	7100	3 1 5		
19	72.92	121	2.99	9200	F 0 5 2 2 7 1 . _ M _ _ _ _ . 2 5 A - -	33	71
16	86.82	144	3.59	9200	F 0 5 3 2 9 0 . _ M _ _ _ _ . 2 5 A - -	34	71
14	99.86	166	3.29	9200	1 0 0		
13	108.57	180	3.13	9200	1 1 2		
11	130.34	216	2.81	9200	1 2 5		
8.8	156.40	259	2.51	9200	1 6 0		
7.8	176.23	292	2.34	9200	1 8 0		
6.7	204.87	339	2.14	9200	2 0 0		
5.9	232.53	385	1.90	9200	2 2 5		
5.2	264.35	437	1.49	9200	2 8 0		
5.2	270.31	436	1.32	9200	F 0 5 4 2 3 2 0 0 _ M _ _ _ _ . 2 5 A - -	46	71
4.5	314.39	507	1.28	9200	3 6 0		
4.0	351.75	567	1.20	9200	4 0 0		
3.4	412.85	666	1.02	9200	4 5 0		
3.2	444.31	717	0.95	9200	5 0 0		
2.9	489.28	789	0.86	9200	5 6 0		
15	93.75	157	2.99	11300	F 0 6 2 2 1 0 0 0 _ M _ _ _ _ . 2 5 A - -	48	71
12	111.62	186	3.59	11300	F 0 6 3 2 1 1 2 _ M _ _ _ _ . 2 5 A - -	49	71
11	128.39	213	3.29	11300	1 2 5		
10	139.58	232	3.13	11300	1 6 0		
8.2	167.56	278	2.81	11300	1 8 0		
6.8	201.07	334	2.51	11300	2 0 0		
6.0	226.56	375	2.34	11300	2 2 5		
5.2	263.38	437	2.11	11300	2 8 0		
4.6	298.94	495	1.90	11300	3 1 5		
4.0	339.84	563	1.49	11300	3 6 0		
3.5	404.18	652	1.29	11300	F 0 6 4 2 4 0 0 0 _ M _ _ _ _ . 2 5 A - -	60	71
3.2	445.09	718	1.17	11300	3 6 0		
2.8	497.98	803	1.10	11300	4 0 0		
2.5	571.21	921	0.97	11300	4 5 0		
2.2	629.02	1015	0.88	11300	5 0 0		

NOTE
Other output speeds are available using 2 and 8 pole motors - Please contact our Application Engineers

SERIES F

SELECTION TABLES

GEARED MOTORS

0.25 kW

4 POLE

N2 R/MIN	i	M2 Nm	Fm	N	Unit Designation	Kg	Motor Sizes		
Output Speed	Ratio	Output Torque	Service Factor	Overhung Load	Column Entry [1] Through [20] Spaces to be filled when entering order	Weight of base mount unit			
3.5	404.11	652	2.44	17000	F 0 7 4 2 4 0 0 _ M _ _ _ _ . 2 5 A - -	80	71		
3.0	464.36	750	2.29	17000	4 5 0				
2.6	534.13	862	1.99	17000	5 0 0				
2.4	580.70	937	1.83	17000	5 6 0				
2.1	658.49	1063	1.75	17000	6 3 0				
1.9	726.31	1173	1.61	17000	7 0 0				
1.7	831.78	1343	1.41	17000	8 0 0				
1.5	944.37	1525	1.24	17000	9 0 0				
1.4	1039.95	1679	1.13	17000	1 0 C				
1.3	1090.34	1760	1.07	17000	1 1 C				
1.2	1196.20	1931	0.98	17000	1 2 C				
1.0	1350.14	2180	0.87	17000	1 4 C				
3.5	395.81	639	4.23	19700	F 0 8 4 2 4 0 0 _ M _ _ _ _ . 2 5 A - -			141	71
3.1	460.35	743	3.63	19700	4 5 0				
2.9	490.05	791	3.50	19700	5 0 0				
2.5	569.96	920	3.01	19700	5 6 0				
2.2	637.69	1029	2.69	19700	6 3 0				
2.1	679.67	1097	2.52	19700	7 0 0				
1.7	805.50	1300	2.13	19700	8 0 0				
1.5	909.51	1468	2.18	19700	9 0 0				
1.4	1017.59	1643	1.95	19700	1 0 C				
1.3	1084.58	1751	1.83	19700	1 1 C				
1.2	1191.37	1923	1.66	19700	1 2 C				
1.0	1411.94	2279	1.40	19700	1 4 C				
0.9	1594.33	2574	1.24	19700	1 6 C				
0.7	1889.50	3050	1.05	19700	1 8 C				
0.7	2017.40	3257	0.98	19700	2 0 C				
0.6	2292.50	3701	0.86	19700	2 2 C				
2.1	664.91	1073	3.94	32000	F 0 9 4 1 6 3 0 _ M _ _ _ _ . 2 5 A - -	206	71		
2.0	708.68	1144	3.70	32000	7 0 0				
1.7	839.89	1356	3.12	32000	8 0 0				
1.5	926.74	1496	2.83	32000	9 0 0				
1.4	1036.86	1674	2.53	32000	1 0 C				
1.3	1105.12	1784	2.37	32000	1 1 C				
1.2	1177.20	1900	2.23	32000	1 2 C				
1.0	1395.15	2252	1.88	32000	1 4 C				
0.9	1520.27	2454	1.72	32000	1 6 C				
0.8	1801.73	2909	1.45	32000	1 8 C				
0.7	1923.69	3105	1.36	32000	2 0 C				
0.6	2179.69	3519	1.20	32000	2 2 C				
0.6	2387.13	3854	1.10	32000	2 5 C				
0.5	2814.91	4544	0.93	32000	2 8 C				
0.5	3082.28	4976	0.85	32000	3 2 C				

0.25 kW

6 POLE

156	5.90	15	3.48	1623	F 0 2 2 2 6 . 3 _ M _ _ _ _ . 2 5 C - -	18.5	71
115	7.97	20	3.92	1814	7 . 1		
101	9.07	23	3.66	1902	9 . 0		
90	10.27	26	3.42	1983	1 0 .		
70	13.14	33	2.93	2174	1 2 .		
65	14.16	36	2.81	2234	1 4 .		
51	17.88	45	2.42	2440	1 6 .		
45	20.27	51	2.25	2554	2 0 .		
40	23.16	58	2.12	2667	2 2 .		
36	25.77	64	2.01	2771	2 5 .		
32	28.41	72	1.78	2893	2 8 .		
29	31.26	80	1.62	2999	3 2 .		
25	36.63	93	1.39	3166	3 6 .		
21	43.94	110	1.17	3374	4 0 .		
18	51.22	129	1.00	3569	5 0 .		
16	56.91	144	0.90	3719	5 6 .		
13	68.54	173	0.74	3980	6 3 .		
12	78.56	199	0.65	4184	7 1 .		
10	89.28	226	0.80	4384	9 0 .		
24	38.37	95	3.87	7200	F 0 3 2 2 4 0 . _ M _ _ _ _ . 2 5 C - -		
20	46.07	115	3.39	7200	5 0 .		
17	55.28	138	2.79	7200	5 6 .		
15	62.29	155	2.43	7200	6 3 .		
13	72.41	181	1.81	7200	7 1 .		
11	82.18	205	1.44	7200	9 0 .		
10	93.43	232	1.13	7200	1 0 0		
9.2	99.52	246	1.69	7200	F 0 3 3 2 1 0 0 _ M _ _ _ _ . 2 5 C - -	26.5	71
8.4	109.72	271	1.56	7200	1 1 2		
7.6	120.75	298	1.44	7200	1 2 5		
6.5	141.47	349	1.23	7200	1 6 0		
5.4	169.72	418	1.04	7200	1 8 0		
4.7	197.84	487	0.90	7200	2 0 0		
4.2	219.82	540	0.82	7200	2 2 5		
24	38.37	95	3.87	7200	F 0 4 2 2 4 0 . _ M _ _ _ _ . 2 5 C - -	25.5	71
20	46.07	115	3.39	7200	5 0 .		
17	55.28	138	2.79	7200	5 6 .		
15	62.29	155	2.43	7200	6 3 .		
13	72.41	181	1.81	7200	7 1 .		
11	82.18	205	1.44	7200	9 0 .		
10	93.43	232	1.13	7200	1 0 0		

NOTE
Other output speeds are available using 2 and 8 pole motors - Please contact our Application Engineers

SERIES F

SELECTION TABLES

GEARED MOTORS

0.25 kW

6 POLE

N2 R/MIN	i	M2 Nm	Fm	N	Unit Designation	Kg	Motor Sizes		
Output Speed	Ratio	Output Torque	Service Factor	Overhung Load	Column Entry [1] Through [20] Spaces to be filled when entering order	Weight of base mount unit			
9.2	99.52	246	1.69	7200	F 0 4 3 2 1 0 0 _ M _ _ _ _ . 2 5 C - -	26.5	71		
8.4	109.72	271	1.56	7200	1 1 2				
7.6	120.75	298	1.44	7200	1 2 5				
6.5	141.47	349	1.23	7200	1 6 0				
5.4	169.72	418	1.04	7200	1 8 0				
4.7	197.84	487	0.90	7200	2 0 0				
4.2	219.82	540	0.82	7200	2 2 5				
14	65.02	162	3.08	9200	F 0 5 2 2 6 3 _ _ M _ _ _ _ . 2 5 C - -	33.5	71		
13	72.92	181	2.00	9200	7 1 .				
12	78.84	195	3.15	9200	F 0 5 3 2 8 0 _ _ M _ _ _ _ . 2 5 C - -	34.5	71		
11	86.82	215	2.81	9200	9 0 .				
9.2	99.86	247	2.58	9200	1 0 0				
8.5	108.57	269	2.45	9200	1 1 2				
7.1	130.34	322	2.21	9200	1 2 5				
5.9	156.40	386	1.97	9200	1 6 0				
5.2	176.23	434	1.77	9200	1 8 0				
4.5	204.87	506	1.52	9200	2 0 0				
4.0	232.53	574	1.33	9200	2 2 5				
3.5	264.35	651	1.04	9200	2 8 0				
2.9	314.39	788	0.83	9200	F 0 5 4 2 3 2 0 _ M _ _ _ _ . 2 5 C - -			45.5	71
11	83.59	209	3.08	11300	F 0 6 2 2 9 0 _ _ M _ _ _ _ . 2 5 C - -				
10	93.75	233	2.00	11300	1 0 0				
9.1	101.36	251	3.15	11300	F 0 6 3 2 1 0 0 _ M _ _ _ _ . 2 5 C - -	49.5	71		
8.2	111.62	277	2.81	11300	1 1 2				
7.2	128.39	319	2.58	11300	1 2 5				
6.6	139.58	346	2.45	11300	1 6 0				
5.5	167.56	416	2.20	11300	1 8 0				
4.6	201.07	497	1.90	11300	2 0 0				
4.1	226.56	560	1.72	11300	2 2 5				
3.5	263.38	652	1.51	11300	2 8 0				
3.1	298.94	739	1.33	11300	3 1 5				
2.7	339.84	839	1.04	11300	3 6 0				
2.2	404.18	1013	0.83	11300	F 0 6 4 2 4 0 0 _ M _ _ _ _ . 2 5 C - -			60.5	71
2.2	404.11	1013	1.57	17000	F 0 7 4 2 4 0 0 _ M _ _ _ _ . 2 5 C - -	80.5	71		
1.9	464.36	1164	1.48	17000	4 5 0				
1.7	534.13	1339	1.28	17000	5 0 0				
1.6	580.70	1455	1.18	17000	5 6 0				
1.4	658.49	1650	1.13	17000	6 3 0				
1.2	726.31	1820	1.04	17000	7 0 0				
1.1	831.78	2085	0.91	17000	8 0 0				
1.0	944.37	2367	0.80	17000	9 0 0				
0.87	1039.95	2606	0.73	17000	1 0 C				
0.83	1090.34	2733	0.69	17000	1 1 C				
2.3	395.81	992	2.72	19700	F 0 8 4 2 4 0 0 _ M _ _ _ _ . 2 5 C - -			142	71
2.0	460.35	1154	2.34	19700	4 5 0				
1.8	490.05	1228	2.26	19700	5 0 0				
1.6	569.96	1428	1.94	19700	5 6 0				
1.4	637.69	1598	1.73	19700	6 3 0				
1.3	679.67	1703	1.63	19700	7 0 0				
1.1	805.50	2019	1.37	19700	8 0 0				
1.0	909.51	2279	1.40	19700	9 0 0				
0.89	1017.59	2550	1.25	19700	1 0 C				
0.83	1084.58	2718	1.18	19700	1 1 C				
0.76	1191.37	2986	1.07	19700	1 2 C				
0.64	1411.94	3539	0.90	19700	1 4 C				
0.57	1594.33	3996	0.80	19700	1 6 C				
2.0	460.18	1153	3.67	32000	F 0 9 4 1 4 5 0 _ M _ _ _ _ . 2 5 C - -	207	71		
1.8	510.96	1281	3.30	32000	5 0 0				
1.5	594.29	1489	2.84	32000	5 6 0				
1.4	664.91	1666	2.54	32000	6 3 0				
1.3	708.68	1776	2.38	32000	7 0 0				
1.1	839.89	2105	2.01	32000	8 0 0				
1.0	926.74	2323	1.82	32000	9 0 0				
0.87	1036.86	2599	1.63	32000	1 0 C				
0.82	1105.12	2770	1.53	32000	1 1 C				
0.77	1177.20	2950	1.43	32000	1 2 C				
0.65	1395.15	3497	1.21	32000	1 4 C				
0.60	1520.27	3810	1.11	32000	1 6 C				
0.50	1801.73	4516	0.94	32000	1 8 C				
0.47	1923.69	4821	0.88	32000	2 0 C				

NOTE
Other output speeds are available using 2 and 8 pole motors - Please contact our Application Engineers

SERIES F

SELECTION TABLES

GEARED MOTORS

0.37 kW

4 POLE

N2 R/MIN	i	M2 Nm	Fm	N	Unit Designation	Kg	Motor Sizes
Output Speed	Ratio	Output Torque	Service Factor	Overhung Load	Column Entry [1] Through [20] Spaces to be filled when entering order	Weight of base mount unit	
241	5.90	14	3.65	2080	F 0 2 2 2 6 . 3 _ M _ _ _ _ . 3 7 A - -	18.5	71
178	7.97	19	2.70	2258	7 . 1		
157	9.07	22	3.49	2327	9 . 0		
138	10.27	25	3.25	2403	1 0 .		
108	13.14	32	2.81	2554	1 2 .		
100	14.16	34	2.67	2594	1 4 .		
79	17.88	43	2.29	2730	1 6 .		
70	20.27	49	2.10	2793	2 0 .		
61	23.16	56	1.92	2865	2 2 .		
55	25.77	62	1.80	2914	2 5 .		
48	28.41	71	1.64	2495	2 8 .		
44	31.26	78	1.55	2576	3 2 .		
37	36.63	93	1.39	2744	3 6 .		
31	43.94	111	1.17	2927	4 0 .		
27	51.22	127	1.02	3078	5 0 .		
25	56.91	139	0.93	3184	5 6 .		
31	46.07	110	3.55	6690	F 0 3 2 2 5 0 . _ M _ _ _ _ . 3 7 A - -	25.5	71
26	55.28	132	2.91	6981	5 6 .		
23	62.29	149	2.44	7100	6 3 .		
20	72.41	173	1.81	7100	7 1 .		
17	82.18	196	1.44	7100	9 0 .		
15	93.43	222	1.13	7100	1 0 0		
14	99.52	235	1.55	7100	F 0 3 3 2 1 0 0 _ M _ _ _ _ . 3 7 A - -	26.5	71
13	109.72	260	1.46	7100	1 1 2		
12	120.75	286	1.39	7100	1 2 5		
10	141.47	335	1.23	7100	1 6 0		
8.4	169.72	401	1.06	7100	1 8 0		
7.2	197.84	467	0.93	7100	2 0 0		
6.5	219.82	519	0.85	7100	2 2 5		
31	46.07	110	3.55	6690	F 0 4 2 2 5 0 . _ M _ _ _ _ . 3 7 A - -	25.5	71
26	55.28	132	2.91	6981	5 6 .		
23	62.29	149	2.44	7100	6 3 .		
20	72.41	173	1.81	7100	7 1 .		
17	82.18	196	1.44	7100	9 0 .		
15	93.43	222	1.13	7100	1 0 0		
14	99.52	235	1.55	7100	F 0 4 3 2 1 0 0 _ M _ _ _ _ . 3 7 A - -	26.5	71
13	109.72	260	1.46	7100	1 1 2		
12	120.75	286	1.39	7100	1 2 5		
10	141.47	335	1.23	7100	1 6 0		
8.4	169.72	401	1.06	7100	1 8 0		
7.2	197.84	467	0.93	7100	2 0 0		
6.5	219.82	519	0.85	7100	2 2 5		
24	58.34	139	3.89	9200	F 0 5 2 2 5 6 . _ M _ _ _ _ . 3 7 A - -	33.5	71
22	65.02	155	3.10	9200	6 3 .		
19	72.92	174	2.09	9200	7 1 .		
18	78.84	187	2.83	9200	F 0 5 3 2 8 0 . _ M _ _ _ _ . 3 7 A - -	34.5	71
16	86.82	206	2.51	9200	9 0 .		
14	99.86	237	2.31	9200	1 0 0		
13	108.57	257	2.19	9200	1 1 2		
11	130.34	309	1.97	9200	1 2 5		
9.1	156.40	370	1.75	9200	1 6 0		
8.1	176.23	416	1.64	9200	1 8 0		
6.9	204.87	485	1.50	9200	2 0 0		
6.1	232.53	550	1.33	9200	2 2 5		
5.4	264.35	624	1.04	9200	2 8 0		
4.5	314.39	751	0.87	9200	F 0 5 4 2 3 2 0 _ M _ _ _ _ . 3 7 A - -	45.5	71
4.0	351.75	840	0.81	9200	3 6 0		
19	75.00	179	3.89	11300	F 0 6 2 2 7 1 . _ M _ _ _ _ . 3 7 A - -	48.5	71
17	83.59	199	3.10	11300	9 0 .		
15	93.75	224	2.09	11300	1 0 0		
14	101.36	240	2.83	11300	F 0 6 3 2 1 0 0 _ M _ _ _ _ . 3 7 A - -	49.5	71
13	111.62	265	2.51	11300	1 1 2		
11	128.39	305	2.31	11300	1 2 5		
10	139.58	332	2.19	11300	1 6 0		
8.5	167.56	398	1.97	11300	1 8 0		
7.1	201.07	476	1.75	11300	2 0 0		
6.3	226.56	536	1.64	11300	2 2 5		
5.4	263.38	624	1.48	11300	2 8 0		
4.8	298.94	708	1.33	11300	3 1 5		
4.2	339.84	804	1.04	11300	3 6 0		
3.5	404.18	966	0.87	11300	F 0 6 4 2 4 0 0 _ M _ _ _ _ . 3 7 A - -	60.5	71

NOTE
Other output speeds are available using 2 and 8 pole motors - Please contact our Application Engineers

SERIES F

SELECTION TABLES

GEARED MOTORS

0.37 kW

N2 R/MIN	i	M2 Nm	Fm	N	Unit Designation	Kg	
Output Speed	Ratio	Output Torque	Service Factor	Overhung Load	Column Entry [1] Through [20] Spaces to be filled when entering order	Weight of base mount unit	Motor Sizes
3.5	404.11	966	1.65	17000	F 0 7 4 2 4 0 0 _ M _ _ _ _ . 3 7 A - -	80.5	71
3.0	464.36	1109	1.55	17000	4 5 0		
2.6	534.13	1276	1.35	17000	5 0 0		
2.4	580.70	1387	1.24	17000	5 6 0		
2.1	658.49	1573	1.18	17000	6 3 0		
1.9	726.31	1735	1.09	17000	7 0 0		
1.7	831.78	1987	0.95	17000	8 0 0		
1.5	944.37	2256	0.84	17000	9 0 0		
3.5	395.81	946	2.86	19700	F 0 8 4 2 4 0 0 _ M _ _ _ _ . 3 7 A - -	142	71
3.1	460.35	1100	2.45	19700	4 5 0		
2.9	490.05	1171	2.37	19700	5 0 0		
2.5	569.96	1362	2.03	19700	5 6 0		
2.2	637.69	1524	1.82	19700	6 3 0		
2.1	679.67	1624	1.71	19700	7 0 0		
1.7	805.50	1925	1.44	19700	8 0 0		
1.5	909.51	2173	1.47	19700	9 0 0		
1.4	1017.59	2431	1.32	19700	1 0 C		
1.3	1084.58	2591	1.23	19700	1 1 C		
1.2	1191.37	2846	1.12	19700	1 2 C		
1.0	1411.94	3373	0.95	19700	1 4 C		
0.9	1594.33	3809	0.84	19700	1 6 C		
3.1	460.18	1099	3.85	32000	F 0 9 4 1 4 5 0 _ M _ _ _ _ . 3 7 A - -	207	71
2.7	510.96	1221	3.46	32000	5 0 0		
2.4	594.29	1420	2.98	32000	5 6 0		
2.1	664.91	1589	2.66	32000	6 3 0		
2.0	708.68	1693	2.50	32000	7 0 0		
1.7	839.89	2007	2.11	32000	8 0 0		
1.5	926.74	2214	1.91	32000	9 0 0		
1.4	1036.86	2477	1.71	32000	1 0 C		
1.3	1105.12	2640	1.60	32000	1 1 C		
1.2	1177.20	2813	1.50	32000	1 2 C		
1.0	1395.15	3333	1.27	32000	1 4 C		
0.9	1520.27	3632	1.16	32000	1 6 C		
0.8	1801.73	4305	0.98	32000	1 8 C		
0.7	1923.69	4596	0.92	32000	2 0 C		
0.6	2179.69	5208	0.81	32000	2 2 C		

0.37 kW

6 POLE

157	5.90	22	581	1619	F 0 2 2 2 6 . 3 _ M _ _ _ _ . 3 7 C - -	21	80A
116	7.97	30	430	1808	7 . 1		
102	9.07	34	378	1895	9 . 0		
90	10.27	38	334	1983	1 0 .		
70	13.14	49	261	2174	1 2 .		
65	14.16	53	242	2234	1 4 .		
51	17.88	67	192	2440	1 6 .		
45	20.27	76	1.52	2554	2 0 .		
40	23.16	86	1.44	2667	2 2 .		
36	25.77	95	1.35	2771	2 5 .		
32	28.41	107	1.20	2893	2 8 .		
29	31.26	118	1.09	2999	3 2 .		
25	36.63	137	0.82	3166	3 6 .		
33	27.86	102	3.65	6550	F 0 3 2 2 2 8 . _ M _ _ _ _ . 3 7 C - -	28	80A
30	30.68	113	3.31	6700	3 2 .		
26	35.30	130	3.02	6923	3 6 .		
24	38.37	141	2.63	7053	4 0 .		
20	46.07	170	2.30	7100	5 0 .		
17	55.28	203	1.90	7100	5 6 .		
15	62.29	228	1.65	7100	6 3 .		
13	72.41	266	1.23	7100	7 1 .		
11	82.18	302	0.98	7100	9 0 .		
9.3	99.52	362	1.15	7100	F 0 3 3 2 1 0 0 _ M _ _ _ _ . 3 7 C - -	29	80A
8.4	109.72	399	1.06	7100	1 1 2		
7.7	120.75	439	0.98	7100	1 2 5		
6.5	141.47	513	0.84	7100	1 6 0		
33	27.86	102	3.65	6550	F 0 4 2 2 2 8 . _ M _ _ _ _ . 3 7 C - -	28	80A
30	30.68	113	3.31	6700	3 2 .		
26	35.30	130	3.02	6923	3 6 .		
24	38.37	141	2.63	7053	4 0 .		
20	46.07	170	2.30	7100	5 0 .		
17	55.28	203	1.90	7100	5 6 .		
15	62.29	228	1.65	7100	6 3 .		
13	72.41	266	1.23	7100	7 1 .		
11	82.18	302	0.98	7100	9 0 .		
9.3	99.52	362	1.15	7100	F 0 4 3 2 1 0 0 _ M _ _ _ _ . 3 7 C - -	29	80A
8.4	109.72	399	1.06	7100	1 1 2		
7.7	120.75	439	0.98	7100	1 2 5		
6.5	141.47	513	0.84	7100	1 6 0		
16	58.34	215	2.63	9200	F 0 5 2 2 5 6 . _ M _ _ _ _ . 3 7 C - -	36	80A
14	65.02	239	2.09	9200	6 3 .		
13	72.92	267	1.36	9200	7 1 .		

NOTE
Other output speeds are available using 2 and 8 pole motors - Please contact our Application Engineers

SERIES F

SELECTION TABLES

GEARED MOTORS

0.37 kW

6 POLE

N2 R/MIN	i	M2 Nm	Fm	N	Unit Designation	Kg	Motor Sizes
Output Speed	Ratio	Output Torque	Service Factor	Overhung Load	Column Entry 1 Through 20 Spaces to be filled when entering order	Weight of base mount unit	
12	78.84	287	2.14	9200	F 0 5 3 2 8 0 . _ M _ _ _ _ . 3 7 C - -	37	80A
11	86.82	317	1.91	9200	9 0 .		
9.3	99.86	364	1.75	9200	1 0 0		
8.5	108.57	396	1.67	9200	1 1 2		
7.1	130.34	474	1.50	9200	1 2 5		
5.9	156.40	568	1.34	9200	1 6 0		
5.2	176.23	639	1.21	9200	1 8 0		
4.5	204.87	745	1.03	9200	2 0 0		
4.0	232.53	845	0.90	9200	2 2 5		
15	61.20	225	3.96	11300	F 0 6 2 2 6 3 . _ M _ _ _ _ . 3 7 C - -	51	80A
12	75.00	277	2.63	11300	7 1 .		
11	83.59	308	2.09	11300	9 0 .		
10	93.75	344	1.36	11300	1 0 0		
9.1	101.36	370	2.14	11300	F 0 6 3 2 1 0 0 _ M _ _ _ _ . 3 7 C - -	52	80A
8.3	111.62	408	1.91	11300	1 1 2		
7.2	128.39	469	1.75	11300	1 2 5		
6.6	139.58	510	1.67	11300	1 6 0		
5.5	167.56	612	1.50	11300	1 8 0		
4.6	201.07	732	1.29	11300	2 0 0		
4.1	226.56	824	1.17	11300	2 2 5		
3.5	263.38	960	1.03	11300	2 8 0		
3.1	298.94	1088	0.90	11300	3 1 5		
10	89.42	328	3.93	17000	F 0 7 2 2 9 0 . _ M _ _ _ _ . 3 7 C - -	72	80A
9.3	99.36	364	3.02	17000	1 0 0		
8.5	108.56	397	3.59	17000	F 0 7 3 2 1 0 0 _ M _ _ _ _ . 3 7 C - -	77	80A
8.0	115.70	423	3.26	17000	1 1 2		
6.7	137.12	499	2.94	17000	1 2 5		
6.3	146.40	531	2.84	17000	1 6 0		
5.1	181.67	662	2.49	17000	1 8 0		
4.3	214.23	783	2.26	17000	2 0 0		
3.9	234.58	854	2.14	17000	2 2 5		
3.2	287.49	1048	1.90	17000	2 8 0		
2.9	320.43	1167	1.80	17000	3 1 5		
2.6	359.36	1306	1.36	17000	3 6 0		
2.2	404.11	1499	1.06	17000	F 0 7 4 2 4 0 0 _ M _ _ _ _ . 3 7 C - -	83	80A
1.9	464.36	1722	1.00	17000	4 5 0		
1.7	534.13	1981	0.87	17000	5 0 0		
1.6	580.70	2154	0.80	17000	5 6 0		
3.7	247.74	903	3.91	19700	F 0 8 3 2 2 2 5 _ M _ _ _ _ . 3 7 C - -	125	80A
3.0	303.60	1105	3.26	19700	2 8 0		
2.8	331.53	1212	2.97	19700	3 1 5		
2.4	381.76	1389	2.59	19700	3 6 0		
2.3	395.81	1468	1.84	19700	F 0 8 4 2 4 0 0 _ M _ _ _ _ . 3 7 C - -	146	80A
2.0	460.35	1708	1.58	19700	4 5 0		
1.8	490.05	1818	1.52	19700	5 0 0		
1.6	569.96	2114	1.31	19700	5 6 0		
1.4	637.69	2365	1.17	19700	6 3 0		
1.3	679.67	2521	1.10	19700	7 0 0		
1.1	805.50	2988	0.93	19700	8 0 0		
1.0	909.51	3374	0.95	19700	9 0 0		
0.89	1017.59	3774	0.85	19700	1 0 C		
0.83	1084.58	4023	0.80	19700	1 1 C		
2.3	395.66	1468	2.88	32000	F 0 9 4 1 4 0 0 _ M _ _ _ _ . 3 7 C - -	211	80A
2.0	460.18	1707	2.48	32000	4 5 0		
1.8	510.96	1895	2.23	32000	5 0 0		
1.5	594.29	2204	1.92	32000	5 6 0		
1.4	664.91	2466	1.72	32000	6 3 0		
1.3	708.68	2629	1.61	32000	7 0 0		
1.1	839.89	3115	1.36	32000	8 0 0		
1.0	926.74	3437	1.23	32000	9 0 0		
0.9	1036.86	3846	1.10	32000	1 0 C		
0.8	1105.12	4099	1.03	32000	1 1 C		
0.8	1177.20	4366	0.97	32000	1 2 C		
0.6	1395.15	5175	0.82	32000	1 4 C		
1.8	489.83	1817	3.99	43000	F 1 0 4 1 5 0 0 _ M _ _ _ _ . 3 7 C - -	300	80A
1.6	562.85	2088	3.47	43000	5 6 0		
1.4	638.26	2367	3.06	43000	6 3 0		
1.3	703.99	2611	2.78	43000	7 0 0		
1.1	806.22	2990	2.42	43000	8 0 0		
1.0	924.82	3430	2.11	43000	9 0 0		
0.9	1048.72	3890	1.86	43000	1 0 C		
0.8	1156.73	4291	1.69	43000	1 1 C		
0.7	1324.70	4914	1.48	43000	1 2 C		
0.6	1497.76	5555	1.31	43000	1 4 C		
0.6	1564.43	5803	1.25	43000	1 6 C		
0.5	1791.60	6645	1.09	43000	1 8 C		
0.4	2025.66	7514	0.96	43000	2 0 C		
0.4	2348.52	8711	0.83	43000	2 2 C		

NOTE
Other output speeds are available using 2 and 8 pole motors - Please contact our Application Engineers

SERIES F

SELECTION TABLES

GEARED MOTORS

0.55 kW

4 POLE

N2 R/MIN	i	M2 Nm	Fm	N	Unit Designation	Kg	Motor Sizes
Output Speed	Ratio	Output Torque	Service Factor	Overhung Load	Column Entry [1] Through [20] Spaces to be filled when entering order	Weight of base mount unit	
235	5.90	22	2.81	1397	F 0 2 2 2 6 . 3 _ M _ _ _ _ . 5 5 A - -	21	80A
174	7.97	29	2.44	1559	7 . 1		
153	9.07	33	2.29	1634	9 . 0		
135	10.27	38	2.14	1711	1 0 .		
106	13.14	48	1.85	1868	1 2 .		
98	14.16	52	1.76	1923	1 4 .		
79	17.88	64	1.54	2080	1 6 .		
70	20.27	73	1.42	2174	2 0 .		
61	23.16	84	1.29	2286	2 2 .		
55	25.77	93	1.21	2374	2 5 .		
48	28.41	106	1.10	2495	2 8 .		
44	31.26	116	1.04	2576	3 2 .		
37	36.63	138	0.94	2744	3 6 .		
50	27.86	101	3.68	5614	F 0 3 2 2 2 8 . _ M _ _ _ _ . 5 5 A - -	28	80A
45	30.68	112	3.33	5738	3 2 .		
39	35.30	128	3.03	5912	3 6 .		
36	38.37	140	2.65	6014	4 0 .		
30	46.07	167	2.34	6229	5 0 .		
25	55.28	201	1.92	6428	5 6 .		
22	62.29	226	1.60	6552	6 3 .		
19	72.41	262	1.19	6673	7 1 .		
17	82.18	299	0.95	6765	9 0 .		
14	99.52	357	1.02	6874	F 0 3 3 2 1 0 0 _ M _ _ _ _ . 5 5 A - -	29	80A
13	109.72	395	0.96	6890	1 1 2		
12	120.75	434	0.92	6890	1 2 5		
10	141.47	509	0.81	6540	1 6 0		
50	27.86	101	3.68	5614	F 0 4 2 2 2 8 . _ M _ _ _ _ . 5 5 A - -	28	80A
45	30.68	112	3.33	5738	3 2 .		
39	35.30	128	3.03	5912	3 6 .		
36	38.37	140	2.65	6014	4 0 .		
30	46.07	167	2.34	6229	5 0 .		
25	55.28	201	1.92	6428	5 6 .		
22	62.29	226	1.60	6552	6 3 .		
19	72.41	262	1.19	6673	7 1 .		
17	82.18	299	0.95	6765	9 0 .		
14	99.52	357	1.02	6874	F 0 4 3 2 1 0 0 _ M _ _ _ _ . 5 5 A - -	29	80A
13	109.72	395	0.96	6890	1 1 2		
12	120.75	434	0.92	6890	1 2 5		
10	141.47	509	0.81	6540	1 6 0		
24	58.34	211	2.56	8858	F 0 5 2 2 5 6 . _ M _ _ _ _ . 5 5 A - -	36	80A
21	65.02	235	2.04	9053	6 3 .		
19	72.92	264	1.38	9200	7 1 .		
18	78.84	284	1.86	9200	F 0 5 3 2 8 0 . _ M _ _ _ _ . 5 5 A - -	37	80A
16	86.82	313	1.66	9200	9 0 .		
14	99.86	360	1.52	9200	1 0 0		
13	108.57	391	1.44	9200	1 1 2		
11	130.34	469	1.30	9200	1 2 5		
8.9	156.40	562	1.16	9200	1 6 0		
7.9	176.23	633	1.08	9200	1 8 0		
6.8	204.87	736	0.99	9200	2 0 0		
6.0	232.53	835	0.87	9200	2 2 5		
19	75.00	272	2.56	11300	F 0 6 2 2 7 1 . _ M _ _ _ _ . 5 5 A - -	51	80A
17	83.59	303	2.04	11300	9 0 .		
15	93.75	340	1.38	11300	1 0 0		
14	101.36	365	1.86	11300	F 0 6 3 2 1 0 0 _ M _ _ _ _ . 5 5 A - -	52	80A
12	111.62	403	1.66	11300	1 1 2		
11	128.39	463	1.52	11300	1 2 5		
10	139.58	504	1.44	11300	1 6 0		
8.3	167.56	604	1.30	11300	1 8 0		
6.9	201.07	724	1.16	11300	2 0 0		
6.1	226.56	815	1.08	11300	2 2 5		
5.3	263.38	949	0.97	11300	2 8 0		
4.6	298.94	1075	0.87	11300	3 1 5		
16	89.42	326	3.89	17000	F 0 7 2 2 9 0 . _ M _ _ _ _ . 5 5 A - -	72	80A
14	99.36	360	3.05	17000	1 0 0		
13	108.56	390	3.17	17000	F 0 7 3 2 1 0 0 _ M _ _ _ _ . 5 5 A - -	77	80A
12	115.70	418	2.84	17000	1 1 2		
10	137.12	495	2.56	17000	1 2 5		
9.5	146.40	528	2.46	17000	1 6 0		
7.7	181.67	657	2.16	17000	1 8 0		
6.5	214.23	773	1.95	17000	2 0 0		
5.9	234.58	849	1.85	17000	2 2 5		
4.8	287.49	1035	1.64	17000	2 8 0		
4.3	320.43	1153	1.57	17000	3 1 5		
3.9	359.36	1292	1.38	17000	3 6 0		

NOTE
Other output speeds are available using 2 and 8 pole motors - Please contact our Application Engineers

SERIES F

SELECTION TABLES

GEARED MOTORS

0.55 kW

N2 R/MIN	i	M2 Nm	Fm	N	Unit Designation	Kg	Motor Sizes
Output Speed	Ratio	Output Torque	Service Factor	Overhung Load	Column Entry [1] Through [20] Spaces to be filled when entering order	Weight of base mount unit	
3.5	404.11	1420	1.12	17000	F 0 7 4 2 4 0 0 _ M _ _ _ _ . 5 5 A - -	83	80A
3.1	464.36	1632	1.05	17000	4 5 0		
2.7	534.13	1877	0.92	17000	5 0 0		
2.4	580.70	2041	0.84	17000	5 6 0		
2.2	658.49	2314	0.80	17000	6 3 0		
5.6	247.74	892	3.80	19700	F 0 8 3 2 2 2 5 _ M _ _ _ _ . 5 5 A - -	125	80A
4.6	303.60	1096	3.12	19700	2 8 0		
4.2	331.53	1195	2.89	19700	3 1 5		
3.6	381.76	1372	2.58	19700	3 6 0		
3.6	395.81	1391	1.94	19700	F 0 8 4 2 4 0 0 _ M _ _ _ _ . 5 5 A - -	146	80A
3.1	460.35	1618	1.67	19700	4 5 0		
2.9	490.05	1722	1.61	19700	5 0 0		
2.5	569.96	2003	1.38	19700	5 6 0		
2.2	637.69	2241	1.24	19700	6 3 0		
2.1	679.67	2388	1.16	19700	7 0 0		
1.8	805.50	2831	0.98	19700	8 0 0		
1.6	909.51	3196	1.00	19700	9 0 0		
1.4	1017.59	3576	0.89	19700	1 0 C		
1.3	1084.58	3811	0.84	19700	1 1 C		
3.6	395.66	1390	3.04	32000	F 0 9 4 1 4 0 0 _ M _ _ _ _ . 5 5 A - -	211	80A
3.1	460.18	1617	2.62	32000	4 5 0		
2.8	510.96	1796	2.36	32000	5 0 0		
2.4	594.29	2088	2.03	32000	5 6 0		
2.1	664.91	2336	1.81	32000	6 3 0		
2.0	708.68	2490	1.70	32000	7 0 0		
1.7	839.89	2951	1.43	32000	8 0 0		
1.5	926.74	3257	1.30	32000	9 0 0		
1.4	1036.86	3644	1.16	32000	1 0 C		
1.3	1105.12	3883	1.09	32000	1 1 C		
1.2	1177.20	4137	1.02	32000	1 2 C		
1.0	1395.15	4903	0.86	32000	1 4 C		
2.5	562.85	1978	3.67	43000	F 1 0 4 1 5 6 0 _ M _ _ _ _ . 5 5 A - -	300	80A
2.2	638.26	2243	3.23	43000	6 3 0		
2.0	703.99	2474	2.93	43000	7 0 0		
1.8	806.22	2833	2.56	43000	8 0 0		
1.5	924.82	3250	2.23	43000	9 0 0		
1.4	1048.72	3685	1.97	43000	1 0 C		
1.2	1156.73	4065	1.78	43000	1 1 C		
1.1	1324.70	4655	1.56	43000	1 2 C		
0.95	1497.76	5263	1.38	43000	1 4 C		
0.91	1564.43	5497	1.32	43000	1 6 C		
0.79	1791.60	6296	1.15	43000	1 8 C		
0.70	2025.66	7118	1.02	43000	2 0 C		
0.60	2348.52	8253	0.88	43000	2 2 C		
0.56	2523.21	8867	0.80	43000	2 5 C		

0.55 kW

6 POLE

157	5.90	32	2.10	1619	F 0 2 2 2 6 . 3 _ M _ _ _ _ . 5 5 C - -	22	80B
116	7.97	44	1.80	1808	7 . 1		
102	9.07	50	1.68	1895	9 . 0		
90	10.27	57	1.55	1983	1 0 .		
70	13.14	73	1.33	2174	1 2 .		
65	14.16	78	1.28	2234	1 4 .		
51	17.88	100	1.10	2440	1 6 .		
45	20.27	113	1.02	2554	2 0 .		
40	23.16	127	0.97	2667	2 2 .		
36	25.77	142	0.91	2771	2 5 .		
32	28.41	159	0.81	2893	2 8 .		
29	31.26	176	0.73	2999	3 2 .		
25	36.63	204	0.55	3166	3 6 .		
48	19.46	107	3.54	5673	F 0 3 2 2 2 0 . _ M _ _ _ _ . 5 5 C - -	29	80B
43	21.59	118	3.21	5810	2 2 .		
38	24.53	135	2.86	5968	2 5 .		
33	27.86	152	2.45	6126	2 8 .		
30	30.68	168	2.22	6233	3 2 .		
26	35.30	193	2.03	6388	3 6 .		
24	38.37	209	1.77	6472	4 0 .		
20	46.07	252	1.55	6636	5 0 .		
17	55.28	303	1.28	6766	5 6 .		
15	62.29	340	1.11	6823	6 3 .		
13	72.41	396	0.83	6850	7 1 .		
48	19.46	107	3.54	5673	F 0 4 2 2 2 0 . _ M _ _ _ _ . 5 5 C - -	29	80B
43	21.59	118	3.21	5810	2 2 .		
38	24.53	135	2.86	5968	2 5 .		
33	27.86	152	2.45	6126	2 8 .		
30	30.68	168	2.22	6233	3 2 .		
26	35.30	193	2.03	6388	3 6 .		
24	38.37	209	1.77	6472	4 0 .		
20	46.07	252	1.55	6636	5 0 .		
17	55.28	303	1.28	6766	5 6 .		
15	62.29	340	1.11	6823	6 3 .		
13	72.41	396	0.83	6850	7 1 .		

NOTE

Other output speeds are available using 2 and 8 pole motors - Please contact our Application Engineers

SERIES F

SELECTION TABLES

GEARED MOTORS

0.55 kW

6 POLE

N2 R/MIN	i	M2 Nm	Fm	N	Unit Designation	Kg	Motor Sizes
Output Speed	Ratio	Output Torque	Service Factor	Overhung Load	Column Entry [1] Through [20] Spaces to be filled when entering order	Weight of base mount unit	
25	36.87	202	3.50	8770	F 0 5 2 2 3 6 . _ M _ _ _ _ . 5 5 C - -	37	80B
21	43.47	239	3.00	9060	4 0 .		
19	47.60	261	2.75	9200	5 0 .		
16	58.34	319	1.77	9200	5 6 .		
14	65.02	355	1.41	9200	6 3 .		
13	72.92	397	0.92	9200	7 1 .		
12	78.84	427	1.44	9200	F 0 5 3 2 8 0 . _ M _ _ _ _ . 5 5 C - -	38	80B
11	86.82	471	1.28	9200	9 0 .		
9.3	99.86	541	1.18	9200	1 0 0		
8.5	108.57	588	1.12	9200	1 1 2		
7.1	130.34	705	1.01	9200	1 2 5		
5.9	156.40	845	0.90	9200	1 6 0		
20	47.40	261	3.42	11300	F 0 6 2 2 5 0 . _ M _ _ _ _ . 5 5 C - -	52	80B
17	55.89	307	2.91	11300	5 6 .		
15	61.20	335	2.66	11300	6 3 .		
12	75.00	412	1.77	11300	7 1 .		
11	83.59	457	1.41	11300	9 0 .		
10	93.75	511	0.92	11300	1 0 0		
9.1	101.36	551	1.44	11300	F 0 6 3 2 1 0 0 _ M _ _ _ _ . 5 5 C - -	53	80B
8.3	111.62	607	1.28	11300	1 1 2		
7.2	128.39	698	1.18	11300	1 2 5		
6.6	139.58	759	1.12	11300	1 6 0		
5.5	167.56	910	1.01	11300	1 8 0		
4.6	201.07	1088	0.87	11300	2 0 0		
12	77.72	426	3.87	17000	F 0 7 2 2 7 1 . _ M _ _ _ _ . 5 5 C - -	73	80B
10	89.42	487	2.65	17000	9 0 .		
9.3	99.36	541	2.03	17000	1 0 0		
8.5	108.56	591	2.42	17000	F 0 7 3 2 1 0 0 _ M _ _ _ _ . 5 5 C - -	78	80B
8.0	115.70	630	2.19	17000	1 1 2		
6.7	137.12	742	1.98	17000	1 2 5		
6.3	146.40	790	1.91	17000	1 6 0		
5.1	181.67	985	1.67	17000	1 8 0		
4.3	214.23	1165	1.52	17000	2 0 0		
3.9	234.58	1270	1.44	17000	2 2 5		
3.2	287.49	1558	1.28	17000	2 8 0		
2.9	320.43	1734	1.21	17000	3 1 5		
2.6	359.36	1942	0.92	17000	3 6 0		
5.8	159.53	867	3.91	19700	F 0 8 3 2 1 6 0 _ M _ _ _ _ . 5 5 C - -	126	80B
4.8	193.39	1045	3.24	19700	1 8 0		
4.1	225.53	1226	2.84	19700	2 0 0		
3.7	247.74	1343	2.63	19700	2 2 5		
3.0	303.60	1643	2.19	19700	2 8 0		
2.8	331.53	1802	2.00	19700	3 1 5		
2.4	381.76	2065	1.74	19700	3 6 0		
2.3	395.81	2147	1.26	19700	F 0 8 4 2 4 0 0 _ M _ _ _ _ . 5 5 C - -	146	80B
2.0	460.35	2497	1.08	19700	4 5 0		
1.9	490.05	2658	1.04	19700	5 0 0		
1.6	569.96	3091	0.90	19700	5 6 0		
2.3	395.66	2146	1.97	32000	F 0 9 4 1 4 0 0 _ M _ _ _ _ . 5 5 C - -	212	80B
2.0	460.18	2496	1.69	32000	4 5 0		
1.8	510.96	2771	1.53	32000	5 0 0		
1.5	594.29	3223	1.31	32000	5 6 0		
1.4	664.91	3606	1.17	32000	6 3 0		
1.3	708.68	3844	1.10	32000	7 0 0		
1.1	839.89	4555	0.93	32000	8 0 0		
1.0	926.74	5026	0.84	32000	9 0 0		
2.7	343.57	1855	3.91	43000	F 1 0 3 1 3 6 0 _ M _ _ _ _ . 5 5 C - -	283	80B
2.3	400.73	2173	3.34	43000	F 1 0 4 1 4 0 0 _ M _ _ _ _ . 5 5 C - -	301	80B
2.1	445.30	2415	3.00	43000	4 5 0		
1.9	489.83	2657	2.73	43000	5 0 0		
1.6	562.85	3053	2.37	43000	5 6 0		
1.4	638.26	3462	2.09	43000	6 3 0		
1.3	703.99	3818	1.90	43000	7 0 0		
1.1	806.22	4373	1.66	43000	8 0 0		
1.0	924.82	5016	1.45	43000	9 0 0		
0.88	1048.72	5688	1.27	43000	1 0 C		
0.80	1156.73	6274	1.16	43000	1 1 C		
0.69	1324.70	7185	1.01	43000	1 2 C		
0.61	1497.76	8124	0.89	43000	1 4 C		
0.59	1564.43	8485	0.85	43000	1 6 C		

NOTE
Other output speeds are available using 2 and 8 pole motors - Please contact our Application Engineers

SERIES F

SELECTION TABLES

GEARED MOTORS

0.75 kW

4 POLE

N2 R/MIN	i	M2 Nm	Fm	N	Unit Designation	Kg	Motor Sizes
Output Speed	Ratio	Output Torque	Service Factor	Overhung Load	Column Entry [1] Through [20] Spaces to be filled when entering order	Weight of base mount unit	
239	5.90	29	2.09	1389	F 0 2 2 2 6 . 3 _ M _ _ _ _ . 7 5 A - -	22.5	80A
177	7.97	39	1.82	1550	7 . 1		
155	9.07	45	1.70	1626	9 . 0		
137	10.27	51	1.59	1701	1 0 .		
107	13.14	65	1.37	1862	1 2 .		
98	14.16	71	1.29	1923	1 4 .		
79	17.88	88	1.13	2080	1 6 .		
70	20.27	99	1.04	2174	2 0 .		
61	23.16	114	0.95	2286	2 2 .		
55	25.77	126	0.89	2374	2 5 .		
48	28.41	145	0.81	2495	2 8 .		
72	19.46	95	3.72	4921	F 0 3 2 2 2 0 . _ M _ _ _ _ . 7 5 A - -	29.5	80A
65	21.59	106	3.41	5037	2 2 .		
57	24.53	120	3.06	5165	2 5 .		
51	27.86	137	2.74	5302	2 8 .		
46	30.68	151	2.48	5394	3 2 .		
40	35.30	173	2.26	5518	3 6 .		
37	38.37	188	1.97	5586	4 0 .		
31	46.07	225	1.74	5718	5 0 .		
26	55.28	271	1.43	5814	5 6 .		
23	62.29	304	1.19	5860	6 3 .		
19	72.41	353	0.89	5870	7 1 .		
72	19.46	95	3.72	4921	F 0 4 2 2 2 0 . _ M _ _ _ _ . 7 5 A - -	29.5	80A
65	21.59	106	3.41	5037	2 2 .		
57	24.53	120	3.06	5165	2 5 .		
51	27.86	137	2.74	5302	2 8 .		
46	30.68	151	2.48	5394	3 2 .		
40	35.30	173	2.26	5518	3 6 .		
37	38.37	188	1.97	5586	4 0 .		
31	46.07	225	1.74	5718	5 0 .		
26	55.28	271	1.43	5814	5 6 .		
23	62.29	304	1.19	5860	6 3 .		
19	72.41	353	0.89	5870	7 1 .		
38	36.87	181	3.79	7590	F 0 5 2 2 3 6 . _ M _ _ _ _ . 7 5 A - -	37.5	80A
32	43.47	213	3.29	7840	4 0 .		
30	47.60	233	3.05	7969	5 0 .		
24	58.34	284	1.91	8233	5 6 .		
22	65.02	316	1.52	8358	6 3 .		
19	72.92	355	1.02	8464	7 1 .		
18	78.84	382	1.39	8558	F 0 5 3 2 8 0 . _ M _ _ _ _ . 7 5 A - -	38.5	80A
16	86.82	421	1.23	8611	9 0 .		
14	99.86	484	1.13	8670	1 0 0		
13	108.57	526	1.07	8700	1 1 2		
11	130.34	631	0.96	9200	1 2 5		
9.0	156.40	756	0.86	9200	1 6 0		
8.0	176.23	851	0.80	9200	1 8 0		
30	47.40	233	3.82	11300	F 0 6 2 2 5 0 . _ M _ _ _ _ . 7 5 A - -	52.5	80A
25	55.89	275	3.24	11800	5 6 .		
23	61.20	300	2.97	12050	6 3 .		
19	75.00	366	1.91	12603	7 1 .		
17	83.59	408	1.52	12889	9 0 .		
15	93.75	457	1.02	13214	1 0 0		
14	101.36	491	1.39	13433	F 0 6 3 2 1 0 0 . _ M _ _ _ _ . 7 5 A - -	53.5	80A
13	111.62	542	1.23	13682	1 1 2		
11	128.39	623	1.13	14000	1 2 5		
10	139.58	678	1.07	14000	1 6 0		
8.4	167.56	812	0.96	14000	1 8 0		
7.0	201.07	973	0.86	14000	2 0 0		
6.2	226.56	1095	0.80	14000	2 2 5		
13	108.56	525	2.36	17000	F 0 7 3 2 1 0 0 . _ M _ _ _ _ . 7 5 A - -	78.5	80A
12	115.70	563	2.11	17000	1 1 2		
10	137.12	666	1.91	17000	1 2 5		
10	146.40	711	1.83	17000	1 6 0		
7.8	181.67	883	1.61	17000	1 8 0		
6.6	214.23	1039	1.45	17000	2 0 0		
6.0	234.58	1142	1.37	17000	2 2 5		
4.9	287.49	1391	1.22	17000	2 8 0		
4.4	320.43	1551	1.17	17000	3 1 5		
3.9	359.36	1737	1.02	17000	3 6 0		
3.5	404.11	1936	0.82	17000	F 0 7 4 2 4 0 0 . _ M _ _ _ _ . 7 5 A - -	84.5	80A
7.3	193.39	937	3.62	19700	F 0 8 3 2 1 8 0 . _ M _ _ _ _ . 7 5 A - -	126.5	80A
6.3	225.53	1089	3.11	19700	2 2 5		
5.7	247.74	1199	2.83	19700	2 5 0		
4.6	303.60	1473	2.32	19700	2 8 0		
4.3	331.53	1607	2.15	19700	3 1 5		
3.7	381.76	1844	1.92	19700	3 6 0		

NOTE
Other output speeds are available using 2 and 8 pole motors - Please contact our Application Engineers

SERIES F

SELECTION TABLES

GEARED MOTORS

0.75 kW

4 POLE

N2 R/MIN	i	M2 Nm	Fm	N	Unit Designation	Kg	
Output Speed	Ratio	Output Torque	Service Factor	Overhung Load	Column Entry [1] Through [20] Spaces to be filled when entering order	Weight of base mount unit	Motor Sizes
3.6	395.81	1897	1.42	19700	F 0 8 4 2 4 0 0 _ M _ _ _ _ . 7 5 A - -	147	80A
3.1	460.35	2206	1.22	19700	4 5 0		
2.9	490.05	2348	1.18	19700	5 0 0		
2.5	569.96	2731	1.01	19700	5 6 0		
2.2	637.69	3056	0.91	19700	6 3 0		
2.1	679.67	3257	0.85	19700	7 0 0		
1.8	805.50	3860	0.72	19700	8 0 0		
1.6	909.51	4358	0.73	19700	9 0 0		
1.4	1017.59	4876	0.66	19700	1 0 C		
1.3	1084.58	5197	0.62	19700	1 1 C		
1.2	1191.37	5709	0.56	19700	1 2 C		
1.0	1411.94	6766	0.47	19700	1 4 C		
0.9	1594.33	7640	0.42	19700	1 6 C		
3.6	395.66	1896	2.23	32000	F 0 9 4 1 4 0 0 _ M _ _ _ _ . 7 5 A - -	212	80A
3.1	460.18	2205	1.92	32000	4 5 0		
2.8	510.96	2448	1.73	32000	5 0 0		
2.4	594.29	2848	1.49	32000	5 6 0		
2.1	664.91	3186	1.33	32000	6 3 0		
2.0	708.68	3396	1.25	32000	7 0 0		
1.7	839.89	4025	1.05	32000	8 0 0		
1.5	926.74	4441	0.95	32000	9 0 0		
1.4	1036.86	4968	0.85	32000	1 0 C		
1.3	1105.12	5296	0.80	32000	1 1 C		
1.2	1177.20	5641	0.75	32000	1 2 C		
1.0	1395.15	6685	0.63	32000	1 4 C		
0.9	1520.27	7285	0.58	32000	1 6 C		
3.5	400.73	1920	3.78	43000	F 1 0 4 1 4 0 0 _ M _ _ _ _ . 7 5 A - -	301	80A
3.2	445.30	2134	3.40	43000	4 5 0		
2.9	489.83	2347	3.09	43000	5 0 0		
2.5	562.85	2697	2.69	43000	5 6 0		
2.2	638.26	3058	2.37	43000	6 3 0		
2.0	703.99	3373	2.15	43000	7 0 0		
1.8	806.22	3863	1.88	43000	8 0 0		
1.5	924.82	4432	1.64	43000	9 0 0		
1.4	1048.72	5025	1.44	43000	1 0 C		
1.2	1156.73	5543	1.31	43000	1 1 C		
1.1	1324.70	6348	1.14	43000	1 2 C		
0.9	1497.76	7177	1.01	43000	1 4 C		
0.9	1564.43	7496	0.97	43000	1 6 C		
0.8	1791.60	8585	0.84	43000	1 8 C		

0.75 kW

6 POLE

158	5.90	44	1.55	1615	F 0 2 2 2 6 . 3 _ M _ _ _ _ . 7 5 C - -	25	90S
117	7.97	59	1.33	1802	7 . 1		
102	9.07	68	1.23	1895	9 . 0		
90	10.27	77	1.14	1983	1 0 .		
70	13.14	99	0.98	2174	1 2 .		
65	14.16	107	0.94	2234	1 4 .		
51	17.88	136	0.81	2440	1 6 .		
67	13.96	104	3.23	5010	F 0 3 2 2 1 4 . _ M _ _ _ _ . 7 5 C - -	32	90S
59	15.86	118	2.98	5139	1 6 .		
48	19.46	145	2.61	5344	2 0 .		
43	21.59	160	2.36	5445	2 2 .		
38	24.53	183	2.11	5555	2 5 .		
33	27.86	207	1.81	5655	2 8 .		
30	30.68	227	1.64	5715	3 2 .		
26	35.30	262	1.50	5794	3 6 .		
24	38.37	284	1.30	5828	4 0 .		
20	46.07	342	1.14	5860	5 0 .		
17	55.28	410	0.94	5840	5 6 .		
15	62.29	461	0.82	5780	6 3 .		
67	13.96	104	3.23	5010	F 0 4 2 2 1 4 . _ M _ _ _ _ . 7 5 C - -	33	90S
59	15.86	118	2.98	5139	1 6 .		
48	19.46	145	2.61	5344	2 0 .		
43	21.59	160	2.36	5445	2 2 .		
38	24.53	183	2.11	5555	2 5 .		
33	27.86	207	1.81	5655	2 8 .		
30	30.68	227	1.64	5715	3 2 .		
26	35.30	262	1.50	5794	3 6 .		
24	38.37	284	1.30	5828	4 0 .		
20	46.07	342	1.14	5860	5 0 .		
17	55.28	410	0.94	5840	5 6 .		
15	62.29	461	0.82	5780	6 3 .		
40	23.48	175	3.90	7530	F 0 5 2 2 2 5 . _ M _ _ _ _ . 7 5 C - -	41	90S
33	27.83	208	3.35	7790	2 8 .		
31	29.71	221	3.15	7880	3 2 .		
25	36.87	274	2.58	8171	3 6 .		
21	43.47	324	2.21	8354	4 0 .		
20	47.60	355	2.03	8443	5 0 .		
16	58.34	433	1.30	8581	5 6 .		
14	65.02	482	1.04	8640	6 3 .		

NOTE
Other output speeds are available using 2 and 8 pole motors - Please contact our Application Engineers

SERIES F

SELECTION TABLES

GEARED MOTORS

0.75 kW

6 POLE

N2 R/MIN	i	M2 Nm	Fm	N	Unit Designation	Kg	Motor Sizes
Output Speed	Ratio	Output Torque	Service Factor	Overhung Load	Column Entry [1] Through [20] Spaces to be filled when entering order	Weight of base mount unit	
12	78.84	580	1.06	8680	F 0 5 3 2 8 0 . _ M _ _ _ _ . 7 5 C - -	42	90S
11	86.82	639	0.95	8630	9 0 .		
9.3	99.86	735	0.87	8510	1 0 0		
8.6	108.57	798	0.83	8400	1 1 2		
31	30.18	225	3.95	11200	F 0 6 2 2 3 2 . _ M _ _ _ _ . 7 5 C - -	55	90S
26	35.77	267	3.32	11700	3 6 .		
24	38.19	285	3.11	11900	4 0 .		
20	47.40	354	2.52	12449	5 0 .		
17	55.89	416	2.14	12947	5 6 .		
15	61.20	454	1.96	13154	6 3 .		
12	75.00	558	1.30	13713	7 1 .		
11	83.59	621	1.04	13900	9 0 .		
9.2	101.36	747	1.06	14000	F 0 6 3 2 1 0 0 _ M _ _ _ _ . 7 5 C - -	56	90S
8.3	111.62	823	0.95	14000	1 1 2		
7.2	128.39	947	0.87	14000	1 2 5		
6.7	139.58	1029	0.83	14000	1 6 0		
14	64.77	481	3.76	17000	F 0 7 2 2 6 3 . _ M _ _ _ _ . 7 5 C - -	77	90S
12	77.72	578	2.85	17000	7 1 .		
10	89.42	661	1.95	17000	9 0 .		
9.4	99.36	734	1.50	17000	1 0 0		
8.6	108.56	802	1.78	17000	F 0 7 3 2 1 0 0 _ M _ _ _ _ . 7 5 C - -	82	90S
8.0	115.70	854	1.61	17000	1 1 2		
6.8	137.12	1007	1.46	17000	1 2 5		
6.4	146.40	1072	1.41	17000	1 6 0		
5.1	181.67	1336	1.23	17000	1 8 0		
4.3	214.23	1580	1.12	17000	2 0 0		
4.0	234.58	1723	1.06	17000	2 2 5		
3.2	287.49	2113	0.94	17000	2 8 0		
2.9	320.43	2352	0.89	17000	3 1 5		
8.8	105.59	782	3.73	19700	F 0 8 2 2 1 0 0 _ M _ _ _ _ . 7 5 C - -	127	90S
7.4	124.92	920	3.68	19700	F 0 8 3 2 1 1 2 _ M _ _ _ _ . 7 5 C - -	129	90S
6.6	141.33	1041	3.25	19700	1 2 5		
5.8	159.53	1176	2.88	19700	1 6 0		
4.8	193.39	1418	2.39	19700	1 8 0		
4.1	225.53	1663	2.09	19700	2 0 0		
3.8	247.74	1821	1.94	19700	2 2 5		
3.1	303.60	2229	1.61	19700	2 8 0		
2.8	331.53	2444	1.47	19700	3 1 5		
2.4	381.76	2801	1.29	19700	3 6 0		
2.3	395.81	2927	0.92	19000	F 0 8 4 2 4 0 0 _ M _ _ _ _ . 7 5 C - -	149	90S
2.0	460.35	3405	0.80	19000	4 5 0		
6.3	147.03	1083	3.98	29900	F 0 9 3 1 1 4 0 _ M _ _ _ _ . 7 5 C - -	189	90S
5.8	160.82	1185	3.58	29900	1 6 0		
5.2	177.54	1313	3.23	29900	1 8 0		
4.5	207.69	1530	2.82	29877	2 0 0		
4.1	229.28	1685	2.56	29865	2 2 5		
3.8	244.23	1803	2.35	29865	2 5 0		
3.4	274.63	2013	2.11	29878	2 8 0		
2.9	315.41	2317	1.86	29832	3 1 5		
2.6	354.67	2606	1.65	29799	3 6 0		
2.3	395.66	2926	1.45	32000	F 0 9 4 1 4 0 0 _ M _ _ _ _ . 7 5 C - -	215	90S
2.0	460.18	3404	1.24	32000	4 5 0		
1.8	510.96	3779	1.12	32000	5 0 0		
1.5	594.29	4395	0.96	32000	5 6 0		
1.4	664.91	4918	0.86	32000	6 3 0		
1.3	708.68	5241	0.81	32000	7 0 0		
3.6	253.86	1910	3.35	43000	F 1 0 3 1 2 5 0 _ M _ _ _ _ . 7 5 C - -	294	90S
3.3	272.75	2050	3.12	43000	2 8 0		
2.8	319.79	2400	3.02	43000	3 1 5		
2.6	343.57	2572	2.82	43000	3 6 0		
2.3	400.73	2964	2.45	43000	F 1 0 4 1 4 0 0 _ M _ _ _ _ . 7 5 C - -	304	90S
2.1	445.30	3293	2.20	43000	4 5 0		
1.9	489.83	3623	2.00	43000	5 0 0		
1.6	562.85	4163	1.74	43000	5 6 0		
1.4	638.26	4721	1.54	43000	6 3 0		
1.3	703.99	5207	1.39	43000	7 0 0		
1.1	806.22	5963	1.22	43000	8 0 0		
1.0	924.82	6840	1.06	43000	9 0 0		
0.9	1048.72	7756	0.93	43000	1 0 C		
0.8	1156.73	8555	0.85	43000	1 1 C		

NOTE
Other output speeds are available using 2 and 8 pole motors - Please contact our Application Engineers

SERIES F

SELECTION TABLES

GEARED MOTORS

1.1 kW

4 POLE

N2 R/MIN	i	M2 Nm	Fm	N	Unit Designation	Kg	Motor Sizes
Output Speed	Ratio	Output Torque	Service Factor	Overhung Load	Column Entry <input type="checkbox"/> 1 Through <input type="checkbox"/> 20 Spaces to be filled when entering order	Weight of base mount unit	
239	5.90	43	1.43	1389	F 0 2 2 2 6 . 3 _ M _ _ _ _ 1 . 1 A - -	25	90S
177	7.97	58	1.24	1550	7 . 1		
155	9.07	66	1.16	1626	9 . 0		
137	10.27	74	1.08	1701	1 0 .		
107	13.14	95	0.94	1862	1 2 .		
98	14.16	104	0.88	1923	1 4 .		
101	13.96	100	3.34	4279	F 0 3 2 2 1 4 . _ M _ _ _ _ 1 . 1 A - -	32	90S
89	15.86	114	3.01	4382	1 6 .		
72	19.46	140	2.54	4539	2 0 .		
65	21.59	155	2.32	4613	2 2 .		
57	24.53	177	2.09	4685	2 5 .		
51	27.86	201	1.87	4758	2 8 .		
46	30.68	221	1.69	4792	3 2 .		
40	35.30	254	1.54	4828	3 6 .		
37	38.37	276	1.34	4836	4 0 .		
31	46.07	330	1.18	4823	5 0 .		
26	55.28	397	0.97	4740	5 6 .		
23	62.29	446	0.81	4650	6 3 .		
101	13.96	100	3.34	4279	F 0 4 2 2 1 4 . _ M _ _ _ _ 1 . 1 A - -	33	90S
89	15.86	114	3.01	4382	1 6 .		
72	19.46	140	2.54	4539	2 0 .		
65	21.59	155	2.32	4613	2 2 .		
57	24.53	177	2.09	4685	2 5 .		
51	27.86	201	1.87	4758	2 8 .		
46	30.68	221	1.69	4792	3 2 .		
40	35.30	254	1.54	4828	3 6 .		
37	38.37	276	1.34	4836	4 0 .		
31	46.07	330	1.18	4823	5 0 .		
26	55.28	397	0.97	4740	5 6 .		
23	62.29	446	0.81	4650	6 3 .		
60	23.48	169	3.80	6420	F 0 5 2 2 2 5 . _ M _ _ _ _ 1 . 1 A - -	41	90S
51	27.83	200	3.29	6624	2 8 .		
47	29.71	214	3.11	6690	3 2 .		
38	36.87	266	2.58	6896	3 6 .		
32	43.47	313	2.25	7023	4 0 .		
30	47.60	342	2.08	7075	5 0 .		
24	58.34	417	1.30	7141	5 6 .		
22	65.02	464	1.03	7141	6 3 .		
18	78.84	560	0.95	7200	F 0 5 3 2 8 0 . _ M _ _ _ _ 1 . 1 A - -	42	90S
16	86.82	617	0.84	7220	9 0 .		
39	35.77	258	3.43	10000	F 0 6 2 2 3 6 . _ M _ _ _ _ 1 . 1 A - -	55	90S
37	38.19	275	3.23	10178	4 0 .		
30	47.40	342	2.61	10659	5 0 .		
25	55.89	403	2.21	11040	5 6 .		
23	61.20	440	2.02	11221	6 3 .		
19	75.00	537	1.30	11593	7 1 .		
17	83.59	598	1.03	11300	9 0 .		
14	101.36	721	0.95	11300	F 0 6 3 2 1 0 0 _ M _ _ _ _ 1 . 1 A - -	56	90S
13	111.62	795	0.84	11300	1 1 2		
24	59.14	426	3.85	15300	F 0 7 2 2 5 6 . _ M _ _ _ _ 1 . 1 A - -	77	90S
22	64.77	467	3.55	15588	6 3 .		
18	77.72	556	2.86	16227	7 1 .		
16	89.42	644	1.97	16797	9 0 .		
14	99.36	711	1.55	17000	1 0 0		
13	108.56	770	1.61	17000	F 0 7 3 2 1 0 0 _ M _ _ _ _ 1 . 1 A - -	82	90S
12	115.70	825	1.44	17000	1 1 2		
10	137.12	977	1.30	17000	1 2 5		
10	146.40	1042	1.25	17000	1 6 0		
7.8	181.67	1295	1.10	17000	1 8 0		
6.6	214.23	1525	0.99	17000	2 0 0		
6.0	234.58	1675	0.94	17000	2 2 5		
4.9	287.49	2041	0.83	17000	2 8 0		
13	105.59	755	3.56	19700	F 0 8 2 2 1 0 0 _ M _ _ _ _ 1 . 1 A - -	127	90S
11	124.92	889	3.81	19700	F 0 8 3 2 1 1 2 _ M _ _ _ _ 1 . 1 A - -	129	90S
10	141.33	1006	3.37	19700	1 2 5		
8.8	159.53	1134	2.99	19700	1 6 0		
7.3	193.39	1374	2.47	19700	1 8 0		
6.3	225.53	1597	2.12	19700	2 0 0		
5.7	247.74	1759	1.93	19700	2 2 5		
4.6	303.60	2161	1.58	19700	2 8 0		
4.3	331.53	2357	1.47	19700	3 1 5		
3.7	381.76	2705	1.31	19700	3 6 0		
3.6	395.81	2782	0.97	19700	F 0 8 4 2 4 0 0 _ M _ _ _ _ 1 . 1 A - -	149	90S
3.1	460.35	3235	0.83	19700	4 5 0		
2.9	490.05	3444	0.80	19700	5 0 0		

NOTE

Other output speeds are available using 2 and 8 pole motors - Please contact our Application Engineers

SERIES F

SELECTION TABLES

GEARED MOTORS

1.1 kW

N2 R/MIN	i	M2 Nm	Fm	N	Unit Designation	Kg	
Output Speed	Ratio	Output Torque	Service Factor	Overhung Load	Column Entry 1 Through 20 Spaces to be filled when entering order	Weight of base mount unit	Motor Sizes
8.8	160.82	1144	3.70	29900	F 0 9 3 1 1 6 0 _ M _ _ _ _ 1 . 1 A - -	189	90S
7.9	177.54	1265	3.35	29890	1 8 0		
6.8	207.69	1472	2.93	29885	2 0 0		
6.1	229.28	1630	2.64	29868	2 2 5		
5.8	244.23	1737	2.44	29868	2 5 0		
5.1	274.63	1949	2.17	29853	2 8 0		
4.5	315.41	2236	1.93	29832	3 1 5		
4.0	354.67	2513	1.71	29810	3 6 0		
3.6	395.66	2781	1.52	32000	F 0 9 4 1 4 0 0 _ M _ _ _ _ 1 . 1 A - -	215	90S
3.1	460.18	3234	1.31	32000	4 5 0		
2.8	510.96	3591	1.18	32000	5 0 0		
2.4	594.29	4177	1.01	32000	5 6 0		
2.1	664.91	4673	0.91	32000	6 3 0		
2.0	708.68	4981	0.85	32000	7 0 0		
5.4	253.86	1849	3.46	43000	F 1 0 3 1 2 5 0 _ M _ _ _ _ 1 . 1 A - -	294	90S
5.1	272.75	1963	3.23	43000	2 8 0		
4.3	319.79	2321	3.12	43000	3 1 5		
4.0	343.57	2486	2.92	43000	3 6 0		
3.5	400.73	2816	2.57	43000	F 1 0 4 1 4 0 0 _ M _ _ _ _ 1 . 1 A - -	304	90S
3.2	445.30	3130	2.32	43000	4 5 0		
2.9	489.83	3442	2.11	43000	5 0 0		
2.5	562.85	3956	1.83	43000	5 6 0		
2.2	638.26	4486	1.62	43000	6 3 0		
2.0	703.99	4948	1.47	43000	7 0 0		
1.8	806.22	5666	1.28	43000	8 0 0		
1.5	924.82	6500	1.12	43000	9 0 0		
1.4	1048.72	7370	0.98	43000	1 0 C		
1.2	1156.73	8129	0.89	43000	1 1 C		

1.1 kW

6 POLE

158	5.90	64	1.05	1796	F 0 2 2 2 6 . 3 _ M _ _ _ _ 1 . 1 C - -	28	90L
117	7.97	87	0.91	1802	7 . 1		
102	9.07	100	0.84	1895	9 . 0		
106	8.78	96	3.31	4228	F 0 3 2 2 9 . 0 _ M _ _ _ _ 1 . 1 C - -	35	90L
96	9.68	106	3.08	4313	1 0 .		
85	10.99	120	2.73	4417	1 2 .		
67	13.96	153	2.20	4596	1 4 .		
59	15.86	174	2.03	4668	1 6 .		
48	19.46	213	1.78	4769	2 0 .		
43	21.59	235	1.61	4805	2 2 .		
38	24.53	268	1.44	4832	2 5 .		
33	27.86	304	1.23	4830	2 8 .		
30	30.68	334	1.12	4808	3 2 .		
26	35.30	384	1.02	4754	3 6 .		
24	38.37	417	0.89	4700	4 0 .		
106	8.78	96	3.31	4228	F 0 4 2 2 9 . 0 _ M _ _ _ _ 1 . 1 C - -	36	90L
96	9.68	106	3.08	4313	1 0 .		
85	10.99	120	2.73	4417	1 2 .		
67	13.96	153	2.20	4596	1 4 .		
59	15.86	174	2.03	4668	1 6 .		
48	19.46	213	1.78	4769	2 0 .		
43	21.59	235	1.61	4805	2 2 .		
38	24.53	268	1.44	4832	2 5 .		
33	27.86	304	1.23	4830	2 8 .		
30	30.68	334	1.12	4808	3 2 .		
26	35.30	384	1.02	4754	3 6 .		
24	38.37	417	0.89	4700	4 0 .		
63	14.70	161	3.97	6350	F 0 5 2 2 1 4 . _ M _ _ _ _ 1 . 1 C - -	44	90L
55	16.93	185	3.10	6520	1 6 .		
47	19.69	215	3.01	6687	2 0 .		
42	22.03	240	2.81	6802	2 2 .		
40	23.48	256	2.66	6859	2 5 .		
33	27.83	305	2.28	6996	2 8 .		
31	29.71	325	2.15	7034	3 2 .		
25	36.87	402	1.76	7123	3 6 .		
21	43.47	475	1.51	7120	4 0 .		
20	47.60	520	1.38	7093	5 0 .		
16	58.34	636	0.89	6938	5 6 .		
43	21.76	239	3.10	9820	F 0 6 2 2 2 2 . _ M _ _ _ _ 1 . 1 C - -	58	90L
37	25.31	277	3.01	10200	2 5 .		
33	28.32	310	2.84	10400	2 8 .		
31	30.18	330	2.69	10580	3 2 .		
26	35.77	391	2.26	10964	3 6 .		
24	38.19	419	2.12	11112	4 0 .		
20	47.40	519	1.72	11300	5 0 .		
17	55.89	610	1.46	11300	5 6 .		
15	61.20	667	1.34	11300	6 3 .		
12	75.00	819	0.89	11300	7 1 .		

NOTE

Other output speeds are available using 2 and 8 pole motors - Please contact our Application Engineers

SERIES F

SELECTION TABLES

GEARED MOTORS

1.1 kW

6 POLE

N2 R/MIN	i	M2 Nm	Fm	N	Unit Designation	Kg	Motor Sizes
Output Speed	Ratio	Output Torque	Service Factor	Overhung Load	Column Entry [1] Through [20] Spaces to be filled when entering order	Weight of base mount unit	
22	42.77	468	3.61	15600	F 0 7 2 2 4 0 . _ M _ _ _ _ 1 . 1 C - -	80	90L
19	49.59	541	3.20	16100	5 0 .		
16	59.14	645	2.77	16787	5 6 .		
14	64.77	706	2.56	17000	6 3 .		
12	77.72	847	1.95	17000	7 1 .		
10	89.42	970	1.33	17000	9 0 .		
9.4	99.36	1076	1.02	17000	1 0 0		
8.6	108.56	1176	1.22	17000	F 0 7 3 2 1 0 0 _ M _ _ _ _ 1 . 1 C - -	85	90L
8.0	115.70	1253	1.10	17000	1 1 2		
6.8	137.12	1477	1.00	17000	1 2 5		
6.4	146.40	1573	0.96	17000	1 6 0		
5.1	181.67	1959	0.84	17000	1 8 0		
11	83.97	918	3.36	19700	F 0 8 2 2 7 1 . _ M _ _ _ _ 1 . 1 C - -	130	90L
10	91.70	1000	3.12	19700	9 0 .		
8.8	105.59	1147	2.55	19700	1 0 0		
8.1	114.15	1233	2.75	19700	F 0 8 3 2 1 0 0 _ M _ _ _ _ 1 . 1 C - -	132	90L
7.4	124.92	1350	2.51	19700	1 1 2		
6.6	141.33	1527	2.22	19700	1 2 5		
5.8	159.53	1726	1.96	19700	1 6 0		
4.8	193.39	2080	1.63	19700	1 8 0		
4.1	225.53	2439	1.43	19700	2 0 0		
3.8	247.74	2672	1.32	19700	2 5 0		
3.1	303.60	3270	1.10	19700	2 8 0		
2.8	331.53	3585	1.00	19700	3 1 5		
2.4	381.76	4108	0.88	19700	3 6 0		
9.1	102.48	1111	3.81	29900	F 0 9 3 1 1 0 0 _ M _ _ _ _ 1 . 1 C - -	192	90L
8.2	113.85	1234	3.43	29900	1 1 2		
7.0	132.34	1430	3.01	29900	1 2 5		
6.3	147.03	1588	2.71	29870	1 4 0		
5.8	160.82	1738	2.44	29870	1 6 0		
5.2	177.54	1925	2.20	29855	1 8 0		
4.5	207.69	2244	1.92	29837	2 0 0		
4.1	229.28	2471	1.74	29805	2 2 5		
3.8	244.23	2645	1.60	29805	2 5 0		
3.4	274.63	2953	1.44	29842	2 8 0		
2.9	315.41	3398	1.27	29770	3 1 5		
2.6	354.67	3823	1.13	29706	3 6 0		
2.3	395.66	4292	0.99	32000	F 0 9 4 1 4 0 0 _ M _ _ _ _ 1 . 1 C - -	218	90L
2.0	460.18	4992	0.85	32000	4 5 0		
5.6	162.91	1787	3.58	43400	F 1 0 3 1 1 6 0 _ M _ _ _ _ 1 . 1 C - -	298	90L
4.9	187.70	2057	3.11	43400	1 8 0		
4.5	205.21	2243	3.23	43400	2 0 0		
3.9	236.45	2576	2.81	43400	2 2 5		
3.6	253.86	2772	2.32	43400	2 5 0		
3.4	272.75	2974	2.15	43400	2 8 0		
2.9	319.79	3481	2.08	43390	3 1 5		
2.7	343.57	3731	1.94	43380	3 6 0		
2.3	395.66	4292	1.69	43000	F 1 0 4 1 4 0 0 _ M _ _ _ _ 1 . 1 C - -	307	90L
2.0	460.18	4992	1.45	43000	4 5 0		
1.8	510.96	5543	1.31	43000	5 0 0		
1.5	594.29	6447	1.09	43000	5 6 0		
1.4	664.91	7213	1.01	43000	6 3 0		
1.3	708.68	7687	0.94	43000	7 0 0		
1.1	839.89	9111	0.80	43000	8 0 0		

1.5 kW

4 POLE

241	5.90	58	1.06	1384	F 0 2 2 2 6 . 3 _ M _ _ _ _ 1 . 5 A - -	28	90L
177	7.97	79	0.91	1550	7 . 1		
155	9.07	90	0.85	1626	9 . 0		
137	10.27	101	0.80	1701	1 0 .		
162	8.78	85	3.66	3663	F 0 3 2 2 9 . 0 _ M _ _ _ _ 1 . 5 A - -	35	90L
147	9.68	94	3.37	3734	1 0 .		
129	10.99	107	3.04	3823	1 2 .		
102	13.96	136	2.47	3966	1 4 .		
90	15.86	154	2.23	4028	1 6 .		
73	19.46	190	1.87	4103	2 0 .		
66	21.59	210	1.72	4129	2 2 .		
58	24.53	240	1.54	4137	2 5 .		
51	27.86	272	1.38	4135	2 8 .		
46	30.68	299	1.25	4105	3 2 .		
40	35.30	344	1.14	4040	3 6 .		
37	38.37	373	0.99	3980	4 0 .		
31	46.07	446	0.87	3800	5 0 .		

NOTE

Other output speeds are available using 2 and 8 pole motors - Please contact our Application Engineers

SERIES F

SELECTION TABLES

GEARED MOTORS

1.5 kW

N2 R/MIN	i	M2 Nm	Fm	N	Unit Designation	Kg	Motor Sizes
Output Speed	Ratio	Output Torque	Service Factor	Overhung Load	Column Entry [1] Through [20] Spaces to be filled when entering order	Weight of base mount unit	
162	8.78	85	3.66	3663	F 0 4 2 2 9 . 0 _ M _ _ _ _ _ 1 . 5 A - -	36	90L
147	9.68	94	3.37	3734	1 0 .		
129	10.99	107	3.04	3823	1 2 .		
102	13.96	136	2.47	3966	1 4 .		
90	15.86	154	2.23	4028	1 6 .		
73	19.46	190	1.87	4103	2 0 .		
66	21.59	210	1.72	4129	2 2 .		
58	24.53	240	1.54	4137	2 5 .		
51	27.86	272	1.38	4135	2 8 .		
46	30.68	299	1.25	4105	3 2 .		
40	35.30	344	1.14	4040	3 6 .		
37	38.37	373	0.99	3980	4 0 .		
31	46.07	446	0.87	3800	5 0 .		
84	16.93	165	3.47	5640	F 0 5 2 2 1 6 . _ M _ _ _ _ _ 1 . 5 A - -	44	90L
72	19.69	192	3.26	5780	2 0 .		
64	22.03	215	2.97	5874	2 2 .		
60	23.48	229	2.81	5913	2 5 .		
51	27.83	271	2.43	6024	2 8 .		
48	29.71	290	2.30	6050	3 2 .		
39	36.87	360	1.91	6103	3 6 .		
33	43.47	423	1.66	6090	4 0 .		
30	47.60	464	1.53	6053	5 0 .		
24	58.34	565	0.96	5892	5 6 .		
65	21.76	213	3.47	8520	F 0 6 2 2 2 2 . _ M _ _ _ _ _ 1 . 5 A - -	58	90L
56	25.31	248	3.37	8820	2 5 .		
50	28.32	277	3.17	9040	2 8 .		
47	30.18	296	3.01	9152	3 2 .		
40	35.77	350	2.53	9449	3 6 .		
37	38.19	373	2.38	9586	4 0 .		
30	47.40	463	1.93	9926	5 0 .		
25	55.89	546	1.63	10173	5 6 .		
23	61.20	596	1.50	10274	6 3 .		
19	75.00	728	0.96	10439	7 1 .		
33	42.77	419	3.70	13500	F 0 7 2 2 4 0 . _ M _ _ _ _ _ 1 . 5 A - -	80	90L
29	49.59	483	3.27	14000	5 0 .		
24	59.14	577	2.84	14533	5 6 .		
22	64.77	632	2.62	14756	6 3 .		
18	77.72	753	2.11	15234	7 1 .		
16	89.42	872	1.46	15631	9 0 .		
14	99.36	962	1.14	15851	1 0 0		
13	108.56	1043	1.19	16088	F 0 7 3 2 1 0 0 _ M _ _ _ _ _ 1 . 5 A - -	85	90L
12	115.70	1118	1.06	16192	1 1 2		
10	137.12	1323	0.96	16400	1 2 5		
10	146.40	1412	0.92	16500	1 6 0		
7.8	181.67	1754	0.81	16600	1 8 0		
17	83.97	820	3.50	19700	F 0 8 2 2 7 1 . _ M _ _ _ _ _ 1 . 5 A - -	130	90L
15	91.70	894	3.23	19700	9 0 .		
13	105.59	1022	2.63	19700	1 0 0		
12	114.15	1100	3.08	19700	F 0 8 3 2 1 0 0 _ M _ _ _ _ _ 1 . 5 A - -	132	90L
11	124.92	1204	2.81	19700	1 1 2		
10	141.33	1362	2.49	19700	1 2 5		
8.9	159.53	1536	2.21	19700	1 6 0		
7.3	193.39	1861	1.82	19700	1 8 0		
6.3	225.53	2163	1.57	19700	2 0 0		
5.7	247.74	2381	1.42	19700	2 2 5		
4.7	303.60	2926	1.17	19700	2 8 0		
4.3	331.53	3192	1.08	19700	3 1 5		
3.7	381.76	3663	0.97	19700	3 6 0		
12	113.85	1100	3.85	29900	F 0 9 3 1 1 1 2 _ M _ _ _ _ _ 1 . 5 A - -	192	90L
11	132.34	1274	3.38	29900	1 2 5		
10	147.03	1416	3.04	29873	1 4 0		
8.8	160.82	1549	2.74	29873	1 6 0		
8.0	177.54	1713	2.47	29865	1 8 0		
6.8	207.69	1994	2.16	29847	2 0 0		
6.2	229.28	2207	1.95	29833	2 2 5		
5.8	244.23	2353	1.80	29833	2 5 0		
5.2	274.63	2639	1.61	29800	2 8 0		
4.5	315.41	3028	1.42	29783	3 1 5		
4.0	354.67	3402	1.27	29744	3 6 0		
3.6	395.66	3792	1.12	32000	F 0 9 4 1 4 0 0 _ M _ _ _ _ _ 1 . 5 A - -	218	90L
3.1	460.18	4410	0.96	32000	4 5 0		
2.8	510.96	4897	0.86	32000	5 0 0		
8.5	162.91	1610	3.98	43000	F 1 0 3 1 1 6 0 _ M _ _ _ _ _ 1 . 5 A - -	298	90L
7.4	187.70	1854	3.45	43000	1 8 0		
6.8	205.21	2018	3.59	43000	2 0 0		
5.9	236.45	2324	3.12	43000	2 2 5		
5.5	253.86	2503	2.56	43000	2 5 0		
5.1	272.75	2684	2.38	43000	2 8 0		
4.3	319.79	3142	2.31	43000	3 1 5		
4.0	343.57	3366	2.15	43000	3 6 0		

NOTE
Other output speeds are available using 2 and 8 pole motors - Please contact our Application Engineers

SERIES F

SELECTION TABLES

GEARED MOTORS

1.5 kW

4 POLE

1.5 kW

6 POLE

N2 R/MIN	i	M2 Nm	Fm	N	Unit Designation	Kg	Motor Sizes		
Output Speed	Ratio	Output Torque	Service Factor	Overhung Load	Column Entry [1] Through [20] Spaces to be filled when entering order	Weight of base mount unit			
3.5	400.73	3840	1.89	43000	F 1 0 4 1 4 0 0 _ M _ _ _ _ 1 . 5 A - -	301	90L		
3.2	445.30	4268	1.70	43000	4 5 0				
2.9	489.83	4694	1.54	43000	5 0 0				
2.5	562.85	5394	1.34	43000	5 6 0				
2.2	638.26	6117	1.19	43000	6 3 0				
2.0	703.99	6747	1.07	43000	7 0 0				
1.8	806.22	7727	0.94	43000	8 0 0				
1.5	924.82	8863	0.82	43000	9 0 0				
149	6.26	94	3.06	3880	F 0 3 2 2 7 . 1 _ M _ _ _ _ 1 . 5 C - -	48	100L		
106	8.78	131	2.43	3958	9 . 0				
96	9.68	145	2.26	4025	1 0 .				
85	10.99	164	2.00	4101	1 2 .				
67	13.96	209	1.62	4220	1 4 .				
59	15.86	237	1.49	4255	1 6 .				
48	19.46	291	1.31	4287	2 0 .				
43	21.59	323	1.18	4283	2 2 .				
38	24.53	367	1.05	4258	2 5 .				
33	27.86	416	0.90	4200	2 8 .				
30	30.68	458	0.82	4133	3 2 .				
149	6.26	94	3.06	3880	F 0 4 2 2 7 . 1 _ M _ _ _ _ 1 . 5 C - -			48	100L
106	8.78	131	2.43	3958	9 . 0				
96	9.68	145	2.26	4025	1 0 .				
85	10.99	164	2.00	4101	1 2 .				
67	13.96	209	1.62	4220	1 4 .				
59	15.86	237	1.49	4255	1 6 .				
48	19.46	291	1.31	4287	2 0 .				
43	21.59	323	1.18	4283	2 2 .				
38	24.53	367	1.05	4258	2 5 .				
33	27.86	416	0.90	4200	2 8 .				
30	30.68	458	0.82	4133	3 2 .				
87	10.87	159	3.85	5610	F 0 5 2 2 1 0 . _ M _ _ _ _ 1 . 5 C - -	54	100L		
77	12.33	180	3.46	5728	1 2 .				
65	14.70	215	2.98	5870	1 4 .				
56	16.93	247	2.32	5968	1 6 .				
48	19.69	288	2.26	6045	2 0 .				
43	22.03	321	2.10	6084	2 2 .				
40	23.48	342	1.99	6093	2 5 .				
34	27.83	407	1.71	6088	2 8 .				
32	29.71	434	1.61	6067	3 2 .				
26	36.87	537	1.32	5925	3 6 .				
22	43.47	634	1.13	5710	4 0 .				
20	47.60	695	1.04	5550	5 0 .				
68	13.98	205	3.93	8460	F 0 6 2 2 1 4 . _ M _ _ _ _ 1 . 5 C - -			68	100L
60	15.85	232	3.54	8704	1 6 .				
50	18.90	277	3.03	9046	2 0 .				
44	21.76	319	2.32	9309	2 2 .				
38	25.31	370	2.26	9602	2 5 .				
34	28.32	414	2.12	9740	2 8 .				
31	30.18	441	2.02	9872	3 2 .				
27	35.77	523	1.70	10123	3 6 .				
25	38.19	559	1.59	10211	4 0 .				
20	47.40	694	1.29	10383	5 0 .				
17	55.89	815	1.10	10500	5 6 .				
16	61.20	890	1.00	10500	6 3 .				
36	26.41	385	3.94	13300	F 0 7 2 2 2 5 . _ M _ _ _ _ 1 . 5 C - -	88	100L		
32	29.95	437	3.65	13706	2 8 .				
29	33.03	484	3.33	13977	3 2 .				
25	37.83	552	3.02	14363	3 6 .				
22	42.77	624	2.70	14762	4 0 .				
19	49.59	722	2.39	15135	5 0 .				
16	59.14	861	2.08	15630	5 6 .				
15	64.77	942	1.92	15838	6 3 .				
12	77.72	1131	1.46	16117	7 1 .				
11	89.42	1294	1.00	16400	9 0 .				
8.8	108.56	1570	0.91	16500	F 0 7 3 2 1 0 0 _ M _ _ _ _ 1 . 5 C - -			93	100L
8.2	115.70	1673	0.82	16500	1 1 2				
18	53.49	782	3.68	19700	F 0 8 2 2 5 0 . _ M _ _ _ _ 1 . 5 C - -			139	100L
15	62.38	910	3.24	19700	5 6 .				
14	68.52	997	3.01	19700	6 3 .				
11	83.97	1226	2.52	19700	7 1 .				
10	91.70	1335	2.34	19700	9 0 .				
9.0	105.59	1531	1.91	19700	1 0 0				
8.3	114.15	1646	2.06	19700	F 0 8 3 2 1 0 0 _ M _ _ _ _ 1 . 5 C - -	141	100L		
7.6	124.92	1802	1.88	19700	1 1 2				
6.7	141.33	2039	1.66	19700	1 2 5				
6.0	159.53	2304	1.47	19700	1 6 0				
4.9	193.39	2777	1.22	19700	1 8 0				
4.2	225.53	3256	1.07	19700	2 0 0				
3.8	247.74	3567	0.99	19700	2 2 5				

NOTE

Other output speeds are available using 2 and 8 pole motors - Please contact our Application Engineers

SERIES F

SELECTION TABLES

GEARED MOTORS

1.5 kW

6 POLE

N2 R/MIN	i	M2 Nm	Fm	N	Unit Designation	Kg	Motor Sizes
Output Speed	Ratio	Output Torque	Service Factor	Overhung Load	Column Entry [1] Through [20] Spaces to be filled when entering order	Weight of base mount unit	
14	67.71	988	4.00	29900	F 0 9 2 1 7 1 . _ M _ _ _ _ _ 1 . 5 C - -	189	100L
12	76.14	1107	3.31	29900	8 0 .		
11	87.44	1273	3.38	29900	9 0 .		
10	98.32	1429	3.01	29900	1 0 0		
9.3	102.48	1484	2.86	29886	F 0 9 3 1 1 0 0 _ M _ _ _ _ _ 1 . 5 C - -	199	100L
8.3	113.85	1647	2.57	29873	1 1 2		
7.2	132.34	1910	2.26	29860	1 2 5		
6.5	147.03	2121	2.03	29836	1 4 0		
5.9	160.82	2320	1.83	29836	1 6 0		
5.4	177.54	2570	1.65	29804	1 8 0		
4.6	207.69	2996	1.44	29791	2 0 0		
4.1	229.28	3299	1.31	29737	2 2 5		
3.9	244.23	3531	1.20	29737	2 5 0		
3.5	274.63	3942	1.08	29800	2 8 0		
3.0	315.41	4536	0.95	29700	3 1 5		
2.7	354.67	5103	0.84	29600	3 6 0		
8.3	114.24	1655	3.87	43400	F 1 0 3 1 1 1 2 _ M _ _ _ _ _ 1 . 5 C - -	302	100L
7.3	129.50	1868	3.88	43400	1 2 5		
6.6	143.90	2077	3.49	43400	1 4 0		
5.8	162.91	2360	2.71	43400	1 6 0		
5.1	187.70	2717	2.36	43400	1 8 0		
4.6	205.21	2962	2.45	43300	2 0 0		
4.0	236.45	3402	2.13	43300	2 2 5		
3.7	253.86	3660	1.75	43300	2 5 0		
3.5	272.75	3927	1.63	43300	2 8 0		
3.0	319.79	4598	1.58	43300	3 1 5		
2.8	343.57	4928	1.47	43300	3 6 0		
2.4	400.73	5681	1.28	43000	F 1 0 4 1 4 0 0 _ M _ _ _ _ _ 1 . 5 C - -	312	100L
2.2	445.30	6312	1.15	43000	4 5 0		
2.0	489.83	6944	1.04	43000	5 0 0		
1.7	562.85	7979	0.91	43000	5 6 0		
1.5	638.26	9048	0.80	43000	6 3 0		

2.2 kW

4 POLE

228	6.26	89	3.20	3280	F 0 3 2 2 7 . 1 _ M _ _ _ _ _ 2 . 2 A - -	48	100L
163	8.78	125	2.51	3405	9 . 0		
148	9.68	138	2.31	3451	1 0 .		
130	10.99	157	2.08	3503	1 2 .		
102	13.96	199	1.69	3563	1 4 .		
90	15.86	226	1.53	3573	1 6 .		
73	19.46	277	1.29	3551	2 0 .		
66	21.59	308	1.18	3521	2 2 .		
58	24.53	350	1.06	3454	2 5 .		
51	27.86	397	0.94	3370	2 8 .		
47	30.68	437	0.86	3276	3 2 .		
228	6.26	89	3.20	3280	F 0 4 2 2 7 . 1 _ M _ _ _ _ _ 2 . 2 A - -	48	100L
163	8.78	125	2.51	3405	9 . 0		
148	9.68	138	2.31	3451	1 0 .		
130	10.99	157	2.08	3503	1 2 .		
102	13.96	199	1.69	3563	1 4 .		
90	15.86	226	1.53	3573	1 6 .		
73	19.46	277	1.29	3551	2 0 .		
66	21.59	308	1.18	3521	2 2 .		
58	24.53	350	1.06	3454	2 5 .		
51	27.86	397	0.94	3370	2 8 .		
47	30.68	437	0.86	3276	3 2 .		
132	10.87	155	3.74	4760	F 0 5 2 2 1 0 . _ M _ _ _ _ _ 2 . 2 A - -	52	100L
116	12.33	176	3.36	4840	1 2 .		
97	14.70	209	2.89	4941	1 4 .		
84	16.93	241	2.38	4999	1 6 .		
73	19.69	280	2.24	5035	2 0 .		
65	22.03	313	2.04	5042	2 2 .		
61	23.48	334	1.93	5026	2 5 .		
51	27.83	395	1.67	4973	2 8 .		
48	29.71	422	1.58	4929	3 2 .		
39	36.87	524	1.31	4715	3 6 .		
33	43.47	617	1.14	4456	4 0 .		
30	47.60	675	1.05	4265	5 0 .		
102	13.98	199	3.65	7250	F 0 6 2 2 1 4 . _ M _ _ _ _ _ 2 . 2 A - -	66	100L
90	15.85	226	3.42	7450	1 6 .		
76	18.90	270	3.10	7722	2 0 .		
66	21.76	311	2.38	7927	2 2 .		
56	25.31	361	2.31	8131	2 5 .		
50	28.32	403	2.18	8271	2 8 .		
47	30.18	431	2.07	8334	3 2 .		
40	35.77	509	1.74	8485	3 6 .		
37	38.19	543	1.64	8550	4 0 .		
30	47.40	674	1.32	8644	5 0 .		
26	55.89	795	1.12	8655	5 6 .		
23	61.20	868	1.03	8616	6 3 .		

NOTE

Other output speeds are available using 2 and 8 pole motors - Please contact our Application Engineers

SERIES F

SELECTION TABLES

GEARED MOTORS

2.2 kW

N2 R/MIN	i	M2 Nm	Fm	N	Unit Designation	Kg			
Output Speed	Ratio	Output Torque	Service Factor	Overhung Load	Column Entry 1 Through 20 Spaces to be filled when entering order	Weight of base mount unit	Motor Sizes		
54	26.41	375	3.70	11400	F 0 7 2 2 2 5 . _ M _ _ _ _ 2 . 2 A - -	86	100L		
48	29.95	425	3.43	11700	2 8 .				
43	33.03	471	3.12	11927	3 2 .				
38	37.83	540	2.83	12247	3 6 .				
33	42.77	610	2.54	12535	4 0 .				
29	49.59	703	2.25	12874	5 0 .				
24	59.14	841	1.95	13191	5 6 .				
22	64.77	921	1.80	13300	6 3 .				
18	77.72	1098	1.45	13496	7 1 .				
16	89.42	1270	1.00	13591	9 0 .				
13	108.56	1519	0.82	13648	F 0 7 3 2 1 0 0 _ M _ _ _ _ 2 . 2 A - -			91	100L
27	53.49	759	3.53	16800	F 0 8 2 2 5 0 . _ M _ _ _ _ 2 . 2 A - -			137	100L
23	62.38	885	3.09	17400	5 6 .				
21	68.52	972	2.88	17723	6 3 .				
17	83.97	1194	2.40	18389	7 1 .				
16	91.70	1302	2.22	18663	9 0 .				
14	105.59	1489	1.81	19113	1 0 0				
13	114.15	1602	2.12	19393	F 0 8 3 2 1 0 0 _ M _ _ _ _ 2 . 2 A - -	139	100L		
11	124.92	1754	1.93	19600	1 1 2				
10	141.33	1984	1.71	19700	1 2 5				
9.0	159.53	2237	1.52	19700	1 6 0				
19	76.14	1079	3.34	29900	F 0 9 2 1 8 0 . _ M _ _ _ _ 2 . 2 A - -	187	100L		
16	87.44	1240	3.47	29900	9 0 .				
15	98.32	1391	3.10	29900	1 0 0				
14	102.48	1441	2.94	29890	F 0 9 3 1 1 0 0 _ M _ _ _ _ 2 . 2 A - -	197	100L		
13	113.85	1603	2.64	29882	1 1 2				
11	132.34	1856	2.32	29865	1 2 5				
10	147.03	2063	2.09	29826	1 4 0				
8.9	160.82	2257	1.88	29826	1 6 0				
8.1	177.54	2495	1.70	29820	1 8 0				
6.9	207.69	2904	1.48	29780	2 0 0				
6.2	229.28	3215	1.34	29771	2 2 5				
5.9	244.23	3426	1.24	29771	2 5 0				
5.2	274.63	3844	1.10	29706	2 8 0				
4.5	315.41	4410	0.98	29697	3 1 5				
4.0	354.67	4955	0.87	29630	3 6 0				
12	114.24	1632	3.92	43400	F 1 0 3 1 1 1 2 _ M _ _ _ _ 2 . 2 A - -			302	100L
11	129.50	1842	3.93	43400	1 2 5				
10	143.90	2047	3.54	43400	1 4 0				
8.7	162.91	2327	2.75	43400	1 6 0				
7.5	187.70	2581	2.39	43400	1 8 0				
6.9	205.21	2918	2.48	43400	2 0 0				
6.0	236.45	3361	2.16	43300	2 2 5				
5.6	253.86	3619	1.77	43300	2 5 0				
5.2	272.75	3881	1.65	43300	2 8 0				
4.4	319.79	4543	1.60	43300	3 1 5				
4.1	343.57	4867	1.49	43300	3 6 0				
3.5	400.73	5633	1.29	43000	F 1 0 4 1 4 0 0 _ M _ _ _ _ 2 . 2 A - -	312	100L		
3.2	445.30	6259	1.16	43000	4 5 0				
2.9	489.83	6885	1.05	43000	5 0 0				
2.5	562.85	7911	0.92	43000	5 6 0				
2.2	638.26	8971	0.81	43000	6 3 0				
5.2	277.27	4074	2.48	56000	F 1 1 3 1 2 8 0 _ M _ _ _ _ 2 . 2 A - -	346	100L		
4.5	315.83	4640	2.29	56000	3 1 5				
150	6.26	136	2.11	3553	F 0 3 2 2 7 . 1 _ M _ _ _ _ 2 . 2 C - -	68	112M		
107	8.78	190	1.68	3535	9 . 0				
97	9.68	210	1.56	3561	1 0 .				
86	10.99	238	1.38	3581	1 2 .				
67	13.96	303	1.11	3571	1 4 .				
59	15.86	344	1.03	3528	1 6 .				
48	19.46	422	0.90	3416	2 0 .				
44	21.59	468	0.81	3331	2 2 .				
150	6.26	136	2.11	3553	F 0 4 2 2 7 . 1 _ M _ _ _ _ 2 . 2 C - -			68	112M
107	8.78	190	1.68	3535	9 . 0				
97	9.68	210	1.56	3561	1 0 .				
86	10.99	238	1.38	3581	1 2 .				
67	13.96	303	1.11	3571	1 4 .				
59	15.86	344	1.03	3528	1 6 .				
48	19.46	422	0.90	3416	2 0 .				
44	21.59	468	0.81	3331	2 2 .				

2.2 kW

6 POLE

NOTE

Other output speeds are available using 2 and 8 pole motors - Please contact our Application Engineers

SERIES F

SELECTION TABLES

GEARED MOTORS

2.2 kW

6 POLE

N2 R/MIN	i	M2 Nm	Fm	N	Unit Designation	Kg	Motor Sizes
Output Speed	Ratio	Output Torque	Service Factor	Overhung Load	Column Entry [1] Through [20] Spaces to be filled when entering order	Weight of base mount unit	
194	4.84	105	3.76	4430	F 0 5 2 2 5 . 0 _ M _ _ _ _ 2 . 2 C - -	58	112M
138	6.81	147	3.49	4710	6 . 3		
123	7.63	165	3.36	4790	7 . 1		
110	8.56	186	3.00	4870	9 . 0		
86	10.87	236	2.60	4987	1 0 .		
76	12.33	267	2.33	5023	1 2 .		
64	14.70	319	2.01	5030	1 4 .		
56	16.93	367	1.57	5002	1 6 .		
48	19.69	427	1.52	4921	2 0 .		
43	22.03	476	1.42	4828	2 2 .		
40	23.48	508	1.34	4753	2 5 .		
34	27.83	603	1.15	4501	2 8 .		
32	29.71	643	1.09	4375	3 2 .		
25	36.87	796	0.89	3829	3 6 .		
151	6.22	135	3.76	6590	F 0 6 2 2 7 . 1 _ M _ _ _ _ 2 . 2 C - -	72	112M
107	8.75	190	3.41	7160	9 . 0		
96	9.81	213	3.24	7340	1 0 .		
85	11.01	239	3.00	7520	1 2 .		
67	13.98	304	2.65	7885	1 4 .		
59	15.85	345	2.39	8053	1 6 .		
50	18.90	411	2.05	8270	2 0 .		
43	21.76	472	1.57	8416	2 2 .		
37	25.31	549	1.52	8557	2 5 .		
33	28.32	614	1.43	8586	2 8 .		
31	30.18	654	1.36	8633	3 2 .		
26	35.77	775	1.14	8651	3 6 .		
25	38.19	829	1.07	8635	4 0 .		
20	47.40	1028	0.87	8455	5 0 .		
139	6.77	146	3.85	8950	F 0 7 2 2 7 . 1 _ M _ _ _ _ 2 . 2 C - -	92	112M
100	9.38	203	3.85	9780	9 . 0		
89	10.54	228	3.85	10100	1 0 .		
81	11.59	251	3.85	10300	1 2 .		
62	15.13	329	3.85	11000	1 4 .		
55	17.21	374	3.57	11400	1 6 .		
45	20.89	453	3.17	11800	2 0 .		
41	22.98	497	2.97	12100	2 2 .		
36	26.41	572	2.66	12394	2 5 .		
31	29.95	648	2.47	12678	2 8 .		
28	33.03	717	2.24	12849	3 2 .		
25	37.83	819	2.04	13075	3 6 .		
22	42.77	926	1.82	13297	4 0 .		
19	49.59	1070	1.62	13448	5 0 .		
16	59.14	1276	1.40	13606	5 6 .		
15	64.77	1397	1.30	13634	6 3 .		
12	77.72	1677	0.98	13477	7 1 .		
27	34.55	748	3.44	16700	F 0 8 2 2 3 2 . _ M _ _ _ _ 2 . 2 C - -	143	112M
24	39.09	849	3.19	17200	3 6 .		
21	44.13	956	2.91	17600	4 0 .		
18	53.49	1159	2.48	18240	5 0 .		
15	62.38	1349	2.19	18757	5 6 .		
14	68.52	1478	2.03	19050	6 3 .		
11	83.97	1817	1.70	19524	7 1 .		
10	91.70	1980	1.58	19658	9 0 .		
8.9	105.59	2270	1.29	19700	1 0 0		
8.2	114.15	2441	1.39	20014	F 0 8 3 2 1 0 0 _ M _ _ _ _ 2 . 2 C - -	145	112M
7.5	124.92	2672	1.27	20059	1 1 2		
6.7	141.33	3022	1.12	19995	1 2 5		
5.9	159.53	3415	0.99	18688	1 6 0		
4.9	193.39	4117	0.82	16008	1 8 0		
16	57.58	1246	3.46	29900	F 0 9 2 1 5 6 . _ M _ _ _ _ 2 . 2 C - -	193	112M
15	63.56	1377	3.13	29900	6 3 .		
14	67.71	1464	2.70	29876	7 1 .		
12	76.14	1641	2.23	29865	8 0 .		
11	87.44	1887	2.28	29856	9 0 .		
10	98.32	2118	2.03	29848	1 0 0		
9.2	102.48	2200	1.93	29863	F 0 9 3 1 1 0 0 _ M _ _ _ _ 2 . 2 C - -	203	112M
8.3	113.85	2442	1.74	29826	1 1 2		
7.1	132.34	2831	1.52	29790	1 2 5		
6.4	147.03	3144	1.37	29776	1 4 0		
5.8	160.82	3439	1.23	29776	1 6 0		
5.3	177.54	3810	1.11	29714	1 8 0		
4.5	207.69	4442	0.97	29711	2 0 0		
4.1	229.28	4890	0.88	29617	2 2 5		
3.8	244.23	5234	0.81	29617	2 5 0		
13	74.39	1599	3.51	43400	F 1 0 2 1 8 0 . _ M _ _ _ _ 2 . 2 C - -	289	112M
11	87.21	1871	3.87	43400	9 0 .		
10	93.70	2009	3.51	43400	1 0 0		

NOTE
Other output speeds are available using 2 and 8 pole motors - Please contact our Application Engineers

SERIES F

SELECTION TABLES

GEARED MOTORS

2.2 kW

6 POLE

N2 R/MIN	i	M2 Nm	Fm	N	Unit Designation	Kg	Motor Sizes
Output Speed	Ratio	Output Torque	Service Factor	Overhung Load	Column Entry [1] Through [20] Spaces to be filled when entering order	Weight of base mount unit	
9.2	102.80	2197	2.91	43400	F 1 0 3 1 1 0 0 _ M _ _ _ _ 2 . 2 C - -	310	112M
8.3	114.24	2440	2.62	43400	1 1 2		
7.3	129.50	2755	2.63	43400	1 2 5		
6.6	143.90	3062	2.37	43400	1 4 0		
5.8	162.91	3480	1.84	43400	1 6 0		
5.0	187.70	4006	1.60	43300	1 8 0		
4.6	205.21	4367	1.66	43300	2 0 0		
4.0	236.45	5016	1.45	43300	2 2 5		
3.7	253.86	5397	1.19	43300	2 5 0		
3.5	272.75	5790	1.11	43300	2 8 0		
3.0	319.79	6779	1.07	43300	3 1 5		
2.8	343.57	7265	1.00	43200	3 6 0		
2.4	400.73	8419	0.86	43000	F 1 0 4 1 4 0 0 _ M _ _ _ _ 2 . 2 C - -	320	112M
4.2	225.59	5040	2.01	56000	F 1 1 3 1 2 2 5 _ M _ _ _ _ 2 . 2 M - -	346	100L
3.7	256.85	5741	1.85	56000	2 5 0		
3.4	277.27	6197	1.63	56000	2 8 0		
3.0	315.83	7059	1.50	56000	3 1 5		
4.2	225.59	5040	2.01	56000	F 1 1 3 1 2 2 5 _ M _ _ _ _ 2 . 2 C - -	347	112M
3.7	256.85	5741	1.85	56000	2 5 0		
3.4	277.27	6197	1.63	56000	2 8 0		
3.0	315.83	7059	1.50	56000	3 1 5		

3.0 kW

4 POLE

228	6.26	122	2.35	2985	F 0 3 2 2 7 . 1 _ M _ _ _ _ 3 . 0 A - -	48	100L		
163	8.78	171	1.84	3039	9 . 0				
148	9.68	188	1.70	3058	1 0 .				
130	10.99	214	1.53	3072	1 2 .				
102	13.96	271	1.24	3051	1 4 .				
90	15.86	308	1.12	3012	1 6 .				
73	19.46	378	0.94	2904	2 0 .				
66	21.59	420	0.86	2827	2 2 .				
58	24.53	477	0.78	2702	2 5 .				
228	6.26	122	2.35	2985	F 0 4 2 2 7 . 1 _ M _ _ _ _ 3 . 0 A - -			48	100L
163	8.78	171	1.84	3039	9 . 0				
148	9.68	188	1.70	3058	1 0 .				
130	10.99	214	1.53	3072	1 2 .				
102	13.96	271	1.24	3051	1 4 .				
90	15.86	308	1.12	3012	1 6 .				
73	19.46	378	0.94	2904	2 0 .				
66	21.59	420	0.86	2827	2 2 .				
58	24.53	477	0.80	2702	2 5 .				
210	6.81	133	3.88	4070	F 0 5 2 2 6 . 3 _ M _ _ _ _ 3 . 0 A - -	55	100L		
187	7.63	148	3.65	4140	7 . 1				
167	8.56	166	3.35	4200	9 . 0				
132	10.87	211	2.74	4289	1 0 .				
116	12.33	240	2.46	4307	1 2 .				
97	14.70	285	2.12	4306	1 4 .				
84	16.93	329	1.75	4268	1 6 .				
73	19.69	382	1.64	4184	2 0 .				
65	22.03	427	1.50	4091	2 2 .				
61	23.48	456	1.41	4013	2 5 .				
51	27.83	539	1.22	3771	2 8 .				
48	29.71	576	1.16	3649	3 2 .				
39	36.87	715	0.96	3130	3 6 .				
33	43.47	841	0.83	2590	4 0 .				
230	6.22	120	3.88	5730	F 0 6 2 2 7 . 1 _ M _ _ _ _ 3 . 0 A - -	69	100L		
163	8.75	170	3.35	6210	9 . 0				
146	9.81	190	3.20	6360	1 0 .				
130	11.01	214	3.02	6517	1 2 .				
102	13.98	272	2.68	6815	1 4 .				
90	15.85	308	2.51	6957	1 6 .				
76	18.90	368	2.27	7135	2 0 .				
66	21.76	424	1.75	7250	2 2 .				
56	25.31	493	1.70	7345	2 5 .				
50	28.32	550	1.60	7393	2 8 .				
47	30.18	587	1.52	7399	3 2 .				
40	35.77	695	1.28	7384	3 6 .				
37	38.19	741	1.20	7367	4 0 .				
30	47.40	919	0.97	7180	5 0 .				
26	55.89	1085	0.82	6920	5 6 .				
94	15.13	294	3.94	9560	F 0 7 2 2 1 4 . _ M _ _ _ _ 3 . 0 A - -			89	100L
83	17.21	334	3.65	9840	1 6 .				
68	20.89	407	3.24	10300	2 0 .				
62	22.98	445	3.03	10400	2 2 .				
54	26.41	512	2.71	10715	2 5 .				
48	29.95	580	2.51	10926	2 8 .				
43	33.03	642	2.29	11076	3 2 .				
38	37.83	736	2.08	11272	3 6 .				
33	42.77	833	1.86	11432	4 0 .				
29	49.59	959	1.65	11589	5 0 .				
24	59.14	1146	1.43	11658	5 6 .				
22	64.77	1256	1.32	11637	6 3 .				
18	77.72	1497	1.06	11510	7 1 .				

NOTE

Other output speeds are available using 2 and 8 pole motors - Please contact our Application Engineers

SERIES F

SELECTION TABLES

GEARED MOTORS

3.0 kW

N2 R/MIN	i	M2 Nm	Fm	N	Unit Designation	Kg	Motor Sizes
Output Speed	Ratio	Output Torque	Service Factor	Overhung Load	Column Entry 1 Through 20 Spaces to be filled when entering order	Weight of base mount unit	
41	34.55	673	3.68	14500	F 0 8 2 2 3 2 . _ M _ _ _ _ 3 . 0 A - -	140	100L
37	39.09	759	3.39	14900	3 6 .		
32	44.13	858	3.06	15300	4 0 .		
27	53.49	1035	2.59	15773	5 0 .		
23	62.38	1207	2.27	16198	5 6 .		
21	68.52	1326	2.11	16407	6 3 .		
17	83.97	1628	1.76	16777	7 1 .		
16	91.70	1776	1.63	16907	9 0 .		
14	105.59	2030	1.32	17086	1 0 0		
13	114.15	2184	1.55	17206	F 0 8 3 2 1 0 0 _ M _ _ _ _ 3 . 0 A - -	142	100L
11	124.92	2392	1.42	17200	1 1 2		
10	141.33	2706	1.25	17101	1 2 5		
22	63.56	1236	3.48	29900	F 0 9 2 1 6 3 . _ M _ _ _ _ 3 . 0 A - -	190	100L
21	67.71	1311	2.74	29900	7 1 .		
19	76.14	1471	2.45	29877	8 0 .		
16	87.44	1691	2.55	29865	9 0 .		
15	98.32	1897	2.27	29869	1 0 0		
14	102.48	1966	2.16	29869	F 0 9 3 1 1 0 0 _ M _ _ _ _ 3 . 0 A - -	200	100L
13	113.85	2186	1.94	29863	1 1 2		
11	132.34	2531	1.70	29826	1 2 5		
10	147.03	2813	1.53	29773	1 4 0		
8.9	160.82	3078	1.38	29773	1 6 0		
8.1	177.54	3403	1.25	29769	1 8 0		
6.9	207.69	3960	1.09	29704	2 0 0		
6.2	229.28	4384	0.98	29700	2 2 5		
5.9	244.23	4673	0.91	29700	2 5 0		
5.2	274.63	5243	0.81	29600	2 8 0		
19	74.39	1456	3.85	43400	F 1 0 3 1 8 0 . _ M _ _ _ _ 3 . 0 A - -	286	100L
16	87.21	1720	4.00	43400	9 0 .		
15	93.70	1827	3.85	43400	1 0 0		
14	102.80	1989	3.20	43400	F 1 0 3 1 1 0 0 _ M _ _ _ _ 3 . 0 A - -	305	100L
12	114.24	2210	2.90	43400	1 1 2		
11	129.50	2495	2.91	43400	1 2 5		
10	143.90	2772	2.61	43400	1 4 0		
8.7	162.91	3152	2.03	43400	1 6 0		
7.6	187.70	3630	1.76	43400	1 8 0		
6.9	205.21	3951	1.83	43400	2 0 0		
6.0	236.45	4551	1.59	43400	2 2 5		
5.6	253.86	4901	1.31	43400	2 5 0		
5.2	272.75	5258	1.22	43400	2 8 0		
4.4	319.79	6152	1.18	43400	3 1 5		
4.1	343.57	6590	1.10	43400	3 6 0		
6.3	225.49	4518	2.24	56000	F 1 1 3 1 2 2 5 _ M _ _ _ _ 3 . 0 A - -	344	100L
5.6	256.85	5146	2.06	56000	2 5 0		
5.2	277.27	5555	1.82	56000	2 8 0		
4.5	315.83	6328	1.68	56000	3 1 5		

3.0 kW

6 POLE

198	4.84	140	2.81	4113	F 0 5 2 2 5 . 0 _ M _ _ _ _ 3 . 0 C - -	71	132S
141	6.81	197	2.61	4265	6 . 3		
126	7.63	221	2.51	4292	7 . 1		
112	8.56	248	2.25	4310	9 . 0		
88	10.87	315	1.95	4275	1 0 .		
78	12.33	357	1.75	4217	1 2 .		
65	14.70	426	1.50	4070	1 4 .		
57	16.93	490	1.17	3899	1 6 .		
49	19.69	570	1.14	3636	2 0 .		
44	22.03	636	1.06	3393	2 2 .		
41	23.48	678	1.01	3221	2 5 .		
35	27.83	806	0.86	2686	2 8 .		
32	29.71	859	0.81	2441	3 2 .		
154	6.22	180	2.81	6299	F 0 6 2 2 7 . 1 _ M _ _ _ _ 3 . 0 C - -	85	132S
110	8.75	254	2.55	6748	9 . 0		
98	9.81	285	2.42	6879	1 0 .		
87	11.01	319	2.25	7002	1 2 .		
69	13.98	406	1.99	7228	1 4 .		
61	15.85	460	1.79	7309	1 6 .		
51	18.90	549	1.53	7382	2 0 .		
44	21.76	631	1.17	7395	2 2 .		
38	25.31	734	1.14	7363	2 5 .		
34	28.32	819	1.07	7268	2 8 .		
32	30.18	874	1.02	7217	3 2 .		
27	35.77	1035	0.86	6970	3 6 .		
25	38.19	1107	0.80	6835	4 0 .		

NOTE

Other output speeds are available using 2 and 8 pole motors - Please contact our Application Engineers

SERIES F

SELECTION TABLES

GEARED MOTORS

3.0 kW

6 POLE

N2 R/MIN	i	M2 Nm	Fm	N	Unit Designation	Kg	Motor Sizes
Output Speed	Ratio	Output Torque	Service Factor	Overhung Load	Column Entry [1] Through [20] Spaces to be filled when entering order	Weight of base mount unit	
142	6.77	195	2.88	8684	F 0 7 2 2 7 . 1 _ M _ _ _ _ 3 . 0 C - -	104	132S
102	9.38	271	2.88	9411	9 . 0		
91	10.54	305	2.88	9683	1 0 .		
83	11.59	336	2.88	9850	1 2 .		
63	15.13	440	2.88	10409	1 4 .		
56	17.21	500	2.68	10717	1 6 .		
46	20.89	605	2.38	10986	2 0 .		
42	22.98	664	2.23	11194	2 2 .		
36	26.41	763	1.99	11360	2 5 .		
32	29.95	866	1.85	11504	2 8 .		
29	33.03	958	1.68	11559	3 2 .		
25	37.83	1093	1.53	11602	3 6 .		
22	42.77	1236	1.37	11623	4 0 .		
19	49.59	1429	1.21	11520	5 0 .		
16	59.14	1704	1.05	11292	5 6 .		
15	64.77	1865	0.97	11114	6 3 .		
39	24.45	708	3.50	14700	F 0 8 2 2 2 2 . _ M _ _ _ _ 3 . 0 C - -	158	132S
34	28.46	824	3.17	15200	2 5 .		
30	31.57	912	2.87	15500	2 8 .		
28	34.55	1000	2.58	15688	3 2 .		
25	39.09	1133	2.39	16057	3 6 .		
22	44.13	1277	2.18	16315	4 0 .		
18	53.49	1548	1.86	16687	5 0 .		
15	62.38	1802	1.64	16941	5 6 .		
14	68.52	1973	1.52	17050	6 3 .		
11	83.97	2426	1.27	17068	7 1 .		
10	91.70	2644	1.18	17010	9 0 .		
9.1	105.59	3031	0.96	16878	1 0 0		
8.4	114.15	3259	1.04	16712	F 0 8 3 2 1 0 0 _ M _ _ _ _ 3 . 0 C - -	160	132S
7.7	124.92	3568	0.95	16451	1 1 2		
6.8	141.33	4035	0.84	15910	1 2 5		
24	40.76	1175	3.67	29900	F 0 9 2 1 4 0 . _ M _ _ _ _ 3 . 0 C - -	205	132S
22	44.58	1291	3.28	29900	4 5 .		
20	49.22	1426	2.97	29875	5 0 .		
17	57.58	1664	2.59	29869	5 6 .		
15	63.56	1839	2.34	29869	6 3 .		
14	67.71	1955	2.02	29850	7 1 .		
13	76.14	2191	1.67	29826	8 0 .		
11	87.44	2520	1.71	29806	9 0 .		
10	98.32	2829	1.52	29790	1 0 0		
15	64.49	1878	3.86	43400	F 1 0 2 1 6 3 . _ M _ _ _ _ 3 . 0 C - -	300	132S
14	69.24	2022	3.05	43400	7 1 .		
13	74.39	2169	2.59	43400	8 0 .		
11	87.21	2537	2.86	43400	9 0 .		
10	93.70	2726	2.59	43400	1 0 0		
9.2	102.80	2980	2.15	43400	F 1 0 3 1 1 0 0 _ M _ _ _ _ 3 . 0 C -	320	132S
8.3	114.24	3310	1.93	43400	1 1 2		
7.3	129.50	3737	1.94	43400	1 2 5		
6.6	143.90	4154	1.74	43400	1 4 0		
5.8	162.91	4720	1.36	43400	1 6 0		
5.1	187.70	5434	1.18	43400	1 8 0		
4.6	205.21	5924	1.22	43400	2 0 0		
4.0	236.45	6804	1.07	43400	2 2 5		
3.7	253.86	7321	0.87	43400	2 5 0		
3.5	272.75	7855	0.81	43400	2 8 0		
4.1	225.49	6909	1.46	56000	F 1 1 3 1 2 2 5 _ M _ _ _ _ 3 . 0 M -	353	112M
3.6	256.85	7870	1.35	56000	2 5 0		
3.4	277.27	8496	1.19	56000	2 8 0		
3.0	315.83	9678	1.10	56000	3 1 5		
4.3	225.49	6729	1.50	56000	F 1 1 3 1 2 2 5 _ M _ _ _ _ 3 . 0 M -	359	132S
3.7	256.85	7665	1.39	56000	2 5 0		
3.5	277.27	8275	1.22	56000	2 8 0		
3.0	315.83	9426	1.13	56000	3 1 5		
4.2	229.54	6850	2.41	62200	F 1 2 3 1 2 2 5 _ M _ _ _ _ 3 . 0 C -	545	132S
3.9	247.92	7399	2.22	62200	2 5 0		
3.4	285.33	8515	1.94	62200	2 8 0		
3.1	308.18	9197	1.79	62200	3 1 5		

NOTE

Other output speeds are available using 2 and 8 pole motors - Please contact our Application Engineers

SERIES F

SELECTION TABLES

GEARED MOTORS

4.0 kW

4 POLE

N2 R/MIN	i	M2 Nm	Fm	N	Unit Designation	Kg	Motor Sizes
Output Speed	Ratio	Output Torque	Service Factor	Overhung Load	Column Entry [1] Through [20] Spaces to be filled when entering order	Weight of base mount unit	
228.4	6.26	162	1.76	2694	F 0 3 2 2 7 . 1 _ M _ _ _ _ 4 . 0 A - -	68	112M
162.8	8.78	228	1.38	2635	9 . 0		
147.7	9.68	251	1.27	2613	1 0 .		
130.1	10.99	285	1.14	2569	1 2 .		
102.4	13.96	362	0.93	2424	1 4 .		
90.2	15.86	411	0.84	2313	1 6 .		
228.4	6.26	162	1.76	2694	F 0 4 2 2 7 . 1 _ M _ _ _ _ 4 . 0 A - -	68	112M
162.8	8.78	228	1.38	2635	9 . 0		
147.7	9.68	251	1.27	2613	1 0 .		
130.1	10.99	285	1.14	2569	1 2 .		
102.4	13.96	362	0.93	2424	1 4 .		
90.2	15.86	411	0.84	2313	1 6 .		
296	4.84	124	3.17	3580	F 0 5 2 2 5 . 0 _ M _ _ _ _ 4 . 0 A - -	58	112M
211	6.81	176	2.92	3702	6 . 3		
188	7.63	197	2.75	3727	7 . 1		
168	8.56	220	2.52	3736	9 . 0		
132	10.87	281	2.06	3701	1 0 .		
116	12.33	318	1.85	3641	1 2 .		
98	14.70	379	1.59	3512	1 4 .		
85	16.93	437	1.31	3353	1 6 .		
73	19.69	508	1.24	3121	2 0 .		
65	22.03	567	1.13	2902	2 2 .		
61	23.48	606	1.06	2746	2 5 .		
52	27.83	717	0.92	2270	2 8 .		
48	29.71	765	0.87	2049	3 2 .		
231	6.22	160	2.92	5487	F 0 6 2 2 7 . 1 _ M _ _ _ _ 4 . 0 A - -	72	112M
164	8.75	227	2.52	5868	9 . 0		
146	9.81	253	2.40	5979	1 0 .		
130	11.01	285	2.28	6088	1 2 .		
103	13.98	362	2.02	6272	1 4 .		
91	15.85	410	1.89	6341	1 6 .		
76	18.90	489	1.71	6400	2 0 .		
66	21.76	564	1.31	6404	2 2 .		
57	25.31	655	1.28	6362	2 5 .		
51	28.32	731	1.20	6296	2 8 .		
48	30.18	781	1.14	6230	3 2 .		
40	35.77	923	0.96	6007	3 6 .		
38	38.19	985	0.90	5887	4 0 .		
212	6.77	174	3.24	7570	F 0 7 2 2 7 . 1 _ M _ _ _ _ 4 . 0 A - -	92	112M
153	9.38	241	3.24	8200	9 . 0		
136	10.54	271	3.24	8420	1 0 .		
124	11.59	298	3.24	8590	1 2 .		
95	15.13	390	2.97	9069	1 4 .		
83	17.21	444	2.75	9282	1 6 .		
69	20.89	541	2.44	9616	2 0 .		
62	22.98	591	2.28	9660	2 2 .		
54	26.41	680	2.04	9859	2 5 .		
48	29.95	771	1.89	9959	2 8 .		
43	33.03	853	1.72	10013	3 2 .		
38	37.83	978	1.56	10054	3 6 .		
34	42.77	1106	1.40	10054	4 0 .		
29	49.59	1274	1.24	9981	5 0 .		
24	59.14	1523	1.08	9741	5 6 .		
22	64.77	1669	0.99	9557	6 3 .		
59	24.45	632	3.59	12800	F 0 8 2 2 2 2 . _ M _ _ _ _ 4 . 0 A - -	143	112M
50	28.46	737	3.24	13200	2 5 .		
45	31.57	814	3.02	13500	2 8 .		
42	34.55	894	2.77	13665	3 2 .		
37	39.09	1008	2.55	13954	3 6 .		
33	44.13	1140	2.31	14230	4 0 .		
27	53.49	1376	1.95	14490	5 0 .		
23	62.38	1605	1.71	14696	5 6 .		
21	68.52	1762	1.59	14761	6 3 .		
17	83.97	2164	1.33	14762	7 1 .		
16	91.70	2359	1.22	14712	9 0 .		
14	105.59	2697	1.00	14553	1 0 0		
13	114.15	2902	1.17	14473	F 0 8 3 2 1 0 0 0 _ M _ _ _ _ 4 . 0 A - -	145	112M
11	124.92	3179	1.07	14200	1 1 2		
10	141.33	3596	0.94	13736	1 2 5		
9.0	159.53	4053	0.84	13080	1 6 0		
32	44.58	1150	3.69	29900	F 0 9 2 1 4 5 . _ M _ _ _ _ 4 . 0 A - -	193	112M
29	49.22	1269	3.34	29900	5 0 .		
25	57.58	1488	2.89	29900	5 6 .		
23	63.56	1643	2.62	29877	6 3 .		
21	67.71	1742	2.07	29883	7 1 .		
19	76.14	1955	1.84	29848	8 0 .		
16	87.44	2247	1.92	29822	9 0 .		
15	98.32	2521	1.71	29832	1 0 0		

NOTE
Other output speeds are available using 2 and 8 pole motors - Please contact our Application Engineers

SERIES F

SELECTION TABLES

GEARED MOTORS

4.0 kW

4 POLE

N2 R/MIN	i	M2 Nm	Fm	N	Unit Designation	Kg	Motor Sizes		
Output Speed	Ratio	Output Torque	Service Factor	Overhung Load	Column Entry [1] Through [20] Spaces to be filled when entering order	Weight of base mount unit			
14	102.48	2612	1.62	29842	F 0 9 3 1 1 0 0 _ M _ _ _ _ 4 . 0 A - -	203	112M		
13	113.85	2904	1.46	29839	1 1 2				
11	132.34	3362	1.28	29778	1 2 5				
10	147.03	3738	1.15	29706	1 4 0				
8.9	160.82	4090	1.04	29706	1 6 0				
8.1	177.54	4521	0.94	29706	1 8 0				
6.9	207.69	5262	0.82	29609	2 0 0				
21	69.24	1793	3.44	43400	F 1 0 2 1 7 1 _ _ M _ _ _ _ 4 . 0 A - -			292	112M
19	74.39	1935	2.90	43400	8 0 .				
16	87.21	2252	3.22	43400	9 0 .	312	112M		
15	93.70	2428	2.90	43400	1 0 0				
14	102.80	2642	2.41	43300	F 1 0 3 1 1 0 0 _ M _ _ _ _ 4 . 0 A - -				
12	114.24	2936	2.18	43300	1 1 2				
11	129.50	3315	2.19	43300	1 2 5				
10	143.90	3683	1.97	43300	1 4 0				
8.7	162.91	4187	1.53	43300	1 6 0				
7.6	1087.70	4823	1.33	43300	1 8 0				
6.9	205.21	5250	1.38	43300	2 0 0				
6.0	236.45	6046	1.20	43200	2 2 5				
5.6	253.86	6512	0.98	43200	2 5 0				
5.2	272.75	6982	0.92	43200	2 8 0				
4.4	319.79	8174	0.89	43200	3 1 5				
4.1	343.57	8756	0.83	43100	3 6 0				
8.9	160.35	4314	2.46	56000	F 1 1 3 1 1 6 0 _ M _ _ _ _ 4 . 0 K - -			347	100L
8.0	178.07	4790	2.11	56000	1 8 0				
7.0	202.84	5457	1.95	56000	2 0 0				
6.3	225.49	6066	1.67	56000	2 2 5				
5.5	256.85	6910	1.54	56000	2 5 0				
5.1	277.27	7459	1.36	56000	2 8 0				
4.5	315.83	8946	1.25	56000	3 1 5				
8.9	160.35	4269	2.49	56000	F 1 1 3 1 1 6 0 _ M _ _ _ _ 4 . 0 A - -	347	112M		
8.1	178.07	4740	2.13	56000	1 8 0				
7.1	202.84	5400	1.97	56000	2 0 0				
6.4	225.49	6003	1.69	56000	2 2 5				
5.6	256.85	6837	1.55	56000	2 5 0				
5.2	277.27	7381	1.37	56000	2 8 0				
4.5	315.83	8407	1.26	56000	3 1 5				

4.0 kW

6 POLE

198	4.84	187	2.11	3718	F 0 5 2 2 5 . 0 _ M _ _ _ _ 4 . 0 C - -	78	132M		
141	6.81	263	1.96	3709	6 . 3				
126	7.63	294	1.88	3670	7 . 1				
112	8.56	331	1.68	3610	9 . 0				
88	10.87	420	1.46	3386	1 0 .				
78	12.33	477	1.31	3209	1 2 .				
65	14.70	568	1.13	2870	1 4 .				
57	16.93	653	0.88	2520	1 6 .				
49	19.69	760	0.86	2030	2 0 .				
154	6.22	241	2.11	5935	F 0 6 2 2 7 . 1 _ M _ _ _ _ 4 . 0 C - -			92	132M
110	8.75	338	1.91	6233	9 . 0				
98	9.81	380	1.82	6303	1 0 .				
87	11.01	426	1.68	6356	1 2 .				
69	13.98	542	1.49	6407	1 4 .				
61	15.85	614	1.34	6379	1 6 .				
51	18.90	732	1.15	6273	2 0 .				
44	21.76	842	0.88	6120	2 2 .				
38	25.31	978	0.86	5870	2 5 .				
34	28.32	1093	0.81	5620	2 8 .				
142	6.77	261	2.16	8352	F 0 7 2 2 7 . 1 _ M _ _ _ _ 4 . 0 C - -	111	132M		
102	9.38	362	2.16	8951	9 . 0				
91	10.54	407	2.16	9162	1 0 .				
83	11.59	448	2.16	9287	1 2 .				
63	15.13	587	2.16	9672	1 4 .				
56	17.21	667	2.01	9864	1 6 .				
46	20.89	807	1.78	9969	2 0 .				
42	22.98	886	1.67	10062	2 2 .				
36	26.41	1018	1.49	10066	2 5 .				
32	29.95	1155	1.38	10036	2 8 .				
29	33.03	1277	1.26	9947	3 2 .				
25	37.83	1458	1.14	9761	3 6 .				
22	42.77	1648	1.02	9530	4 0 .				
19	49.59	1906	0.91	9110	5 0 .				

NOTE

Other output speeds are available using 2 and 8 pole motors - Please contact our Application Engineers

SERIES F

SELECTION TABLES

GEARED MOTORS

4.0 kW

6 POLE

N2 R/MIN	i	M2 Nm	Fm	N	Unit Designation	Kg	Motor Sizes
Output Speed	Ratio	Output Torque	Service Factor	Overhung Load	Column Entry [1] Through [20] Spaces to be filled when entering order	Weight of base mount unit	
61	15.76	611	3.55	12700	F 0 8 2 2 1 4 . _ M _ _ _ _ 4 . 0 C - -	165	132M
54	17.70	684	3.30	13000	1 6 .		
44	21.70	841	2.88	13500	2 0 .		
39	24.45	944	2.62	13806	2 2 .		
34	28.46	1098	2.38	14156	2 5 .		
30	31.57	1217	2.15	14345	2 8 .		
28	34.55	1333	1.93	14424	3 2 .		
25	39.09	1511	1.79	14629	3 6 .		
22	44.13	1702	1.63	14709	4 0 .		
18	53.49	2064	1.39	14745	5 0 .		
15	62.38	2403	1.23	14671	5 6 .		
14	68.52	2631	1.14	14550	6 3 .		
11	83.97	3235	0.95	14000	7 1 .		
10	91.70	3525	0.88	13700	9 0 .		
34	28.41	1101	3.85	29900	F 0 9 2 1 2 8 . _ M _ _ _ _ 4 . 0 C - -	212	132M
30	31.56	1220	3.47	29900	3 2 .		
26	36.69	1413	3.05	29877	3 6 .		
24	40.76	1567	2.75	29875	4 0 .		
22	44.58	1721	2.46	29875	4 5 .		
20	49.22	1901	2.23	29841	5 0 .		
17	57.58	2218	1.94	29832	5 6 .		
15	63.56	2452	1.76	29832	6 3 .		
14	67.71	2607	1.51	29816	7 1 .		
13	76.14	2922	1.25	29778	8 0 .		
11	87.44	3360	1.28	29743	9 0 .		
10	98.32	3772	1.14	29717	1 0 0		
21	44.43	1727	3.71	43400	F 1 0 2 1 4 5 . _ M _ _ _ _ 4 . 0 C - -	310	132M
19	51.19	1994	3.21	43400	5 0 .		
17	55.97	2175	3.33	43400	5 6 .		
15	64.49	2491	2.91	43400	6 3 .		
14	69.24	2682	2.30	43400	7 1 .		
13	74.39	2877	1.95	43400	8 0 .		
11	87.21	3366	2.15	43400	9 0 .		
10	93.70	3615	1.95	43400	1 0 0		
9.3	102.80	3953	1.62	43300	F 1 0 3 1 1 0 0 _ M _ _ _ _ 4 . 0 C - -	329	132M
8.4	114.24	4391	1.46	43300	1 1 2		
7.4	129.50	4957	1.46	43300	1 2 5		
6.6	143.90	5510	1.32	43300	1 4 0		
5.9	162.91	6261	1.02	43300	1 6 0		
5.1	187.70	7208	0.89	43200	1 8 0		
4.7	205.21	7857	0.92	43200	2 0 0		
4.0	236.45	9025	0.80	43100	2 2 5		
4.3	225.49	8973	1.13	56000	F 1 1 3 1 2 2 5 _ M _ _ _ _ 4 . 0 C - -	366	132M
3.7	256.85	10220	1.04	56000	2 5 0		
3.5	277.27	11033	0.92	56000	2 8 0		
3.0	315.83	12567	0.84	56000	3 1 5		
4.2	229.54	9134	1.81	62200	F 1 2 3 1 2 2 5 _ M _ _ _ _ 4 . 0 C - -	552	132M
3.9	247.92	9865	1.67	62200	2 5 0		
3.4	285.33	11354	1.46	62200	2 8 0		
3.1	308.18	12263	1.34	62200	3 1 5		

5.5 kW

4 POLE

300	4.84	169	2.33	3186	F 0 5 2 2 5 . 0 _ M _ _ _ _ 5 . 5 A - -	72	132S
213	6.81	240	2.15	3150	6 . 3		
190	7.63	268	2.02	3108	7 . 1		
169	8.56	300	1.85	3041	9 . 0		
133	10.87	382	1.52	2818	1 0 .		
118	12.33	433	1.36	2642	1 2 .		
99	14.70	516	1.17	2320	1 4 .		
86	16.93	595	0.97	1981	1 6 .		
74	19.69	691	0.91	1526	2 0 .		
66	22.03	772	0.83	1118	2 2 .		
233	6.22	218	2.15	5124	F 0 6 2 2 7 . 1 _ M _ _ _ _ 5 . 5 A - -	86	132S
166	8.75	308	1.85	5357	9 . 0		
148	9.81	345	1.77	5408	1 0 .		
132	11.01	387	1.67	5445	1 2 .		
104	13.98	492	1.48	5458	1 4 .		
91	15.85	558	1.39	5418	1 6 .		
77	18.90	666	1.26	5299	2 0 .		
67	21.76	767	0.97	5134	2 2 .		
57	25.31	892	0.94	4888	2 5 .		
51	28.32	995	0.88	4649	2 8 .		
48	30.18	1063	0.84	4476	3 2 .		

NOTE

Other output speeds are available using 2 and 8 pole motors - Please contact our Application Engineers

SERIES F

SELECTION TABLES

GEARED MOTORS

5.5 kW

N2 R/MIN	i	M2 Nm	Fm	N	Unit Designation	Kg	
Output Speed	Ratio	Output Torque	Service Factor	Overhung Load	Column Entry 1 Through 20 Spaces to be filled when entering order	Weight of base mount unit	Motor Sizes
214	6.77	236	2.38	7240	F 0 7 2 2 7 . 1 _ M _ _ _ _ 5 . 5 A - -	105	132S
155	9.38	328	2.38	7741	9 . 0		
138	10.54	369	2.38	7905	1 0 .		
125	11.59	406	2.38	8025	1 2 .		
96	15.13	531	2.18	8332	1 4 .		
84	17.21	604	2.02	8445	1 6 .		
69	20.89	737	1.79	8591	2 0 .		
63	22.98	805	1.68	8550	2 2 .		
55	26.41	926	1.50	8576	2 5 .		
48	29.95	1049	1.39	8508	2 8 .		
44	33.03	1161	1.27	8417	3 2 .		
38	37.83	1331	1.15	8226	3 6 .		
34	42.77	1506	1.03	7987	4 0 .		
29	49.59	1734	0.91	7570	5 0 .		
92	15.76	555	3.56	11000	F 0 8 2 2 1 4 . _ M _ _ _ _ 5 . 5 A - -	159	132S
82	17.70	622	3.33	11300	1 6 .		
67	21.70	759	2.91	11666	2 0 .		
59	24.45	861	2.64	11911	2 2 .		
51	28.46	1003	2.38	12166	2 5 .		
46	31.57	1109	2.22	12350	2 8 .		
42	34.55	1217	2.04	12413	3 2 .		
37	39.09	1372	1.87	12536	3 6 .		
33	44.13	1552	1.69	12625	4 0 .		
27	53.49	1872	1.43	12566	5 0 .		
23	62.38	2184	1.25	12443	5 6 .		
21	68.52	2398	1.17	12292	6 3 .		
17	83.97	2944	0.97	11740	7 1 .		
16	91.70	3211	0.90	11419	9 0 .		
13	114.15	3950	0.86	10373	F 0 8 3 2 1 0 0 _ M _ _ _ _ 5 . 5 A - -	161	132S
40	36.69	1288	3.35	29900	F 0 9 2 1 3 6 . _ M _ _ _ _ 5 . 5 A - -	206	132S
36	40.76	1428	3.02	29872	4 0 .		
33	44.58	1565	2.71	29868	4 5 .		
29	49.22	1727	2.45	29872	5 0 .		
25	57.58	2026	2.13	29862	5 6 .		
23	63.56	2236	1.93	29844	6 3 .		
21	67.71	2371	1.52	29859	7 1 .		
19	76.14	2661	1.35	29805	8 0 .		
17	87.44	3058	1.41	29758	9 0 .		
15	98.32	3430	1.26	29775	1 0 0		
28	51.19	1805	3.55	43400	F 1 0 2 1 5 0 . _ M _ _ _ _ 5 . 5 A - -	303	132S
26	55.97	1964	3.69	43400	5 6 .		
22	64.49	2265	3.20	43400	6 3 .		
21	69.24	2423	2.55	43400	7 1 .		
19	74.39	2614	2.15	43400	8 0 .		
17	87.21	3043	2.38	43400	9 0 .		
15	93.70	3281	2.15	43400	1 0 0		
14	102.80	3571	1.78	43400	F 1 0 3 1 1 0 0 _ M _ _ _ _ 5 . 5 A - -	323	132S
13	114.24	3968	1.61	43400	1 1 2		
11	129.50	4480	1.62	43400	1 2 5		
10	143.90	4978	1.46	43400	1 4 0		
8.9	162.91	5659	1.13	43400	1 6 0		
7.7	187.70	6518	0.98	43400	1 8 0		
7.1	205.21	7095	1.02	43200	2 0 0		
6.1	236.45	8171	0.89	43100	2 2 5		
13	110.94	4089	2.47	56000	F 1 1 3 1 1 1 2 _ M _ _ _ _ 5 . 5 K - -	354	112M
11	126.37	4568	2.28	56000	1 2 5		
10	140.77	5189	1.95	56000	1 4 0		
8.9	160.35	5910	1.80	56000	1 6 0		
8.0	178.07	6564	1.54	56000	1 8 0		
7.0	202.84	7477	1.42	56000	2 0 0		
6.3	225.49	8311	1.22	56000	2 2 5		
5.5	256.85	9467	1.12	56000	2 5 0		
5.1	277.27	10220	0.99	56000	2 8 0		
4.5	315.83	11641	0.91	56000	3 1 5		
11	126.37	4578	2.32	56000	F 1 1 3 1 1 2 5 _ M _ _ _ _ 5 . 5 A - -	360	132S
10	140.77	5099	1.98	56000	1 4 0		
9.0	160.35	5809	1.83	56000	1 6 0		
8.1	178.07	6450	1.57	56000	1 8 0		
7.1	202.84	7348	1.44	56000	2 0 0		
6.4	225.49	8168	1.24	56000	2 2 5		
5.6	256.85	9304	1.14	56000	2 5 0		
5.2	277.27	10044	1.01	56000	2 8 0		
4.6	315.83	11441	0.93	56000	3 1 5		
8.0	181.27	6566	2.50	62200	F 1 2 3 1 1 8 0 _ M _ _ _ _ 5 . 5 A - -	546	132S
7.4	195.79	7092	2.31	62200	2 0 0		
6.3	229.54	8315	1.98	62200	2 2 5		
5.8	247.92	8981	1.82	62200	2 5 0		
5.1	285.33	10336	1.60	62200	2 8 0		
4.7	308.18	11164	1.47	62200	3 1 5		

NOTE

Other output speeds are available using 2 and 8 pole motors - Please contact our Application Engineers

SERIES F

SELECTION TABLES

GEARED MOTORS

5.5 kW

6 POLE

N2 R/MIN	i	M2 Nm	Fm	N	Unit Designation	Kg	Motor Sizes
Output Speed	Ratio	Output Torque	Service Factor	Overhung Load	Column Entry [1] Through [20] Spaces to be filled when entering order	Weight of base mount unit	
197	4.84	258	1.53	3126	F 0 5 2 2 5 . 0 _ M _ _ _ _ 5 . 5 C - -	86	132M
140	6.81	363	1.42	2874	6 . 3		
125	7.63	407	1.36	2737	7 . 1		
112	8.56	457	1.22	2560	9 . 0		
88	10.87	581	1.06	2051	1 0 .		
77	12.33	659	0.95	1698	1 2 .		
65	14.70	785	0.82	1070	1 4 .		
153	6.22	333	1.53	5390	F 0 6 2 2 7 . 1 _ M _ _ _ _ 5 . 5 C - -	100	132M
109	8.75	468	1.39	5461	9 . 0		
97	9.81	525	1.31	5440	1 0 .		
87	11.01	588	1.22	5387	1 2 .		
68	13.98	749	1.08	5176	1 4 .		
60	15.85	849	0.97	4984	1 6 .		
51	18.90	1012	0.83	4610	2 0 .		
141	6.77	361	1.56	7854	F 0 7 2 2 7 . 1 _ M _ _ _ _ 5 . 5 C - -	119	132M
102	9.38	501	1.56	8260	9 . 0		
91	10.54	563	1.56	8381	1 0 .		
82	11.59	619	1.56	8444	1 2 .		
63	15.13	811	1.56	8565	1 4 .		
56	17.21	922	1.45	8585	1 6 .		
46	20.89	1116	1.29	8443	2 0 .		
42	22.98	1224	1.21	8364	2 2 .		
36	26.41	1407	1.08	8126	2 5 .		
32	29.95	1596	1.00	7834	2 8 .		
29	33.03	1766	0.91	7530	3 2 .		
25	37.83	2015	0.83	7000	3 6 .		
137	6.96	371	3.15	10000	F 0 8 2 2 7 . 1 _ M _ _ _ _ 5 . 5 C - -	173	132M
97	9.87	527	3.15	10900	9 . 0		
87	10.96	584	3.15	11100	1 0 .		
78	12.19	653	2.98	11331	1 2 .		
61	15.76	844	2.57	11837	1 4 .		
54	17.70	946	2.39	12032	1 6 .		
44	21.70	1163	2.08	12315	2 0 .		
39	24.45	1305	1.90	12465	2 2 .		
34	28.46	1518	1.72	12590	2 5 .		
30	31.57	1682	1.56	12612	2 8 .		
28	34.55	1842	1.40	12528	3 2 .		
24	39.09	2089	1.30	12486	3 6 .		
22	44.13	2353	1.18	12301	4 0 .		
18	53.49	2853	1.01	11833	5 0 .		
15	62.38	3321	0.89	11266	5 6 .		
14	68.52	3637	0.82	10800	6 3 .		
34	28.41	1522	2.79	29870	F 0 9 2 1 2 8 . _ M _ _ _ _ 5 . 5 C - -	220	132M
30	31.56	1686	2.51	29872	3 2 .		
26	36.69	1953	2.21	29839	3 6 .		
23	40.76	2166	1.99	29837	4 0 .		
21	44.58	2379	1.78	29837	4 5 .		
19	49.22	2628	1.61	29789	5 0 .		
17	57.58	3066	1.41	29775	5 6 .		
15	63.56	3389	1.27	29775	6 3 .		
14	67.71	3603	1.10	29766	7 1 .		
13	76.14	4039	0.91	29704	8 0 .		
11	87.44	4645	0.93	29650	9 0 .		
10	98.32	5214	0.83	29607	1 0 0		
31	31.16	1660	3.85	43300	F 1 0 2 1 3 2 . _ M _ _ _ _ 5 . 5 C - -	319	132M
27	35.32	1872	3.87	43300	3 6 .		
24	39.25	2087	3.47	43300	4 0 .		
22	44.63	2362	2.71	43300	4 5 .		
19	51.19	2728	2.35	43300	5 0 .		
17	55.97	2975	2.44	43300	5 6 .		
15	64.49	3408	2.13	43300	6 3 .		
14	69.24	3668	1.68	43300	7 1 .		
13	74.39	3935	1.43	43300	8 0 .		
11	87.21	4604	1.57	43300	9 0 .		
10	93.70	4945	1.43	43300	1 0 0		
9.3	102.80	5407	1.18	43200	F 1 0 3 1 1 0 0 _ M _ _ _ _ 5 . 5 C - -	339	132M
8.4	114.24	6006	1.07	43200	1 1 2		
7.4	129.50	6781	1.07	43200	1 2 5		
6.7	143.90	7537	0.96	43200	1 4 0		
4.2	225.49	12402	0.82	56000	F 1 1 3 1 1 0 0 _ M _ _ _ _ 5 . 5 C - -	374	132M
4.2	229.54	12625	1.31	62200	F 1 2 3 1 2 2 5 _ M _ _ _ _ 5 . 5 C - -	560	132M
3.9	247.92	13636	1.21	62200	2 5 0		
3.3	285.33	15693	1.05	62200	2 8 0		
3.1	308.18	16950	0.97	62200	3 1 5		

NOTE
Other output speeds are available using 2 and 8 pole motors - Please contact our Application Engineers

SERIES F

SELECTION TABLES

GEARED MOTORS

7.5 kW

4 POLE

N2 R/MIN	i	M2 Nm	Fm	N	Unit Designation	Kg	Motor Sizes
Output Speed	Ratio	Output Torque	Service Factor	Overhung Load	Column Entry <input type="checkbox"/> 1 Through <input type="checkbox"/> 20 Spaces to be filled when entering order	Weight of base mount unit	
300	4.84	230	1.71	2661	F 0 5 2 2 5 . 0 _ M _ _ _ _ 7 . 5 A - -	80	132M
213	6.81	327	1.57	2415	6 . 3		
190	7.63	366	1.48	2283	7 . 1		
169	8.56	409	1.36	2115	9 . 0		
133	10.87	521	1.11	1642	1 0 .		
118	12.33	591	1.00	1310	1 2 .		
99	14.70	704	0.86	732	1 4 .		
233	6.22	297	1.57	4640	F 0 6 2 2 7 . 1 _ M _ _ _ _ 7 . 5 A - -	94	132M
166	8.75	421	1.36	4675	9 . 0		
148	9.81	470	1.30	4647	1 0 .		
132	11.01	529	1.23	4588	1 2 .		
104	13.98	671	1.09	4372	1 4 .		
91	15.85	761	1.02	4186	1 6 .		
77	18.90	908	0.92	3830	2 0 .		
214	6.77	322	1.75	6800	F 0 7 2 2 7 . 1 _ M _ _ _ _ 7 . 5 A - -	113	132M
155	9.38	448	1.75	7130	9 . 0		
138	10.54	503	1.75	7220	1 0 .		
125	11.59	554	1.75	7272	1 2 .		
96	15.13	725	1.60	7351	1 4 .		
84	17.21	824	1.48	7330	1 6 .		
69	20.89	1005	1.31	7225	2 0 .		
63	22.98	1098	1.23	7070	2 2 .		
55	26.41	1263	1.10	6864	2 5 .		
48	29.95	1431	1.02	6574	2 8 .		
44	33.03	1584	0.93	6290	3 2 .		
38	37.83	1815	0.84	5790	3 6 .		
208	6.96	333	3.51	8720	F 0 8 2 2 7 . 1 _ M _ _ _ _ 7 . 5 A - -	167	132M
147	9.87	473	3.40	9420	9 . 0		
132	10.96	523	3.23	9620	1 0 .		
119	12.19	585	3.04	9820	1 2 .		
92	15.76	757	2.61	10237	1 4 .		
82	17.70	848	2.44	10437	1 6 .		
67	21.70	1035	2.13	10618	2 0 .		
59	24.45	1174	1.93	10727	2 2 .		
51	28.46	1368	1.75	10788	2 5 .		
46	31.57	1512	1.63	10817	2 8 .		
42	34.55	1660	1.49	10745	3 2 .		
37	39.09	1871	1.37	10645	3 6 .		
33	44.13	2116	1.24	10485	4 0 .		
27	53.49	2554	1.05	10000	5 0 .		
23	62.38	2978	0.92	9440	5 6 .		
21	68.52	3271	0.86	9000	6 3 .		
51	28.41	1364	3.11	29888	F 0 9 2 1 2 8 . _ M _ _ _ _ 7 . 5 A - -	214	132M
46	31.56	1514	2.80	29876	3 2 .		
40	36.69	1756	2.45	29863	3 6 .		
36	40.76	1947	2.21	29833	4 0 .		
33	44.58	2134	1.99	29827	4 5 .		
29	49.22	2355	1.80	29836	5 0 .		
25	57.58	2762	1.56	29812	5 6 .		
23	63.56	3049	1.41	29800	6 3 .		
21	67.71	3233	1.11	29827	7 1 .		
19	76.14	3629	0.99	29748	8 0 .		
17	87.44	4170	1.03	29672	9 0 .		
15	98.32	4678	0.92	29700	1 0 0		
41	35.32	1694	3.81	43300	F 1 0 2 1 3 6 . _ M _ _ _ _ 7 . 5 A - -	313	132M
37	39.25	1879	3.56	43300	4 0 .		
33	44.63	2133	3.00	43300	4 5 .		
28	51.19	2461	2.60	43300	5 0 .		
26	55.97	2678	2.71	43300	5 6 .		
22	64.49	3089	2.35	43300	6 3 .		
21	69.24	3305	1.87	43300	7 1 .		
19	74.39	3565	1.57	43300	8 0 .		
17	87.21	4150	1.75	43300	9 0 .		
15	93.70	4474	1.57	43300	1 0 0		
14	102.80	4870	1.31	43200	F 1 0 3 1 1 0 0 _ M _ _ _ _ 7 . 5 A - -	313	132M
13	114.24	5411	1.18	43200	1 1 2		
11	129.50	6109	1.18	43200	1 2 5		
10	143.90	6788	1.07	43200	1 4 0		
8.9	162.91	7717	0.83	43200	1 6 0		
16	90.56	4473	2.26	56000	F 1 1 3 1 9 0 . _ M _ _ _ _ 7 . 5 A - -	368	132M
14	103.15	5095	2.08	56000	1 0 0		
13	110.94	5480	1.85	56000	1 1 2		
11	126.37	6242	1.70	56000	1 2 5		
10	140.77	6954	1.46	56000	1 4 0		
9.0	160.35	7921	1.34	56000	1 6 0		
8.1	178.07	8796	1.15	56000	1 8 0		
7.1	202.84	10020	1.06	56000	2 0 0		
6.4	225.49	11138	0.91	56000	2 2 5		
5.6	256.85	12688	0.84	56000	2 5 0		

NOTE
Other output speeds are available using 2 and 8 pole motors - Please contact our Application Engineers

SERIES F

SELECTION TABLES

GEARED MOTORS

7.5 kW

4 POLE

N2 R/MIN	i	M2 Nm	Fm	N	Unit Designation	Kg	Motor Sizes
Output Speed	Ratio	Output Torque	Service Factor	Overhung Load	Column Entry [1] Through [20] Spaces to be filled when entering order	Weight of base mount unit	
10	139.88	6910	2.37	62200	F 1 2 3 1 1 4 0 _ M _ _ _ _ 7 . 5 A - -	554	132M
9.6	151.08	7463	2.19	62200	1 6 0		
8.0	181.27	8954	1.83	62200	1 8 0		
7.4	195.79	9671	1.69	62200	2 0 0		
6.3	229.54	11338	1.45	62200	2 2 5		
5.8	247.92	12246	1.34	62200	2 5 0		
5.1	285.33	14094	1.17	62200	2 8 0		
4.7	308.18	15223	1.08	62200	3 1 5		

7.5 kW

6 POLE

143	6.77	484	1.17	7190	F 0 7 2 2 7 . 1 _ M _ _ _ _ 7 . 5 C - -	153	160M
103	9.38	672	1.17	7340	9 . 0		
92	10.54	755	1.17	7340	1 0 .		
84	11.59	831	1.17	7320	1 2 .		
64	15.13	1089	1.17	7090	1 4 .		
56	17.21	1238	1.08	6880	1 6 .		
139	6.96	499	2.34	9501	F 0 8 2 2 7 . 1 _ M _ _ _ _ 7 . 5 C - -	207	160M
98	9.87	708	2.34	10170	9 . 0		
89	10.96	784	2.34	10297	1 0 .		
80	12.19	877	2.22	10439	1 2 .		
62	15.76	1134	1.91	10687	1 4 .		
55	17.70	1270	1.78	10742	1 6 .		
45	21.70	1561	1.55	10735	2 0 .		
40	24.45	1753	1.41	10678	2 2 .		
34	28.46	2039	1.28	10503	2 5 .		
31	31.57	2258	1.16	10302	2 8 .		
28	34.55	2474	1.04	10000	3 2 .		
25	39.09	2805	0.97	9630	3 6 .		
22	44.13	3160	0.88	9090	4 0 .		
34	28.41	2043	2.07	29832	F 0 9 2 1 2 8 . _ M _ _ _ _ 7 . 5 C - -	261	160M
31	31.56	2264	1.87	29836	3 2 .		
26	36.69	2622	1.64	29789	3 6 .		
24	40.76	2908	1.48	29787	4 0 .		
22	44.58	3195	1.33	29787	4 5 .		
20	49.22	3528	1.20	29720	5 0 .		
17	57.58	4117	1.05	29700	5 6 .		
15	63.56	4550	0.95	29700	6 3 .		
14	67.71	4838	0.82	29700	7 1 .		
47	20.46	1479	3.94	43300	F 1 0 2 1 2 0 . _ M _ _ _ _ 7 . 5 C - -	337	160M
42	22.76	1643	3.77	43300	2 2 .		
37	25.77	1859	3.48	43300	2 5 .		
34	28.01	2031	3.15	43300	2 8 .		
31	31.16	2252	2.84	43300	3 2 .		
27	35.32	2539	2.85	43300	3 6 .		
24	39.25	2832	2.56	43300	4 0 .		
22	44.63	3204	2.00	43300	4 5 .		
19	51.19	3701	1.73	43300	5 0 .		
17	55.97	4036	1.80	43300	5 6 .		
15	64.49	4623	1.57	43300	6 3 .		
14	69.24	4976	1.24	43300	7 1 .		
13	74.39	5338	1.05	43300	8 0 .		
11	87.21	6246	1.16	43300	9 0 .		
10	93.70	6709	1.05	43300	1 0 0		
19	51.85	3829	2.02	49100	F 1 1 2 1 5 6 . _ M _ _ _ _ 7 . 5 C - -	433	160M
16	59.06	4361	2.02	50200	6 3 .		
4.2	229.54	16949	0.97	62200	F 1 2 3 1 2 2 5 _ M _ _ _ _ 7 . 5 C - -	583	160M
3.9	247.92	18306	0.90	62200	2 5 0		

NOTE
Other output speeds are available using 2 and 8 pole motors - Please contact our Application Engineers

SERIES F

SELECTION TABLES

GEARED MOTORS

11 kW

4 POLE

N2 R/MIN	i	M2 Nm	Fm	N	Unit Designation	Kg	Motor Sizes
Output Speed	Ratio	Output Torque	Service Factor	Overhung Load	Column Entry [1] Through [20] Spaces to be filled when entering order	Weight of base mount unit	
216	6.77	470	1.20	6030	F 0 7 2 2 7 . 1 _ M _ _ _ _ 1 1 . A - -	140	160M
156	9.38	652	1.20	6061	9 . 0		
139	10.54	733	1.20	6020	1 0 .		
126	11.59	807	1.20	5955	1 2 .		
96	15.13	1056	1.10	5633	1 4 .		
85	17.21	1200	1.02	5377	1 6 .		
210	6.96	486	2.41	8130	F 0 8 2 2 7 . 1 _ M _ _ _ _ 1 1 . A - -	194	160M
148	9.87	689	2.33	8582	9 . 0		
133	10.96	762	2.22	8689	1 0 .		
120	12.19	852	2.09	8784	1 2 .		
93	15.76	1103	1.79	8902	1 4 .		
83	17.70	1235	1.68	8927	1 6 .		
67	21.70	1508	1.46	8784	2 0 .		
60	24.45	1710	1.33	8654	2 2 .		
51	28.46	1993	1.20	8376	2 5 .		
46	31.57	2202	1.12	8135	2 8 .		
42	34.55	2419	1.03	7824	3 2 .		
37	39.09	2725	0.94	7335	3 6 .		
33	44.13	3082	0.85	6740	4 0 .		
129	11.35	794	3.76	29900	F 0 9 2 1 1 1 . _ M _ _ _ _ 1 1 . A - -	248	160M
115	12.68	888	3.53	29900	1 2 .		
100	14.66	1023	3.31	29900	1 4 .		
89	16.37	1144	3.10	29900	1 6 .		
83	17.58	1228	2.94	29900	1 8 .		
73	20.04	1406	2.71	29900	2 0 .		
64	22.70	1587	2.56	29900	2 2 .		
56	25.88	1812	2.36	29900	2 5 .		
51	28.41	1988	2.13	29867	2 8 .		
46	31.56	2205	1.92	29834	3 2 .		
40	36.69	2558	1.68	29800	3 6 .		
36	40.76	2836	1.52	29765	4 0 .		
33	44.58	3108	1.36	29755	4 5 .		
30	49.22	3431	1.24	29772	5 0 .		
25	57.58	4024	1.07	29725	5 6 .		
23	63.56	4442	0.97	29722	6 3 .		
81	18.07	1269	3.87	43200	F 1 0 2 1 1 8 . _ M _ _ _ _ 1 1 . A - -	342	160M
71	20.46	1436	3.59	43200	2 0 .		
64	22.76	1594	3.43	43200	2 2 .		
56	25.77	1804	3.17	43200	2 5 .		
52	28.01	1969	2.96	43200	2 8 .		
47	31.16	2185	2.76	43200	3 2 .		
41	35.32	2476	2.61	43200	3 6 .		
37	39.25	2746	2.44	43200	4 0 .		
33	44.63	3118	2.05	43200	4 5 .		
28	51.19	3597	1.78	43200	5 0 .		
26	55.97	3915	1.85	43200	5 6 .		
22	64.49	4515	1.61	43200	6 3 .		
21	69.24	4831	1.28	43200	7 1 .		
19	74.39	5211	1.08	43200	8 0 .		
17	87.21	6066	1.20	43200	9 0 .		
16	93.70	6540	1.08	43200	1 0 0		
28	51.85	3731	2.02	41400	F 1 1 2 1 5 6 . _ M _ _ _ _ 1 1 . A - -	420	160M
25	59.06	4249	2.02	42200	6 3 .		
32	45.60	3281	2.43	38900	F 1 1 3 1 4 5 . _ M _ _ _ _ 1 1 . A - -	407	160M
28	51.94	3737	2.43	39500	5 0 .		
26	55.67	4006	2.14	41500	5 6 .		
23	63.42	4563	2.14	42100	6 3 .		
20	72.26	5199	1.81	45200	7 1 .		
18	82.30	5922	1.79	46000	8 0 .		
16	90.56	6516	1.55	48700	9 0 .		
14	103.15	7422	1.43	50600	1 0 0		
13	110.94	7982	1.27	53000	1 1 2		
12	126.37	9093	1.17	55100	1 2 5		
10	140.77	10129	1.00	56000	1 4 0		
9.1	160.35	11538	0.92	56000	1 6 0		

NOTE

Other output speeds are available using 2 and 8 pole motors - Please contact our Application Engineers

SERIES F

SELECTION TABLES

GEARED MOTORS

11 kW

4 POLE

N2 R/MIN	i	M2 Nm	Fm	N	Unit Designation	Kg	Motor Sizes
Output Speed	Ratio	Output Torque	Service Factor	Overhung Load	Column Entry [1] Through [20] Spaces to be filled when entering order	Weight of base mount unit	
16	93.43	6769	2.41	54000	F 1 2 3 1 9 0 . _ M _ _ _ _ 1 1 . K - -	565	132M
14	100.91	7311	2.22	56100	1 0 0		
13	115.39	8360	1.95	59200	1 1 2		
12	124.63	9029	1.80	61400	1 2 5		
10	139.88	10134	1.62	62200	1 4 0		
9.6	151.08	10945	1.49	62200	1 6 0		
8.0	181.27	13133	1.25	62200	1 8 0		
7.4	195.79	14185	1.15	62200	2 0 0		
6.3	229.54	16630	0.99	62200	2 2 5		
5.8	247.92	17961	0.91	62200	2 5 0		
5.1	285.33	20672	0.80	62200	2 8 0		
16	93.43	6722	2.42	54000	F 1 2 3 1 9 0 . _ M _ _ _ _ 1 1 . A - -	570	160M
14	100.91	7261	2.23	56100	1 0 0		
13	115.39	8303	1.97	59200	1 1 2		
12	124.63	8967	1.81	61400	1 2 5		
10	139.88	10065	1.63	62200	1 4 0		
9.7	151.08	10871	1.50	62200	1 6 0		
8.1	181.27	13043	1.26	62200	1 8 0		
7.5	195.79	14087	1.16	62200	2 0 0		
6.4	229.54	16516	1.00	62200	2 2 5		
5.9	247.92	17838	0.92	62200	2 5 0		
5.1	285.33	20530	0.80	62200	2 8 0		

11 kW

6 POLE

139	6.96	732	1.60	8628	F 0 8 2 2 7 . 1 _ M _ _ _ _ 1 1 . C - -	221	160L
98	9.87	1038	1.60	8894	9 . 0		
89	10.96	1151	1.60	8893	1 0 .		
80	12.19	1286	1.52	8878	1 2 .		
62	15.76	1663	1.30	8675	1 4 .		
55	17.70	1863	1.21	8485	1 6 .		
45	21.70	2290	1.06	7970	2 0 .		
40	24.45	2571	0.96	7550	2 2 .		
34	28.46	2990	0.87	6850	2 5 .		
148	6.57	690	3.72	29900	F 0 9 2 1 6 . 3 _ M _ _ _ _ 1 1 . C - -	275	160L
139	7.00	737	3.59	29900	7 . 1		
124	7.85	827	3.41	29900	8 . 0		
110	8.81	930	3.21	29900	9 . 0		
96	10.13	1065	3.02	29900	1 0 .		
85	11.35	1198	2.83	29900	1 1 .		
77	12.68	1337	2.65	29900	1 2 .		
66	14.66	1542	2.49	29900	1 4 .		
59	16.37	1722	2.33	29900	1 6 .		
55	17.58	1855	2.20	29900	1 8 .		
48	20.04	2117	2.00	29900	2 0 .		
43	22.70	2393	1.80	29900	2 2 .		
37	25.88	2727	1.58	29900	2 5 .		
34	28.41	2997	1.41	29764	2 8 .		
31	31.56	3320	1.28	29772	3 2 .		
26	36.69	3846	1.12	29700	3 6 .		
24	40.76	4265	1.01	29700	4 0 .		
22	44.58	4686	0.90	29700	4 5 .		
20	49.22	5174	0.82	29600	5 0 .		
84	11.48	1219	3.76	43200	F 1 0 2 1 1 1 . _ M _ _ _ _ 1 1 . C - -	356	160L
78	12.39	1314	3.59	43200	1 2 .		
67	14.46	1529	3.35	43200	1 4 .		
62	15.61	1653	3.20	43200	1 6 .		
53	18.07	1919	2.90	43200	1 8 .		
47	20.46	2169	2.69	43200	2 0 .		
42	22.76	2410	2.57	43200	2 2 .		
37	25.77	2727	2.38	43200	2 5 .		
34	28.01	2980	2.15	43200	2 8 .		
31	31.16	3303	1.94	43200	3 2 .		
27	35.32	3724	1.95	43200	3 6 .		
24	39.25	4158	1.75	43200	4 0 .		
22	44.63	4700	1.36	43200	4 5 .		
19	51.19	5429	1.18	43200	5 0 .		
17	55.97	5920	1.22	43200	5 6 .		
15	64.49	6780	1.07	43200	6 3 .		
14	69.24	7299	0.85	43200	7 1 .		
24	45.04	4314	2.46	45300	F 1 1 2 1 4 0 . _ M _ _ _ _ 1 1 . C - -	447	160L
22	51.30	4878	1.88	46100	4 5 .		
19	50.96	5556	1.78	45900	5 0 .		
19	51.85	5615	1.37	49100	5 6 .		
16	59.06	6396	1.37	50200	6 3 .		
18	53.75	5821	1.96	56300	F 1 2 2 1 5 6 . _ M _ _ _ _ 1 1 . C - -	602	160L
17	58.06	6288	1.96	57300	6 3 .		

NOTE
Other output speeds are available using 2 and 8 pole motors - Please contact our Application Engineers

SERIES F

SELECTION TABLES

GEARED MOTORS

15 kW

4 POLE

N2 R/MIN	i	M2 Nm	Fm	N	Unit Designation	Kg	Motor Sizes
Output Speed	Ratio	Output Torque	Service Factor	Overhung Load	Column Entry [1] Through [20] Spaces to be filled when entering order	Weight of base mount unit	
216	6.77	641	0.88	5150	F 0 7 2 2 7 . 1 _ M _ _ _ _ 1 5 . A - -	157	160L
156	9.38	890	0.88	4840	9 . 0		
139	10.54	1000	0.88	4650	1 0 .		
126	11.59	1100	0.88	4450	1 2 .		
96	15.13	1440	0.81	3670	1 4 .		
210	6.96	662	1.77	7457	F 0 8 2 2 7 . 1 _ M _ _ _ _ 1 5 . A - -	211	160L
148	9.87	940	1.71	7626	9 . 0		
133	10.96	1040	1.62	7626	1 0 .		
120	12.19	1163	1.53	7601	1 2 .		
93	15.76	1504	1.32	7376	1 4 .		
83	17.70	1685	1.23	7201	1 6 .		
67	21.70	2057	1.07	6688	2 0 .		
60	24.45	2332	0.97	6285	2 2 .		
51	28.46	2717	0.88	5620	2 5 .		
46	31.57	3003	0.82	5070	2 8 .		
222	6.57	623	3.64	29900	F 0 9 2 1 6 . 3 _ M _ _ _ _ 1 5 . A - -	265	160L
209	7.00	666	3.51	29900	7 . 1		
186	7.85	747	3.33	29900	8 . 0		
166	8.81	840	3.14	29900	9 . 0		
144	10.13	964	2.95	29889	1 0 .		
129	11.35	1083	2.76	29889	1 1 .		
115	12.68	1211	2.59	29889	1 2 .		
100	14.66	1395	2.43	29876	1 4 .		
89	16.37	1560	2.28	29885	1 6 .		
83	17.58	1675	2.15	29870	1 8 .		
73	20.04	1917	1.99	29869	2 0 .		
64	22.70	2165	1.88	29860	2 2 .		
56	25.88	2471	1.73	29840	2 5 .		
51	28.41	2710	1.56	29842	2 8 .		
46	31.56	3007	1.41	29785	3 2 .		
40	36.69	3489	1.24	29727	3 6 .		
36	40.76	3867	1.11	29687	4 0 .		
33	44.58	4239	1.00	29672	4 5 .		
30	49.22	4678	0.91	29700	5 0 .		
127	11.48	1094	3.69	43200	F 1 0 2 1 1 1 . _ M _ _ _ _ 1 5 . A - -	355	160L
118	12.39	1183	3.52	43200	1 2 .		
101	14.46	1377	3.29	43200	1 4 .		
94	15.61	1486	3.14	43200	1 6 .		
81	18.07	1725	2.85	43200	1 8 .		
71	20.46	1952	2.64	43200	2 0 .		
64	22.76	2167	2.52	43200	2 2 .		
56	25.77	2452	2.34	43200	2 5 .		
52	28.01	2675	2.17	43200	2 8 .		
47	31.16	2969	2.03	43200	3 2 .		
41	35.32	3364	1.92	43200	3 6 .		
37	39.25	3732	1.79	43200	4 0 .		
33	44.63	4237	1.51	43200	4 5 .		
28	51.19	4889	1.31	43200	5 0 .		
26	55.97	5320	1.36	43200	5 6 .		
22	64.49	6136	1.18	43200	6 3 .		
21	69.24	6565	0.94	43200	7 1 .		
17	87.21	8244	0.88	43100	9 0 .		
32	45.04	4434	1.92	38000	F 1 1 2 1 4 5 . _ M _ _ _ _ 1 5 . A - -	439	160L
28	51.30	5051	1.92	38500	5 0 .		
28	51.85	5105	1.49	41400	5 6 .		
25	59.06	5815	1.49	42200	6 3 .		
27	53.75	5292	2.12	47400	F 1 2 2 1 5 6 . _ M _ _ _ _ 1 5 . A - -	594	160L
25	58.60	5375	2.12	48100	6 3 .		
27	53.75	5292	2.12	47400	F 1 2 3 1 7 1 . _ M _ _ _ _ 1 5 . A - -	594	160L
19	77.95	7674	2.11	50200	8 0 .		
16	93.43	9199	1.77	54000	9 0 .		
14	100.91	9935	1.63	56100	1 0 0		
13	115.39	11361	1.44	59200	1 1 2		
12	124.63	12270	1.33	61400	1 2 5		
10	139.88	13772	1.19	62200	1 4 0		
9.6	151.08	14874	1.10	62200	1 6 0		
8.0	181.27	17847	0.92	62200	1 8 0		
7.4	195.79	19276	0.85	62200	2 0 0		

NOTE

Other output speeds are available using 2 and 8 pole motors - Please contact our Application Engineers

SERIES F

SELECTION TABLES

GEARED MOTORS

15 kW

6 POLE

N2 R/MIN	i	M2 Nm	Fm	N	Unit Designation	Kg	Motor Sizes
Output Speed	Ratio	Output Torque	Service Factor	Overhung Load	Column Entry 1 Through 20 Spaces to be filled when entering order	Weight of base mount unit	
191	5.08	729	3.04	29900	F 0 9 2 1 5 . 0 _ M _ _ _ _ 1 5 . C - -	294	180L
148	6.57	942	2.73	29888	6 . 3		
139	7.00	1006	2.63	29888	7 . 1		
124	7.85	1128	2.50	29888	8 . 0		
110	8.81	1268	2.36	29888	9 . 0		
96	10.13	1452	2.22	29885	1 0 .		
85	11.35	1633	2.07	29870	1 1 .		
77	12.68	1823	1.95	29880	1 2 .		
66	14.66	2103	1.83	29860	1 4 .		
59	16.37	2349	1.71	29860	1 6 .		
55	17.58	2529	1.62	29836	1 8 .		
48	20.04	2887	1.47	29827	2 0 .		
43	22.70	3264	1.32	29827	2 2 .		
37	25.88	3719	1.16	29805	2 5 .		
34	28.41	4087	1.04	29687	2 8 .		
31	31.56	4528	0.94	29700	3 2 .		
26	36.69	5244	0.82	29600	3 6 .		
190	5.11	733	3.49	43500	F 1 0 2 1 5 . 0 _ M _ _ _ _ 1 5 . C - -	380	180L
151	6.43	922	3.49	43500	6 . 3		
136	7.13	1025	3.49	43500	7 . 1		
125	7.76	1115	3.39	43500	8 . 0		
110	8.81	1270	3.18	43500	9 . 0		
99	9.77	1402	3.04	43500	1 0 .		
84	11.48	1654	2.77	43500	1 1 .		
78	12.39	1762	2.65	43500	1 2 .		
67	14.46	2075	2.47	43500	1 4 .		
62	15.61	2243	2.36	43400	1 6 .		
53	18.07	2603	2.14	43400	1 8 .		
47	20.46	2943	1.98	43400	2 0 .		
42	22.76	3270	1.89	43400	2 2 .		
37	25.77	3699	1.75	43400	2 5 .		
34	28.01	4042	1.58	43200	2 8 .		
31	31.16	4481	1.43	43200	3 2 .		
27	35.32	5052	1.43	43200	3 6 .		
24	39.25	5635	1.29	43200	4 0 .		
22	44.63	6376	1.00	43200	4 5 .		
19	51.19	7365	0.87	43200	5 0 .		
17	55.97	8032	0.90	43200	5 6 .		
24	39.83	5882	1.80	40500	F 1 1 2 1 4 0 . _ M _ _ _ _ 1 5 . C - -	496	180L
22	45.04	6652	1.30	45300	4 5 .		
19	51.30	7576	1.30	46100	5 0 .		
19	51.85	7657	1.01	49100	5 6 .		
16	59.06	8722	1.01	50200	6 3 .		
21	45.60	6670	1.19	42500	F 1 1 3 1 4 5 . _ M _ _ _ _ 1 5 . C - -	426	180L
18	51.94	7597	1.19	46000	5 0 .		
17	55.67	8143	1.05	48000	5 6 .		
15	63.42	9276	1.05	48700	6 3 .		
13	72.26	10569	0.99	52000	7 1 .		
12	82.30	12038	0.87	55100	8 0 .		
22	45.60	6461	2.18	48900	F 1 2 2 1 4 5 . _ M _ _ _ _ 1 5 . C - -	651	180L
21	47.26	6979	2.18	49600	5 0 .		
18	53.75	7938	1.43	56300	5 6 .		
17	68.06	8594	1.43	57300	6 3 .		
13	72.17	10556	1.53	59200	F 1 1 3 1 7 1 . _ M _ _ _ _ 1 5 . C - -		
12	77.95	11401	1.42	61400	8 0 .		
10	93.43	13666	1.19	62200	9 0 .		
9	100.91	14760	1.10	62200	1 0 0		
8	115.39	16878	0.96	62200	1 1 2		

NOTE

Other output speeds are available using 2 and 8 pole motors - Please contact our Application Engineers

SERIES F

SELECTION TABLES

GEARED MOTORS

18.5 kW

4 POLE

N2 R/MIN	i	M2 Nm	Fm	N	Unit Designation	Kg	
Output Speed	Ratio	Output Torque	Service Factor	Overhung Load	Column Entry <input type="checkbox"/> 1 Through <input type="checkbox"/> 20 Spaces to be filled when entering order	Weight of base mount unit	Motor Sizes
287	5.08	597	3.28	29785	F 0 9 2 1 5 . 0 _ M _ _ _ _ 1 8 . A - -	292	180M
222	6.57	769	2.95	29900	6 . 3		
209	7.00	822	2.85	29891	7 . 1		
186	7.85	922	2.70	29874	8 . 0		
166	8.81	1036	2.55	29840	9 . 0		
144	10.13	1190	2.39	29879	1 0 .		
129	11.35	1336	2.24	29879	1 1 .		
115	12.68	1494	2.10	29879	1 2 .		
100	14.66	1720	1.97	29855	1 4 .		
89	16.37	1924	1.85	29872	1 6 .		
83	17.58	2066	1.75	29844	1 8 .		
73	20.04	2364	1.61	29842	2 0 .		
64	22.70	2670	1.52	29825	2 2 .		
56	25.88	3047	1.40	29787	2 5 .		
51	28.41	3343	1.27	29821	2 8 .		
46	31.56	3709	1.14	29742	3 2 .		
40	36.69	4303	1.00	29663	3 6 .		
36	40.76	4770	0.90	29619	4 5 .		
33	44.58	5228	0.81	29600	5 0 .		
205	7.13	839	3.81	43500	F 1 0 2 1 7 . 1 _ M _ _ _ _ 1 8 . A - -	378	180M
188	7.76	913	3.66	43500	8 . 0		
166	8.81	1036	3.43	43500	9 . 0		
149	9.77	1146	3.29	43500	1 0 .		
127	11.48	1349	2.99	43500	1 1 .		
118	12.39	1459	2.86	43500	1 2 .		
101	14.46	1698	2.67	43500	1 4 .		
94	15.61	1833	2.55	43400	1 6 .		
81	18.07	2127	2.31	43400	1 8 .		
71	20.46	2407	2.14	43400	2 0 .		
64	22.76	2672	2.05	43400	2 2 .		
56	25.77	3025	1.89	43400	2 5 .		
52	28.01	3300	1.76	43300	2 8 .		
47	31.16	3662	1.65	43300	3 2 .		
41	35.32	4150	1.56	43300	3 6 .		
37	39.25	4603	1.45	43300	4 0 .		
33	44.63	5226	1.22	43200	4 5 .		
28	51.19	6030	1.06	43200	5 0 .		
26	55.97	6561	1.10	43100	5 6 .		
22	64.49	7568	0.96	43100	6 3 .		
41	34.96	4260	2.38	32100	F 1 1 2 1 3 6 . _ M _ _ _ _ 1 8 . K - -	48	160L
36	39.83	4853	2.19	33300	4 0 .		
32	45.04	5488	1.55	38000	4 5 .		
28	51.30	6251	1.55	38500	5 0 .		
28	51.85	6318	1.21	41400	5 6 .		
25	59.06	7196	1.21	42200	6 3 .		
42	34.96	4202	2.41	32100	F 1 1 2 1 3 6 . _ M _ _ _ _ 1 8 . A - -	469	180M
37	39.83	4787	2.22	33300	4 0 .		
33	45.04	5413	1.57	38000	4 5 .		
29	51.30	6166	1.57	38500	5 0 .		
28	51.85	6232	1.22	41400	5 6 .		
25	59.06	7098	1.22	42200	6 3 .		
32	45.60	5556	1.43	38900	F 1 1 3 1 4 5 . _ M _ _ _ _ 1 8 . K - -	435	160L
28	51.94	6329	1.43	39500	5 0 .		
26	55.67	6783	1.26	41500	5 6 .		
23	63.42	7727	1.26	42100	6 3 .		
20	72.76	8805	1.07	45200	7 1 .		
18	82.30	10028	1.06	46000	8 0 .		
16	90.56	11034	0.92	48700	9 0 .		
14	103.15	12568	0.84	50600	1 0 0		
32	45.60	5481	1.45	38900	F 1 1 3 1 4 5 . _ M _ _ _ _ 1 8 . A - -	456	180M
28	51.94	6233	1.45	39500	5 0 .		
26	55.67	6691	1.28	41500	5 6 .		
23	63.42	7622	1.28	42100	6 3 .		
20	72.76	8685	1.08	45200	7 1 .		
18	82.30	9891	1.07	46000	8 0 .		
16	90.56	11884	0.93	48700	9 0 .		
14	103.15	12397	0.86	50600	1 0 0		
27	53.75	6549	1.71	47400	F 1 2 2 1 5 6 . _ M _ _ _ _ 1 8 . K - -	603	160L
25	58.06	7074	1.71	48100	6 3 .		
27	53.75	6460	1.74	47400	F 1 2 2 1 5 6 . _ M _ _ _ _ 1 8 . A - -	624	180M
25	58.06	6978	1.74	48100	6 3 .		

NOTE

Other output speeds are available using 2 and 8 pole motors - Please contact our Application Engineers

SERIES F

SELECTION TABLES

GEARED MOTORS

18.5 kW

4 POLE

N2 R/MIN	i	M2 Nm	Fm	N	Unit Designation	Kg	Motor Sizes
Output Speed	Ratio	Output Torque	Service Factor	Overhung Load	Column Entry [1] Through [20] Spaces to be filled when entering order	Weight of base mount unit	
25	58.27	7100	2.28	43800	F 1 2 3 1 5 6 . _ _ 1 6 0 L B - 4 - -	598	160L
23	62.94	7669	2.10	45600	6 3 .		
20	72.17	8794	1.85	48200	7 1 .		
19	77.95	9598	1.70	50200	8 0 .		
16	93.43	11384	1.43	54000	9 0 .		
15	100.91	12295	1.32	56100	1 0 0		
13	115.39	14060	1.16	59200	1 1 2		
12	124.63	15186	1.07	61400	1 2 5		
11	139.88	17044	0.96	62200	1 4 0		
9.7	151.08	18408	0.89	62200	1 6 0		
25	58.27	7003	2.31	43800	F 1 2 3 1 5 6 . _ _ 1 8 0 M - 4 - -	619	180M
23	62.94	7565	2.13	45600	6 3 .		
20	72.17	8674	1.87	48200	7 1 .		
19	77.95	9369	1.73	50200	8 0 .		
16	93.43	11229	1.45	54000	9 0 .		
15	100.91	12128	1.34	56100	1 0 0		
13	115.39	13868	1.18	59200	1 1 2		
12	124.63	14979	1.09	61400	1 2 5		
11	139.88	16812	0.97	62200	1 4 0		
9.7	151.08	18518	0.90	62200	1 6 0		

18.5 kW

6 POLE

194	5.08	885	2.51	29900	F 0 9 2 1 5 . 0 _ M _ _ _ _ 1 8 . C - -	310	200L
150	6.57	1144	2.25	29877	6 . 3		
141	7.00	1222	2.17	29877	7 . 1		
126	7.85	1370	2.06	29877	8 . 0		
112	8.81	1540	1.94	29877	9 . 0		
97	10.13	1764	1.82	29872	1 0 .		
87	11.35	1984	1.71	29844	1 1 .		
78	12.68	2214	1.60	29862	1 2 .		
67	14.66	2554	1.50	29825	1 4 .		
60	16.37	2853	1.41	29825	1 6 .		
56	17.58	3072	1.33	29781	1 8 .		
49	20.04	3506	1.21	29763	2 0 .		
43	22.70	3964	1.09	29763	2 2 .		
38	25.88	4518	0.95	29723	2 5 .		
35	28.41	4964	0.85	29619	2 8 .		
190	5.11	904	2.83	43500	F 1 0 2 1 5 . 0 _ M _ _ _ _ 1 8 . C - -	395	200L
151	6.43	1138	2.83	43500	6 . 3		
136	7.13	1265	2.83	43500	7 . 1		
125	7.76	1375	2.75	43500	8 . 0		
110	8.81	1567	2.58	43500	9 . 0		
99	9.77	1729	2.47	43500	1 0 .		
84	11.48	2040	2.24	43500	1 1 .		
78	12.39	2198	2.15	43500	1 2 .		
67	14.46	2559	2.00	43500	1 4 .		
62	15.61	2767	1.91	43400	1 6 .		
53	18.07	3211	1.73	43400	1 8 .		
47	20.46	3630	1.61	43400	2 0 .		
42	22.76	4033	1.53	43400	2 2 .		
37	25.77	4563	1.42	43300	2 5 .		
34	28.01	4986	1.28	43300	2 8 .		
31	31.16	5527	1.16	43300	3 2 .		
27	35.32	6232	1.16	43200	3 6 .		
24	39.25	6949	1.04	43200	4 0 .		
22	44.63	7864	0.81	43100	4 5 .		
24	39.83	7292	1.46	40500	F 1 1 2 1 4 0 . _ M _ _ _ _ 1 8 . M - -	505	180L
21	45.04	8246	1.05	45300	4 5 .		
19	51.30	9392	1.05	46100	5 0 .		
19	51.85	9493	0.81	49100	5 6 .		
16	59.06	10813	0.81	50200	6 3 .		
25	39.83	7144	1.49	40500	F 1 1 2 1 4 0 . _ M _ _ _ _ 1 8 . C - -	510	200L
22	45.04	8079	1.07	45300	4 5 .		
19	51.30	9201	1.07	46100	5 0 .		
19	51.85	9300	0.83	49100	5 6 .		
17	59.06	10593	0.83	50200	6 3 .		
25	38.46	7041	2.28	44400	F 1 2 2 1 4 0 . _ M _ _ _ _ 1 8 . M - -	660	180L
22	43.75	8010	1.76	48900	4 5 .		
20	47.26	8652	1.76	49600	5 0 .		
18	53.75	9841	1.16	56300	5 6 .		
17	58.06	10630	1.16	57300	6 3 .		
26.0	38.46	6898	2.33	44400	F 1 2 2 1 4 0 . _ M _ _ _ _ 1 8 . C - -	665	200L
23.0	43.75	7847	1.80	48900	4 5 .		
21.0	47.26	8477	1.80	49600	5 0 .		
18.0	53.75	9641	1.18	56300	5 6 .		
17.0	58.06	10414	1.18	57300	6 3 .		

NOTE
Other output speeds are available using 2 and 8 pole motors - Please contact our Application Engineers

SERIES F

SELECTION TABLES

GEARED MOTORS

22 kW

4 POLE

N2 R/MIN	i	M2 Nm	Fm	N	Unit Designation	Kg	Motor Sizes
Output Speed	Ratio	Output Torque	Service Factor	Overhung Load	Column Entry 1 Through 20 Spaces to be filled when entering order	Weight of base mount unit	
287	5.08	710	2.76	29670	F 0 9 2 1 5 . 0 _ M _ _ _ _ 2 2 . A - -	328	180L
222	6.57	915	2.48	29900	6 . 3		
209	7.00	977	2.39	29882	7 . 1		
186	7.85	1096	2.27	29848	8 . 0		
166	8.81	1232	2.14	29780	9 . 0		
144	10.13	1415	2.01	29870	1 0 .		
129	11.35	1589	1.88	29870	1 1 .		
115	12.68	1777	1.77	29870	1 2 .		
100	14.66	2046	1.66	29835	1 4 .		
89	16.37	2288	1.55	29859	1 6 .		
83	17.58	2457	1.47	29818	1 8 .		
73	20.04	2812	1.35	29815	2 0 .		
64	22.70	3175	1.28	29790	2 2 .		
56	25.88	3624	1.18	29735	2 5 .		
51	28.41	3976	1.07	29800	2 8 .		
46	31.56	4411	0.96	29700	3 2 .		
40	36.69	5117	0.84	29600	3 6 .		
287	5.11	712	3.59	43500	F 1 0 2 1 5 . 0 _ M _ _ _ _ 2 2 . A - -	414	180L
228	6.43	893	3.38	43500	6 . 3		
205	7.13	995	3.21	43500	7 . 1		
188	7.76	1082	3.09	43500	8 . 0		
166	8.81	1228	2.90	43500	9 . 0		
149	9.77	1359	2.77	43500	1 0 .		
127	11.48	1599	2.53	43500	1 1 .		
118	12.39	1729	2.41	43500	1 2 .		
101	14.46	2013	2.25	43500	1 4 .		
94	15.61	2172	2.15	43400	1 6 .		
81	18.07	2521	1.95	43400	1 8 .		
71	20.46	2853	1.80	43400	2 0 .		
64	22.76	3167	1.73	43400	2 2 .		
56	25.77	3585	1.60	43400	2 5 .		
52	28.01	3911	1.49	43300	2 8 .		
47	31.16	4340	1.39	43300	3 2 .		
41	35.32	4918	1.31	43200	3 6 .		
37	39.25	5455	1.23	43200	4 0 .		
33	44.63	6193	1.03	43200	4 5 .		
28	51.19	7146	0.90	43200	5 0 .		
26	55.97	7776	0.93	43100	5 6 .		
22	64.49	8969	0.81	43100	6 3 .		
52	28.40	4059	2.49	29100	F 1 1 2 1 2 8 . _ M _ _ _ _ 2 2 . A - -	486	180L
45	32.34	4622	2.21	30700	3 2 .		
42	34.96	4997	2.03	32100	3 6 .		
37	39.83	5693	1.87	33300	4 0 .		
33	45.04	6437	1.32	38000	4 5 .		
29	51.30	7332	1.32	38500	5 0 .		
28	51.85	7411	1.03	41400	5 6 .		
25	59.06	8441	1.03	42200	6 3 .		
32	45.60	6517	1.22	38900	F 1 1 3 1 4 5 . _ M _ _ _ _ 2 2 . A - -		
28	51.94	7424	1.22	39500	5 0 .		
26	55.67	7957	1.08	41500	5 6 .		
23	63.42	9064	1.08	42100	6 3 .		
20	72.26	10328	0.91	45200	7 1 .		
18	82.30	11723	0.90	46000	8 0 .		
34	43.75	6253	2.18	40900	F 1 2 2 1 4 5 . _ M _ _ _ _ 2 2 . A - -	641	180L
31	47.26	6755	2.18	41300	5 0 .		
27	53.75	7682	1.46	47400	5 6 .		
25	58.06	8298	1.46	48100	6 3 .		
33	44.96	6426	2.47	39100	F 1 2 3 1 4 5 . _ M _ _ _ _ 2 2 . A - -	636	180L
30	48.56	6940	2.31	40500	5 0 .		
25	58.27	8328	1.94	43800	5 6 .		
23	62.94	8996	1.79	45600	6 3 .		
20	72.17	10315	1.57	48200	7 1 .		
19	77.95	11141	1.45	50200	8 0 .		
16	93.43	13353	1.12	54000	9 0 .		
15	100.91	14423	1.13	56100	1 0 0		
13	115.39	16492	0.99	59200	1 1 2		
12	124.63	17813	0.91	61400	1 2 5		
11	139.88	19992	0.82	62200	1 4 0		

NOTE
Other output speeds are available using 2 and 8 pole motors - Please contact our Application Engineers

SERIES F

SELECTION TABLES

GEARED MOTORS

22 kW

6 POLE

N2 R/MIN	i	M2 Nm	Fm	N	Unit Designation	Kg	Motor Sizes
Output Speed	Ratio	Output Torque	Service Factor	Overhung Load	Column Entry [1] Through [20] Spaces to be filled when entering order	Weight of base mount unit	
193	5.08	1058	2.10	29900	F 0 9 2 1 5 . 0 _ M _ _ _ _ 2 2 . C - -	329	200L
149	6.57	1367	1.88	29867	6 . 3		
140	7.00	1460	1.81	29867	7 . 1		
125	7.85	1638	1.72	29867	8 . 0		
111	8.81	1841	1.62	29867	9 . 0		
97	10.13	2109	1.53	29859	1 0 .		
86	11.35	2372	1.43	29818	1 1 .		
77	12.68	2647	1.34	29845	1 2 .		
67	14.66	3053	1.26	29790	1 4 .		
60	16.37	3410	1.18	29790	1 6 .		
56	17.58	3672	1.11	29726	1 8 .		
49	20.04	4191	1.01	29700	2 0 .		
43	22.70	4739	0.91	29700	2 2 .		
190	5.11	1076	2.38	43500	F 1 0 2 1 5 . 0 _ M _ _ _ _ 2 2 . C - -	415	200L
151	6.43	1353	2.38	43500	6 . 3		
136	7.13	1504	2.38	43500	7 . 1		
125	7.76	1636	2.31	43500	8 . 0		
110	8.81	1863	2.17	43500	9 . 0		
99	9.77	2056	2.08	43500	1 0 .		
84	11.48	2426	1.89	43500	1 1 .		
78	12.39	2614	1.80	43500	1 2 .		
67	14.46	3043	1.69	43500	1 4 .		
62	15.61	3290	1.61	43400	1 6 .		
53	18.07	3818	1.46	43400	1 8 .		
47	20.46	4317	1.35	43400	2 0 .		
42	22.76	4796	1.29	43400	2 2 .		
37	25.77	5426	1.19	43300	2 5 .		
25	39.83	8539	1.24	40500	F 1 1 2 1 4 0 . _ M _ _ _ _ 2 2 . C - -	530	200L
22	45.04	9656	0.90	45300	4 5 .		
19	51.30	10998	0.90	46100	5 0 .		
25	38.46	8245	1.95	44400	F 1 2 2 1 4 0 . _ M _ _ _ _ 2 2 . C - -	685	200L
22	43.75	9379	1.50	48900	4 5 .		
21	47.26	10132	1.50	49600	5 0 .		
18	53.75	11523	0.99	56300	5 6 .		
17	58.06	12447	0.99	57300	6 3 .		

30 kW

4 POLE

289	5.08	961	2.04	29408	F 0 9 2 1 5 . 0 _ M _ _ _ _ 3 0 . A - -	350	200L
224	6.57	1239	1.83	29900	6 . 3		
210	7.00	1323	1.77	29863	7 . 1		
187	7.85	1485	1.68	29790	8 . 0		
167	8.81	1669	1.58	29643	9 . 0		
145	10.13	1916	1.49	29848	1 0 .		
130	11.35	2152	1.39	29848	1 1 .		
116	12.68	2407	1.30	29848	1 2 .		
100	14.66	2771	1.22	29788	1 4 .		
90	16.37	3098	1.15	29829	1 6 .		
84	17.58	3327	1.08	29759	1 8 .		
73	20.04	3808	1.00	29753	2 0 .		
65	22.70	4301	0.95	29710	2 2 .		
57	25.88	4909	0.87	29615	2 5 .		
287	5.11	968	2.64	43500	F 1 0 2 1 5 . 0 _ M _ _ _ _ 3 0 . A - -	350	200L
228	6.43	1214	2.49	43500	6 . 3		
205	7.13	1352	2.37	43500	7 . 1		
188	7.76	1470	2.27	43500	8 . 0		
166	8.81	1669	2.13	43500	9 . 0		
149	9.77	1847	2.04	43500	1 0 .		
127	11.48	2173	1.86	43500	1 1 .		
118	12.39	2350	1.77	43500	1 2 .		
101	14.46	2735	1.66	43500	1 4 .		
94	15.61	2952	1.58	43400	1 6 .		
81	18.07	3426	1.43	43400	1 8 .		
71	20.46	3877	1.33	43300	2 0 .		
64	22.76	4304	1.27	43300	2 2 .		
56	25.77	4872	1.18	43300	2 5 .		
72	20.46	4001	2.24	26100	F 1 1 2 1 2 0 . _ M _ _ _ _ 3 0 . K - -	506	180L
65	22.42	4385	2.21	26600	2 2 .		
57	25.54	4995	1.92	28300	2 5 .		
52	28.40	5554	1.82	29100	2 8 .		
45	32.34	6325	1.62	30700	3 2 .		
42	34.96	6837	1.48	32100	3 6 .		
37	39.83	7789	1.36	33300	4 0 .		
33	45.04	8808	0.97	38000	4 5 .		
39	51.30	10032	0.97	38300	5 0 .		

NOTE

Other output speeds are available using 2 and 8 pole motors - Please contact our Application Engineers

SERIES F

SELECTION TABLES

GEARED MOTORS

30 kW

4 POLE

N2 R/MIN	i	M2 Nm	Fm	N	Unit Designation	Kg	Motor Sizes
Output Speed	Ratio	Output Torque	Service Factor	Overhung Load	Column Entry <input type="checkbox"/> 1 Through <input type="checkbox"/> 20 Spaces to be filled when entering order	Weight of base mount unit	
72	20.46	3974	2.26	26100	F 1 1 2 1 2 0 . _ M _ _ _ _ 3 0 . A - -	525	200L
66	22.42	4355	2.22	26600	2 2 .		
58	25.54	4961	1.92	28300	2 5 .		
52	28.40	5516	1.83	29100	2 8 .		
46	32.34	6282	1.63	30700	3 2 .		
42	34.96	6791	1.49	32100	3 6 .		
37	39.83	7736	1.37	33300	4 0 .		
33	45.04	8748	0.97	38000	4 5 .		
39	51.30	9964	0.97	38300	5 0 .		
32	45.60	8918	0.89	38900	F 1 1 3 1 4 5 . _ M _ _ _ _ 3 0 . K - -	493	180L
28	51.94	10158	0.89	39500	5 0 .		
41	35.61	6964	2.22	35200	F 1 2 2 1 3 6 . _ M _ _ _ _ 3 0 . K - -	661	180L
38	38.46	7521	2.12	36300	4 0 .		
33	43.75	8556	1.60	40900	4 5 .		
31	47.26	9242	1.60	41300	5 0 .		
27	53.75	10572	1.07	47400	5 6 .		
25	58.06	11354	1.07	48100	6 3 .		
41	35.61	6917	2.24	35200	F 1 2 2 1 3 6 . _ M _ _ _ _ 3 0 . A - -	680	200L
38	38.46	7470	2.14	36300	4 0 .		
34	43.75	8498	1.61	40900	4 5 .		
31	47.26	9180	1.61	41300	5 0 .		
27	53.75	10440	1.08	47400	5 6 .		
25	58.06	11277	1.08	48100	6 3 .		
33	44.96	8793	1.81	39100	F 1 2 3 1 4 5 . _ M _ _ _ _ 3 0 . K - -	656	180L
30	48.56	9497	1.69	40500	5 0 .		
25	58.27	11395	1.42	43800	5 6 .		
23	62.94	12309	1.31	45600	6 3 .		
20	72.17	14114	1.15	48200	7 1 .		
19	77.95	15244	1.06	50200	8 0 .		
16	93.43	18271	0.89	54000	9 0 .		
15	100.91	19734	0.82	56100	1 0 0		
33	44.96	8733	1.82	39100	F 1 2 3 1 4 5 . _ M _ _ _ _ 3 0 . A - -	686	200L
30	48.56	9432	1.70	40500	5 0 .		
25	58.27	11318	1.43	43800	5 6 .		
23	62.94	12225	1.32	45600	6 3 .		
20	72.17	14018	1.16	48200	7 1 .		
19	77.95	15141	1.07	50200	8 0 .		
16	93.43	18148	0.90	54000	9 0 .		
15	100.91	19600	0.83	56100	1 0 0		

30 kW

6 POLE

194	5.08	1436	1.55	29900	F 0 9 2 1 5 . 0 _ M _ _ _ _ 3 0 . C - -	412	225M
150	6.57	1855	1.39	29844	6 . 3		
141	7.00	1981	1.34	29844	7 . 1		
126	7.85	2222	1.27	29844	8 . 0		
112	8.81	2497	1.20	29844	9 . 0		
97	10.13	2861	1.13	29829	1 0 .		
87	11.35	3218	1.05	29759	1 1 .		
78	12.68	3591	0.99	29805	1 2 .		
67	14.66	4143	0.93	29710	1 4 .		
60	16.37	4627	0.87	29710	1 6 .		
56	17.58	4982	0.82	29600	1 8 .		
190	5.11	1459	1.75	43500	F 1 0 2 1 5 . 0 _ M _ _ _ _ 3 0 . C - -	500	225M
151	6.43	1836	1.75	43500	6 . 3		
136	7.13	2041	1.75	43500	7 . 1		
125	7.76	2219	1.70	43500	8 . 0		
110	8.81	2528	1.60	43500	9 . 0		
99	9.77	2790	1.53	43500	1 0 .		
84	11.48	3291	1.39	43500	1 1 .		
78	12.39	3547	1.33	43500	1 2 .		
67	14.46	4128	1.24	43500	1 4 .		
62	15.61	4464	1.18	43400	1 6 .		
53	18.07	5180	1.07	43400	1 8 .		
47	20.46	5857	1.00	43400	2 0 .		
42	22.76	6506	0.95	43400	2 2 .		
37	25.77	7361	0.88	43300	2 5 .		
25.0	39.83	11644	0.91	40500	F 1 1 2 1 4 0 . _ M _ _ _ _ 3 0 . M - -	545	200M
25.0	39.83	11585	0.92	40500	F 1 1 2 1 4 0 . _ M _ _ _ _ 3 0 . C - -	584	225M
25.0	38.46	11244	1.43	44400	F 1 2 2 1 4 0 . _ M _ _ _ _ 3 0 . M - -	700	200M
22.0	43.75	12790	1.10	48900	4 5 .		
21.0	47.26	13816	1.10	49600	5 0 .		
26.0	38.46	11187	1.44	44400	F 1 2 2 1 4 0 . _ M _ _ _ _ 3 0 . C - -	739	225M
23.0	43.75	12725	1.11	48900	4 5 .		
21.0	47.26	13746	1.11	49600	5 0 .		

NOTE
Other output speeds are available using 2 and 8 pole motors - Please contact our Application Engineers

SERIES F

SELECTION TABLES

GEARED MOTORS

37 kW

4 POLE

N2 R/MIN	i	M2 Nm	Fm	N	Unit Designation	Kg	Motor Sizes
Output Speed	Ratio	Output Torque	Service Factor	Overhung Load	Column Entry [1] Through [20] Spaces to be filled when entering order	Weight of base mount unit	
290	5.08	1182	1.66	29179	F 0 9 2 1 5 . 0 _ M _ _ _ _ 3 7 . A - -	403	225S
225	6.57	1523	1.49	29900	6 . 3		
211	7.00	1627	1.44	29846	7 . 1		
188	7.85	1825	1.36	29739	8 . 0		
167	8.81	2051	1.29	29524	9 . 0		
146	10.13	2355	1.21	29829	1 0 .		
130	11.35	2646	1.13	29829	1 1 .		
116	12.68	2958	1.06	29829	1 2 .		
101	14.66	3406	1.00	29747	1 4 .		
90	16.37	3808	0.93	29803	1 6 .		
84	17.58	4090	0.88	29707	1 8 .		
74	20.04	4681	0.81	29700	2 0 .		
287	5.11	1190	2.15	43500	F 1 0 2 1 5 . 0 _ M _ _ _ _ 3 7 . A - -	491	225S
228	6.43	1492	2.02	43500	6 . 3		
205	7.13	1662	1.92	43500	7 . 1		
188	7.76	1807	1.85	43500	8 . 0		
166	8.81	2052	1.73	43500	9 . 0		
149	9.77	2270	1.66	43500	1 0 .		
127	11.48	2671	1.51	43500	1 1 .		
118	12.39	2889	1.44	43500	1 2 .		
101	14.46	3362	1.35	43500	1 4 .		
94	15.61	3629	1.29	43400	1 6 .		
81	18.07	4212	1.17	43400	1 8 .		
71	20.46	4766	1.09	43400	2 0 .		
64	22.76	5291	1.03	43400	2 2 .		
56	25.77	5988	0.96	43300	2 5 .		
95	15.56	3728	2.22	23700	F 1 1 2 1 1 6 . _ M _ _ _ _ 3 7 . K - -	550	200M
82	17.96	4302	2.11	24600	1 8 .		
72	20.46	4901	1.84	26100	2 0 .		
66	22.42	5371	1.81	26600	2 2 .		
58	25.54	6118	1.56	28300	2 5 .		
52	28.40	6803	1.49	29100	2 8 .		
46	32.34	7747	1.32	30700	3 2 .		
42	34.96	8375	1.21	32100	3 6 .		
37	39.83	9542	1.12	33300	4 0 .		
95	15.56	3715	2.22	23700	F 1 1 2 1 1 6 . _ M _ _ _ _ 3 7 . A - -	574	225S
82	17.96	4288	2.11	24600	1 8 .		
72	20.46	4885	1.84	26100	2 0 .		
66	22.42	5353	1.81	26600	2 2 .		
58	25.54	6098	1.56	28300	2 5 .		
52	28.40	6761	1.49	29100	2 8 .		
46	32.34	7721	1.32	30700	3 2 .		
42	34.96	8347	1.21	32100	3 6 .		
37	39.83	9509	1.12	33300	4 0 .		
51	28.92	6928	2.19	28100	F 1 2 2 1 2 8 . _ M _ _ _ _ 3 7 . K - -	705	200M
47	31.23	7481	2.12	28300	3 2 .		
41	35.61	8531	1.81	35200	3 6 .		
38	38.46	9213	1.73	36300	4 0 .		
34	43.75	10481	1.30	40900	4 5 .		
31	47.26	11322	1.30	41300	5 0 .		
27	53.75	12876	0.87	47400	5 6 .		
25	58.06	13909	0.87	48100	6 3 .		
51	28.92	6905	2.20	28100	F 1 2 2 1 2 8 . _ M _ _ _ _ 3 7 . A - -	729	225S
47	31.23	7456	2.13	28300	3 2 .		
42	35.61	8502	1.82	35200	3 6 .		
38	38.46	9182	1.74	36300	4 0 .		
34	43.75	10445	1.31	40900	4 5 .		
31	47.26	11283	1.31	41300	5 0 .		
27	53.75	12833	0.88	47400	5 6 .		
25	58.06	13862	0.88	48100	6 3 .		
33	44.96	10771	1.48	39100	F 1 2 3 1 4 5 . _ M _ _ _ _ 3 7 . K - -	711	200M
30	48.56	11633	1.38	40500	5 0 .		
25	58.27	13959	1.16	43800	5 6 .		
23	62.94	15078	1.07	45600	6 3 .		
20	72.17	17289	0.94	48200	7 1 .		
19	77.95	18674	0.87	50200	8 0 .		
33	44.96	10734	1.48	39100	F 1 2 3 1 4 5 . _ M _ _ _ _ 3 7 . A - -	724	225S
30	48.56	11594	1.38	40500	5 0 .		
25	58.27	13912	1.16	43800	5 6 .		
24	62.94	15027	1.07	45600	6 3 .		
21	72.17	17321	0.94	48200	7 1 .		
19	77.95	18611	0.87	50200	8 0 .		

NOTE
Other output speeds are available using 2 and 8 pole motors - Please contact our Application Engineers

SERIES F

SELECTION TABLES

GEARED MOTORS

37 kW

6 POLE

45 kW

4 POLE

45 kW

N2 R/MIN	i	M2 Nm	Fm	N	Unit Designation	Kg	
Output Speed	Ratio	Output Torque	Service Factor	Overhung Load	Column Entry [1] Through [20] Spaces to be filled when entering order	Weight of base mount unit	Motor Sizes
26	38.46	13797	1.17	44400	F 1 2 2 1 4 0 . _ M _ _ _ _ 3 7 . M - -	766	225M
23	43.75	15694	0.90	48900	4 5 .		
21	47.26	16954	0.90	49600	5 0 .		
26	38.46	13797	1.17	44400	F 1 2 2 1 4 0 . _ M _ _ _ _ 3 7 . C - -	810	250M
23	43.75	15694	0.90	48900	4 5 .		
21	47.26	16954	0.90	49600	5 0 .		
290	5.08	1437	1.36	28917	F 0 9 2 1 5 . 0 _ M _ _ _ _ 4 5 . A - -	424	225M
225	6.57	1852	1.23	29900	6 . 3		
211	7.00	1979	1.18	29826	7 . 1		
188	7.85	2220	1.12	29680	8 . 0		
167	8.81	2495	1.06	29387	9 . 0		
146	10.13	2865	0.99	29808	1 0 .		
130	11.35	3218	0.93	29808	1 1 .		
116	12.68	3598	0.87	29808	1 2 .		
101	14.66	4142	0.82	29700	1 4 .		
287	5.11	1448	1.77	43500	F 1 0 2 1 5 . 0 _ M _ _ _ _ 4 5 . A - -	509	225M
228	6.43	1815	1.66	43500	6 . 3		
205	7.13	2022	1.58	43500	7 . 1		
188	7.76	2198	1.52	43500	8 . 0		
166	8.81	2495	1.43	43500	9 . 0		
149	9.77	2761	1.37	43500	1 0 .		
127	11.48	3249	1.24	43500	1 1 .		
118	12.39	3513	1.19	43500	1 2 .		
101	14.46	4089	1.11	43500	1 4 .		
94	15.61	4414	1.06	43400	1 6 .		
81	18.07	5122	0.96	43400	1 8 .		
71	20.46	5796	0.89	43400	2 0 .		
64	22.76	6435	0.85	43400	2 2 .		
148	9.97	2895	2.50	20300	F 1 1 2 1 1 0 . _ M _ _ _ _ 4 5 . A - -	589	225M
131	11.33	3290	2.37	21000	1 1 .		
115	12.90	3746	2.08	22200	1 2 .		
108	13.66	3966	2.09	22400	1 4 .		
95	15.56	4518	1.83	23700	1 6 .		
82	17.96	5215	1.74	24600	1 8 .		
72	20.46	5941	1.51	26100	2 0 .		
66	22.42	6510	1.49	26600	2 2 .		
58	25.54	7416	1.28	28300	2 5 .		
52	28.40	8237	1.23	29100	2 8 .		
46	32.34	9391	1.09	30700	3 2 .		
42	34.96	10151	1.00	32100	3 6 .		
37	39.83	11566	0.92	33300	4 0 .		
65	22.84	6632	2.20	22400	F 1 2 2 1 2 2 . _ M _ _ _ _ 4 5 . A - -	744	225M
60	24.67	7163	2.20	19600	2 5 .		
51	28.92	8398	1.81	28100	2 8 .		
47	31.23	9068	1.75	28300	3 2 .		
42	35.61	10340	1.50	35200	3 6 .		
38	38.46	11168	1.43	36300	4 0 .		
34	43.75	12704	1.07	40900	4 5 .		
31	47.26	13723	1.07	41300	5 0 .		
33	44.96	13055	1.22	39100	F 1 2 3 1 4 5 . _ M _ _ _ _ 4 5 . A - -	744	225M
30	48.56	14100	1.14	40500	5 0 .		
25	58.27	16920	0.96	43800	5 6 .		
24	62.94	18276	0.88	45600	6 3 .		
26	38.46	16780	0.96	44400	F 1 2 2 1 4 0 . _ M _ _ _ _ 4 5 . M - -	850	250M
26	38.46	16695	0.96	44400	F 1 2 2 1 4 0 . _ M _ _ _ _ 4 5 . C - -	970	280S

NOTE
Other output speeds are available using 2 and 8 pole motors - Please contact our Application Engineers

SERIES F

SELECTION TABLES

GEARED MOTORS

55 kW

4 POLE

N2 R/MIN	i	M2 Nm	Fm	N	Unit Designation	Kg	Motor Sizes
Output Speed	Ratio	Output Torque	Service Factor	Overhung Load	Column Entry [1] Through [20] Spaces to be filled when entering order	Weight of base mount unit	
327	4.53	1608	2.36	17900	F 1 1 2 1 4 . 5 _ M _ _ _ _ 5 5 . K - -	624	225M
287	5.16	1831	2.36	18100	5 . 0		
268	5.53	1963	2.37	18400	5 . 6		
235	6.30	2236	2.37	18600	6 . 3		
206	7.20	2550	2.36	18900	7 . 1		
180	8.20	2910	2.35	18900	8 . 0		
169	8.75	3105	2.30	19300	9 . 0		
148	9.97	3538	2.04	20300	1 0 .		
131	11.33	4021	1.94	21000	1 1 .		
115	12.90	4578	1.71	22200	1 2 .		
108	13.66	4848	1.71	22400	1 4 .		
95	15.56	5522	1.50	23700	1 6 .		
82	17.96	6374	1.42	24600	1 8 .		
72	20.46	7261	1.23	26100	2 0 .		
66	22.42	7957	1.22	26600	2 2 .		
58	25.54	9064	1.05	28300	2 5 .		
52	28.40	10079	1.00	29100	2 8 .		
46	32.34	11477	0.89	30700	3 2 .		
42	34.96	12407	0.82	32100	3 6 .		
327	4.53	1608	2.36	17900	F 1 1 2 1 4 . 5 _ M _ _ _ _ 5 5 . A - -	650	250M
287	5.16	1831	2.36	18100	5 . 0		
268	5.53	1963	2.37	18400	5 . 6		
235	6.30	2236	2.37	18600	6 . 3		
206	7.20	2550	2.36	18900	7 . 1		
180	8.20	2910	2.35	18900	8 . 0		
169	8.75	3105	2.30	19300	9 . 0		
148	9.97	3538	2.04	20300	1 0 .		
131	11.33	4021	1.94	21000	1 1 .		
115	12.90	4578	1.71	22200	1 2 .		
108	13.66	4848	1.71	22400	1 4 .		
95	15.56	5522	1.50	23700	1 6 .		
82	17.96	6374	1.42	24600	1 8 .		
72	20.46	7261	1.23	26100	2 0 .		
66	22.42	7957	1.22	26600	2 2 .		
58	25.54	9064	1.05	28300	2 5 .		
52	28.40	10079	1.00	29100	2 8 .		
46	32.34	11477	0.89	30700	3 2 .		
42	34.96	12407	0.82	32100	3 6 .		
320	4.63	1643	2.50	21800	F 1 2 2 1 4 . 5 _ M _ _ _ _ 5 5 . K - -	805	225M
296	5.00	1774	2.50	22200	5 . 0		
187	7.90	2804	2.50	23900	8 . 0		
161	9.19	3262	2.50	24200	9 . 0		
128	11.55	4099	2.50	24600	1 1 .		
119	12.48	4429	2.50	24500	1 2 .		
107	13.88	4926	2.43	21400	1 4 .		
99	14.99	5320	2.43	19000	1 6 .		
83	17.77	6307	2.20	17900	1 8 .		
77	19.19	6811	2.20	15100	2 0 .		
65	22.84	8106	1.80	22400	2 2 .		
60	24.67	8755	1.80	19600	2 5 .		
61	28.92	10264	1.48	28100	2 8 .		
47	31.23	11083	1.43	28300	3 2 .		
42	35.61	12638	1.22	35200	3 6 .		
38	38.46	13649	1.17	36300	4 0 .		
34	43.75	15527	0.88	40900	4 5 .		
31	47.26	16773	0.88	41300	5 0 .		
320	4.63	1643	2.50	21800	F 1 2 2 1 4 . 5 _ M _ _ _ _ 5 5 . A - -	805	250M
296	5.00	1774	2.50	22200	5 . 0		
187	7.90	2804	2.50	23900	8 . 0		
161	9.19	3262	2.50	24200	9 . 0		
128	11.55	4099	2.50	24600	1 1 .		
119	12.48	4429	2.50	24500	1 2 .		
107	13.88	4926	2.43	21400	1 4 .		
99	14.99	5320	2.43	19000	1 6 .		
83	17.77	6307	2.20	17900	1 8 .		
77	19.19	6811	2.20	15100	2 0 .		
65	22.84	8106	1.80	22400	2 2 .		
60	24.67	8755	1.80	19600	2 5 .		
61	28.92	10264	1.48	28100	2 8 .		
47	31.23	11083	1.43	28300	3 2 .		
42	35.61	12638	1.22	35200	3 6 .		
38	38.46	13649	1.17	36300	4 0 .		
34	43.75	15527	0.88	40900	4 5 .		
31	47.26	16773	0.88	41300	5 0 .		
33	44.96	15956	0.99	39100	F 1 2 3 1 4 5 . _ M _ _ _ _ 5 5 . K - -	774	225M
10	48.56	17234	0.93	40500	5 0 .		

NOTE
Other output speeds are available using 2 and 8 pole motors - Please contact our Application Engineers

SERIES F

SELECTION TABLES

GEARED MOTORS

75 kW

4 POLE

N2 R/MIN	i	M2 Nm	Fm	N	Unit Designation	Kg			
Output Speed	Ratio	Output Torque	Service Factor	Overhung Load	Column Entry [1] Through [20] Spaces to be filled when entering order	Weight of base mount unit	Motor Sizes		
327	4.53	2192	1.73	17900	F 1 1 2 1 4 . 5 _ M _ _ _ _ 7 5 . K - -	650	250M		
287	5.16	2497	1.73	18100	5 . 0				
268	5.53	2676	1.73	18400	5 . 6				
235	6.30	3049	1.73	18600	6 . 3				
206	7.20	3484	1.73	18900	7 . 1				
180	8.20	3968	1.73	18900	8 . 0				
169	8.75	4235	1.69	19300	9 . 0				
148	9.97	4825	1.50	20300	1 0 .				
131	11.33	5843	1.42	21000	1 1 .				
115	12.90	6243	1.25	22200	1 2 .				
108	13.66	6611	1.25	22400	1 4 .				
95	15.56	7530	1.10	23700	1 6 .				
82	17.96	8692	1.04	24600	1 8 .				
72	20.46	9902	0.91	26100	2 0 .				
66	22.42	10850	0.89	26600	2 2 .				
320	4.63	2241	1.84	21800	F 1 2 2 1 4 . 5 _ M _ _ _ _ 7 5 . K - -			865	250M
296	5.00	2420	1.84	22200	5 . 0				
258	5.73	2773	1.84	22700	5 . 6				
239	6.19	2996	1.84	23100	6 . 3				
202	7.31	3538	1.84	23600	7 . 1				
187	7.90	3823	1.84	23900	8 . 0				
161	9.19	4448	1.84	24200	9 . 0				
149	9.92	4801	1.84	24500	1 0 .				
128	11.55	5590	1.84	24600	1 1 .				
119	12.48	6040	1.84	24500	1 2 .				
107	13.88	6717	1.79	21400	1 4 .				
99	14.99	7254	1.79	19000	1 6 .				
83	17.77	8600	1.62	17900	1 8 .				
77	19.19	9287	1.61	15100	2 0 .				
65	22.84	11053	1.33	22400	2 2 .				
60	24.67	11939	1.32	19600	2 5 .				
51	28.92	13996	1.09	28100	2 8 .				
47	31.23	15114	1.05	28300	3 2 .				
42	35.61	17234	0.90	35200	3 6 .				
38	38.46	18613	0.86	36300	4 0 .				
320	4.63	2236	1.84	21800	F 1 2 2 1 4 . 5 _ M _ _ _ _ 7 5 . A - -	975	280S		
297	5.00	2415	1.84	22200	5 . 0				
259	5.73	2767	1.84	22700	5 . 6				
240	6.19	2990	1.84	23100	6 . 3				
203	7.31	3531	1.84	23600	7 . 1				
188	7.90	3815	1.84	23900	8 . 0				
161	9.19	4439	1.84	24200	9 . 0				
149	9.92	4791	1.84	24500	1 0 .				
128	11.55	5578	1.84	24600	1 1 .				
119	12.48	6028	1.84	24500	1 2 .				
107	13.88	6704	1.79	21400	1 4 .				
99	14.99	7240	1.79	19000	1 6 .				
83	17.77	8582	1.62	17900	1 8 .				
77	19.19	9268	1.61	15100	2 0 .				
65	22.84	11031	1.33	22400	2 2 .				
60	24.67	11915	1.32	19600	2 5 .				
51	28.92	13968	1.09	28100	2 8 .				
47	31.23	15083	1.05	28300	3 2 .				
42	35.61	17199	0.90	35200	3 6 .				
39	38.46	18575	0.86	36300	4 0 .				

90 kW

4 POLE

321	4.63	2682	1.53	21800	F 1 2 2 1 4 . 5 _ M _ _ _ _ 9 0 . A - -	1020	280M
297	5.00	2896	1.53	22200	5 . 0		
259	5.73	3319	1.53	22700	5 . 6		
240	6.19	3585	1.53	23100	6 . 3		
203	7.31	4234	1.53	23600	7 . 1		
188	7.90	4576	1.53	23900	8 . 0		
161	9.19	5323	1.53	24200	9 . 0		
150	9.92	5745	1.53	24500	1 0 .		
128	11.55	6690	1.53	24600	1 1 .		
119	12.48	7228	1.53	24500	1 2 .		
107	13.88	8039	1.49	21400	1 4 .		
99	14.99	8682	1.49	19000	1 6 .		
84	17.77	10292	1.35	17900	1 8 .		
77	19.19	11114	1.35	15100	2 0 .		
65	22.84	13228	1.11	22400	2 2 .		
60	24.67	14288	1.10	19600	2 5 .		
51	28.92	16750	0.91	28100	2 8 .		
48	31.23	18088	0.88	28300	3 2 .		

NOTE

Other output speeds are available using 2 and 8 pole motors - Please contact our Application Engineers

SERIES F

SELECTION TABLES

GEARED MOTORS

110 kW

4 POLE

N2 R/MIN	i	M2 Nm	Fm	N	Unit Designation	Kg	Motor Sizes
Output Speed	Ratio	Output Torque	Service Factor	Overhung Load	Column Entry 1 Through 20 Spaces to be filled when entering order	Weight of base mount unit	
320	4.63	2682	1.25	21800	F 1 2 2 1 4 . 5 _ M _ _ _ _ 1 1 0 K - -	1080	280M
297	5.00	2896	1.25	22200	5 . 0		
259	5.73	3319	1.25	22700	5 . 6		
240	6.19	3585	1.25	23100	6 . 3		
203	7.31	4234	1.25	23600	7 . 1		
188	7.90	4576	1.25	23900	8 . 0		
161	9.19	5323	1.25	24200	9 . 0		
149	9.92	5745	1.25	24500	1 0 .		
128	11.55	6690	1.25	24600	1 1 .		
119	12.48	7228	1.25	24500	1 2 .		
107	13.88	8039	1.22	21400	1 4 .		
99	14.99	8682	1.22	19000	1 6 .		
83	17.77	10292	1.10	17900	1 8 .		
77	19.19	11114	1.10	15100	2 0 .		
65	22.84	13228	0.90	22400	2 2 .		
60	24.67	14288	0.90	19600	2 5 .		

NOTE
Other output speeds are available using 2 and 8 pole motors - Please contact our Application Engineers

SERIES F

DIMENSIONS

MOTORISED

F11 & F12

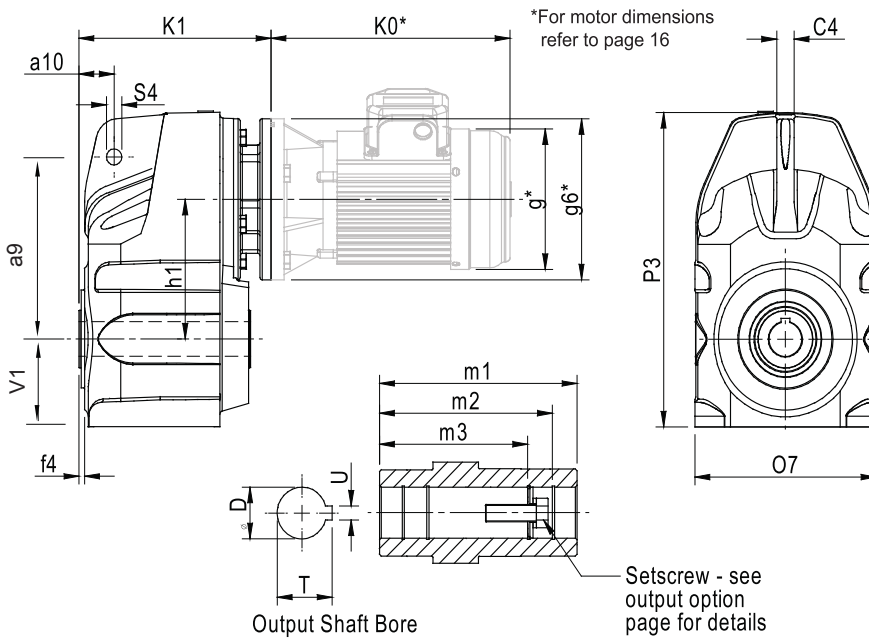

Please Note: The appearance of the F11 & F12 units is different to the other units. See pictures above.

UNIT SIZE	a9	a10	C4	f4	h1	O7	P3	S4	V1	Hollow Output Bore					
										D	m1	m2	m3	T	U
F0222 & F0232	140	25	15	5	96	150	224	15	59	25	117.5	105	89	28.5	8
F0322 & F0332	158	32	16	5	121	171	273	15	76	30	156.5	122	105	33.5	8
F0422 & F0432	170	32	16	5	121	171	273	15	76	35	156.5	132	122	38.5	10
F0522 & F0532	198	41	16	5	144	206	318	15	80	40	179	174	142	43.5	12
F0622 & F0632	218	41	16	6	165	231	365	15	101	40	205	174	156	43.5	12
F0722 & F0732	278	50	20	7	200	282	442	24	127	50	233.5	198	183	54	14
F0822 & F0832	346	62	26	3	243	346	536	24	156	60	270	230	210	64.6	18
F0921 & F0931	395	70	30	5	274	400	612	27	175	70	330	270	-	75	20
F1021 & F1031	485	88	36	5.5	332	470	748	27	216	80	370	313	-	85.5	22
F1121 & F1131	485	89	40	3	385	498	784	26	237	90	350	-	-	95.4	25
F1221 & F1231	550	99	50	4	414	550	877	33	236	100	410	-	-	106.4	28

MOTOR FRAME SIZE	F0222	F0232	F0322	F0332	F0422	F0432	F0522	F0532	F0622	F0632	F0722	F0732	F0822	F0832	F0921	F0931	F1021	F1031	F1121	F1131	F1221	F1231	
	K1	K1	K1	K1	K1	K1	K1	K1	K1	K1	K1	K1	K1	K1	K1	K1	K1	K1	K1	K1	K1	K1	K1
63	154	169	175	188	189	219	200	230	-	250	-	-	-	-	-	-	-	-	-	-	-	-	-
71	158	173	179	192	195	223	206	234	-	256	-	-	-	-	-	-	-	-	-	-	-	-	-
80	171	186	192	205	213	236	224	247	259	274	340	325	354	380	-	441	-	-	-	-	-	-	-
90	181	196	202	215	223	246	234	257	269	284	340	335	354	380	-	441	-	-	-	-	-	-	-
100	189	204	210	223	250	254	261	265	281	311	346	347	360	386	390	447	-	446	-	-	-	-	-
112	189	204	210	223	250	254	261	265	281	311	346	347	360	386	390	447	-	446	-	446	-	-	-
132	-	-	-	-	250	-	261	-	303	311	346	369	360	-	390	447	-	446	-	446	-	524	-
160	-	-	-	-	-	-	-	-	311	-	376	-	395	-	425	482	-	476	-	476	-	496	-
180	-	-	-	-	-	-	-	-	-	-	-	-	395	-	425	482	491	476	516	496	516	496	-
200	-	-	-	-	-	-	-	-	-	-	-	-	395	-	425	482	491	-	516	524	516	524	-
225	-	-	-	-	-	-	-	-	-	-	-	-	422	-	452	509	521	-	546	526	546	526	-
250	-	-	-	-	-	-	-	-	-	-	-	-	-	-	-	-	521	-	546	-	546	-	-
280	-	-	-	-	-	-	-	-	-	-	-	-	-	-	-	-	-	-	546	-	546	-	-

SERIES F

DIMENSIONS

MOTORISED QUAD

*For motor dimensions refer to page 16

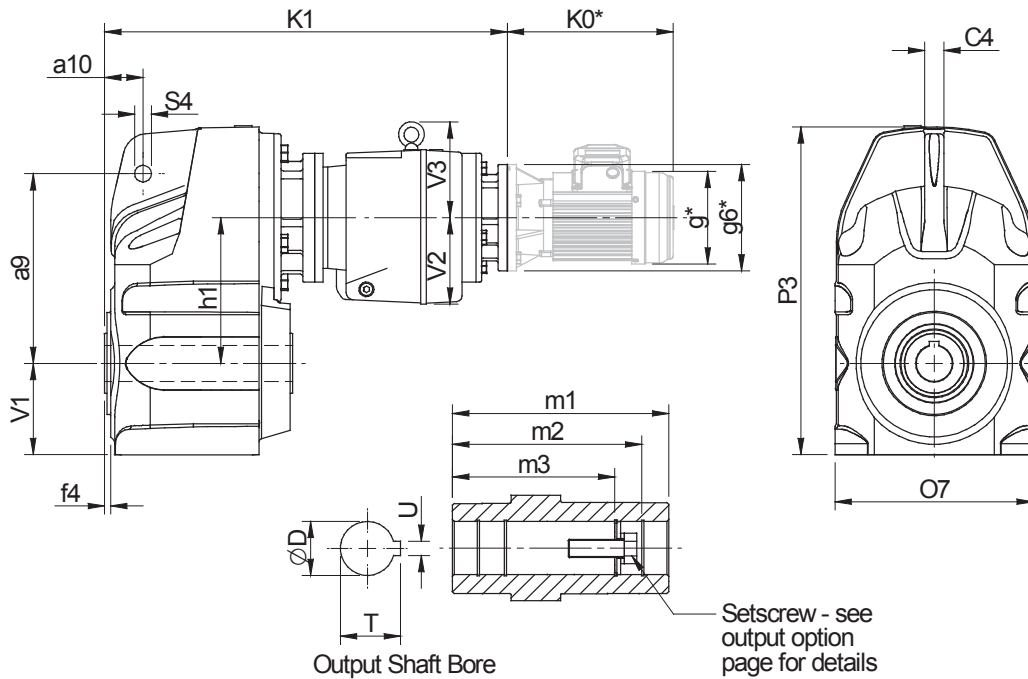

UNIT SIZE	a9	a10	C4	f4	h1	O7	P3	S4	V1	V2	V3	Hollow Output Bore					
												D	m1	m2	m3	T	U
F0342	158	32	16	5	121	171	273	15	76	76	74	30	156.5	122	105	33.5	8
F0442	170	32	16	5	121	171	273	15	76	76	74	35	156.5	132	122	38.5	10
F0542	198	41	16	5	144	206	318	15	80	91	90	40	179	174	142	43.5	12
F0642	218	41	16	6	165	231	365	15	101	91	90	40	205	174	156	43.5	12
F0742	278	50	20	7	200	282	442	24	127	91	90	50	233.5	198	183	54	14
F0842	346	62	26	3	243	346	536	24	156	115	93	60	270	230	210	64.6	18
F0941	395	70	30	5	274	400	612	27	175	115	93	70	330	270	-	75	20
F1041	485	88	36	5.5	332	470	748	27	216	140	155	80	370	313	-	95.4	25

MOTOR FRAME SIZE	F0342	F0442	F0542	F0642	F0742	F0842	F0941	F1041
	K1	K1	K1	K1	K1	K1	K1	K1
63	361	361	413	424	459	515	564	-
71	365	365	417	428	463	521	570	-
80	378	378	430	441	476	539	588	672
90	388	388	440	451	486	549	598	682
100	396	396	448	448	494	576	625	694
112	396	396	448	448	494	576	625	694
132	-	-	-	-	-	576	625	716
160	-	-	-	-	-	-	-	724
180	-	-	-	-	-	-	-	-
200	-	-	-	-	-	-	-	-
225	-	-	-	-	-	-	-	-

SERIES F

MOTORISED BACKSTOP MODULE

Motorised backstop modules can be fitted between the gear unit and motor. The backstop device incorporates high quality centrifugal lift off sprags which are wear free above the lift off speed (n min). To ensure correct operation motor speed must exceed lift off speed.

Suitable for ambient temperature -40°C to $+50^{\circ}\text{C}$

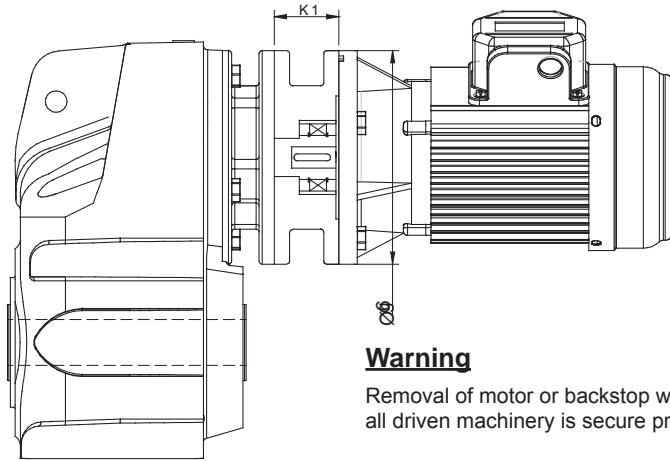

Warning

Removal of motor or backstop will release the drive. Ensure all driven machinery is secure prior to any maintenance work

IEC B5 FLANGE

Motor Frame Size	Lift off Speed ('n' min) (rev/min)	Rated Locking Torque ('T max') (at motor) (Nm)	øg6	K1
100	670	170	250	70
112	670	170	250	70
132	620	940	300	95
160	620	940	350	130
180	620	940	350	130
200	550	1260	400	130

NEMA C FLANGE

Motor Frame Size	Lift off Speed ('n' min) (rev/min)	Rated Locking Torque ('T max') (at motor) (Nm)	øg6	K1
182TC / 184TC	670	300	228	95.25
213TC / 215TC	670	300	228	95.25
254TC / 256TC	620	940	228	120.65
284TC / 286TC	620	940	280	136.5
324TC / 326TC	550	1260	330	152.4

When a backstop module is fitted dimension K1 should be added to the overall length of the geared motor assembly.

Rotation of outputshaft must be specified when ordering as viewed from the outputshaft end (as shown in the diagram) see page 18 for column 20 entry

CW	-	Free Rotation	-	Clockwise
		Locked	-	Anticlockwise
AC	-	Free Rotation	-	Anticlockwise
		Locked	-	Clockwise

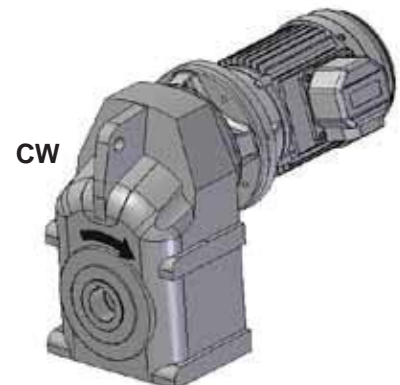

SERIES F

DIMENSIONS

MOTORISED OPTIONS

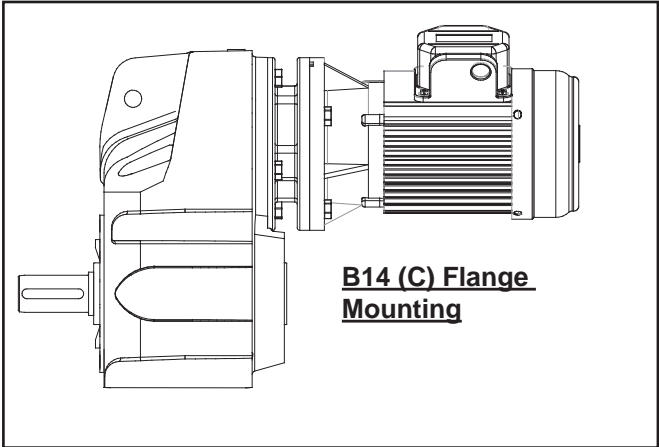
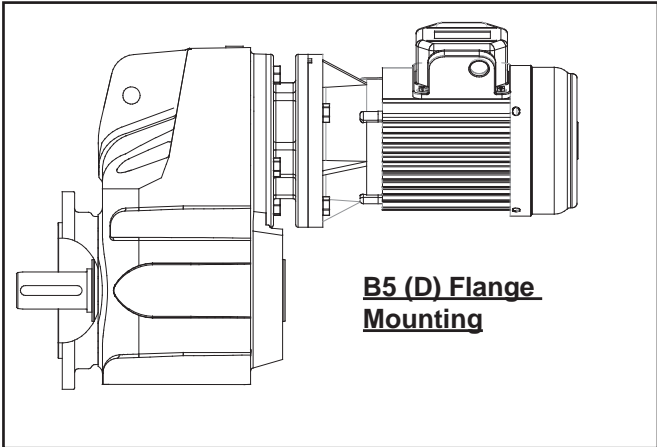
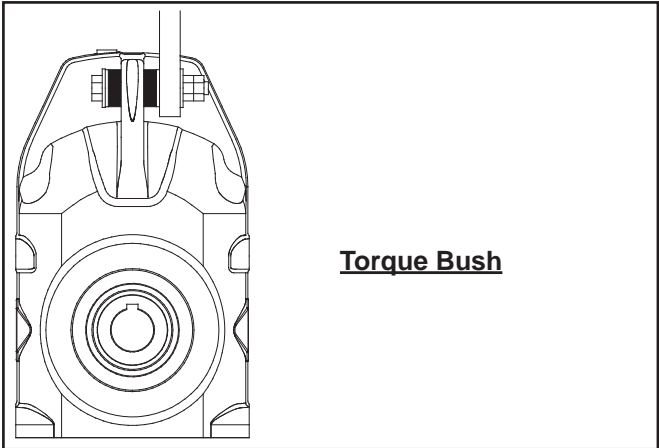
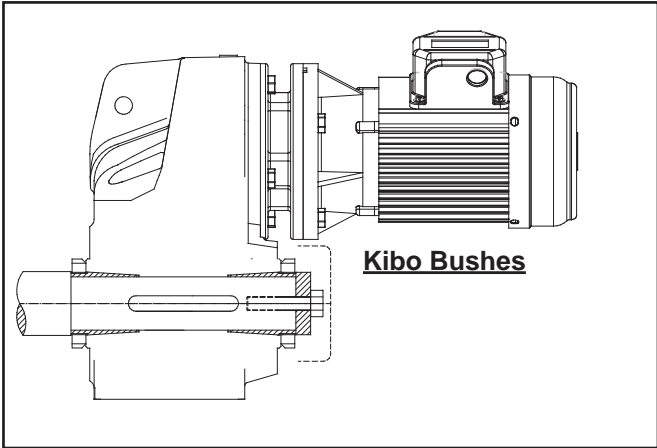

SERIES F

NOTES

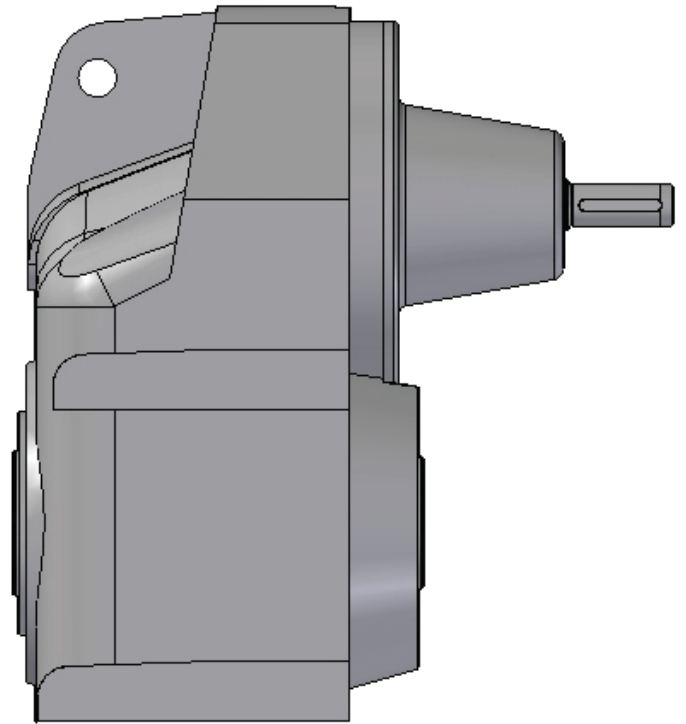

REDUCER
SERIES F

SERIES F

OVERHUNG & AXIAL LOADS (NEWTONS) ON SHAFTS

Maximum permissible overhung loads

When a sprocket, gear etc. is mounted on the shaft a calculation, as below, must be made to determine the overhung load on the shaft, and the results compared to the maximum permissible overhung loads tabulated. Overhung loads can be reduced by increasing the diameter of the sprocket, gear, etc. If the maximum permissible overhung load is exceeded, the sprocket, gear, etc. should be mounted on a separate shaft, flexibly coupled and supported in its own bearings, or the gear unit shaft should be extended to run in an outboard bearing. Alternatively, a larger gear is often a less expensive solution.

Permissible overhung loads vary according to the direction of rotation. The values tabulated are for the most unfavourable direction with the unit transmitting full rated power and the load P applied midway along the shaft extension. Hence they can sometimes be increased for a more favourable direction of rotation, or if the power transmitted is less than the rated capacity of the gear unit, or if the load is applied nearer to the gear unit case. Refer to Application Engineering for further details. In any event, the sprocket, gear etc. should be positioned as close as possible to the gear unit case in order to reduce bearing loads and shaft stresses, and to prolong life.

All units will accept 100% momentary overload on stated capacities.

Overhung load (Newtons)

$$P = \frac{kW \times 9,500,000 \times K}{N \times R}$$

Where

- P = equivalent overhung load (Newtons)
 kW = power transmitted by the shaft (kilowatts)
 N = speed of shaft (rev/min)
 R = pitch radius of sprocket, etc. (mm)
 K = factor

Note: 1 Newton = 0.101972 kp = 0.227809 lbf.

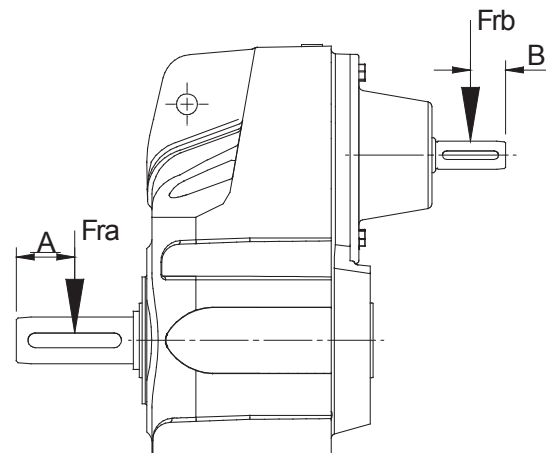

Inputshaft Overhung Loads, Frb (Kn) 1450 rpm

Two, Three and Five Stage Units

	F02	F03	F04	F05	F06	F07	F08	F09	F10	F11	F12
2 Stage	1.5	1.5	1.5	1.25	1.05	2.1	3.1	3.5	4.5	N/A	N/A
3 Stage	1.5	1.5	1.5	1.5	1.5	1.25	2.1	3.1	3.5	N/A	N/A
4 Stage	1.5	1.5	1.5	1.5	1.5	1.5	1.5	1.5	1.8	N/A	N/A

For output overhung load Fra consult ratings tables.

Axial Thrust Capacities (Newtons)

No check or calculation is required for axial loads (F_A) towards or away from the unit up to 50% of the permissible overhung load. If the axial thrust considerably exceeds these values or if there is a combination of axial thrust loads and overhung loads please contact Application Engineering.

Overhung member K (factor)

Chain sprocket*	1.00
Spur or helical pinion	1.25
Vee belt sheave	1.50
Flat belt pulley	2.00

* If multistrand chain drives are equally loaded and the outer strand is further than dimension A output or B input, refer to Application Engineering.

Distance midway along the shaft extension

Size of unit	NO of Reductions	Dimension A (mm)	Dimension B (mm)
F02	2	-	20
	3	-	20
	4	-	-
F03	2	23.5	20
	3	23.5	20
	4	-	20
F04	2	28	20
	3	28	20
	4	28	20
F05	2	33	20
	3	33	20
	4	32	20
F06	2	38	20
	3	38	20
	4	38	20
F07	2	47.5	25
	3	47.5	20
	4	47.5	20
F08	2	55	30
	3	55	25
	4	55	20
F09	2	68	40
	3	65	30
	4	65	20
F10	2	85	35
	3	85	40
	4	85	25
F11	2	70	-
	3	70	-
	4	-	-
F12	2	80	-
	3	80	-
	4	-	-

SERIES F

THERMAL POWER RATINGS

Thermal Ratings kW

Thermal ratings are a measure of the units ability to dissipate heat, if they are exceeded the lubricant may break down resulting in premature gear failure.

Thermal rating are based on an ambient temperature of 20°C, where units are to operate in other ambient temperatures thermal ratings must be adjusted by the following factors

Thermal Power (kW)

Ambient Temperature Deg C							
-20	-10	0	10	20	30	40	50
1.57	1.43	1.29	1.14	1	0.86	0.71	0.5

i Ratio	N1 (rpm)	F0222	F0322 F0422	F0522	F0622	F0722	F0822	F0921	F1021	F1121	F1221
Up to 16	2900	-	-	-	-	-	-	-	-	-	-
	1750	5.8	8.7	16	20	30	47	66	98	113	173
	1450	5.1	8.1	14	18	27	42	59	88	103	158
	960	4.6	6.0	10	14	20	32	44	66	77	119
20	2900	7.1	8.5	15	20	28	48	62	87	101	154
	1750	5.2	7.6	14	18	25	43	55	77	91	140
	1450	4.6	6.8	12	15	23	39	50	70	82	127
	960	4.2	5.0	9.2	12	17	29	37	52	61	95
22	2900	4.5	7.5	14	17	26	41	55	78	95	140
	1750	4.7	6.8	12	15	23	36	49	70	84	124
	1450	4.1	6.1	11	14	21	32	45	63	75	112
	960	3.7	4.5	8	10	16	25	33	47	57	85
25	2900	3.1	7.1	14	16	24	38	50	72	87	129
	1750	4.4	6.2	12	13	21	33	44	63	77	116
	1450	3.9	5.6	11	12	19	29	40	57	69	104
	960	3.4	4.1	8.0	9.0	14	22	30	42	51	76
28	2900	2.7	6.5	12	15	22	34	48	69	80	116
	1750	4.1	5.6	10	12	19	29	42	61	69	102
	1450	3.5	5.0	9.3	11	17	26	37	53	62	91
	960	3.1	3.8	6.9	8.2	13	20	28	40	47	67
32	2900	2.5	6.2	11	14	21	32	45	63	73	112
	1750	3.8	5.3	9.9	12	18	27	38	55	64	95
	1450	3.3	4.7	8.9	11	16	24	34	49	57	85
	960	2.9	3.4	6.6	7.9	12	18	25	36	42	64
36	2900	2.7	5.5	10	13	19	30	41	60	71	104
	1750	3.5	4.7	8.6	11	16	26	35	51	61	88
	1450	2.9	4.2	7.6	9.5	14	23	31	45	53	77
	960	2.6	3.1	5.7	6.9	11	17	23	33	40	57
40	2900	2.5	5.3	9.2	12	18	26	38	56	66	98
	1750	3.1	4.4	7.5	10	15	22	32	46	55	82
	1450	2.5	3.9	6.6	8.9	13	19	28	42	49	73
	960	2.3	2.9	4.9	6.5	9.6	14	21	30	36	54
50	2900	1.9	4.8	8.7	10	17	23	34	49	57	87
	1750	2.8	3.9	7.1	8.6	13	19	28	39	47	71
	1450	2.3	3.4	6.2	7.6	12	17	25	35	41	63
	960	2.0	2.5	4.6	5.6	8.6	12	18	26	30	46

Note: When checking thermal capacities use actual load required to be transmitted, not rating of prime mover.

SERIES F

DOUBLE REDUCTION RATINGS

Note: Input Power, Pm may exceed thermal limit,
Check thermal power

Pm - Input Power (kW)
M2 - Output Torque (Nm)
i - Exact Ratio (:1)
N2 - Output Speed (rpm)
fra - Overhung Load (kN)

Column Entry			Input Speed N1 (rpm)	F0222					F0322					F0422					F0522						
				N2 (rpm)	i (i)	M2 (Nm)	Pm (kW)	fra (kN)	N2 (rpm)	i (i)	M2 (Nm)	Pm (kW)	fra (kN)	N2 (rpm)	i (i)	M2 (Nm)	Pm (kW)	fra (kN)	N2 (rpm)	i (i)	M2 (Nm)	Pm (kW)	fra (kN)		
6	7	8	(rpm)	(rpm)	(i)	(Nm)	(kW)	(kN)	(rpm)	(i)	(Nm)	(kW)	(kN)	(rpm)	(i)	(Nm)	(kW)	(kN)	(rpm)	(i)	(Nm)	(kW)	(kN)		
5	.	0	2900																599	4.841	355	23.10	0.42		
			1450																299		394	12.80	0.73		
			960																		198	395	8.44	1.00	
			725																		149	395	6.38	1.25	
6	.	3	2900	491	5.903	52	2.80	1.07											426	6.806	428	19.70	0.55		
			1450	245		61	1.62	1.38													213	516	11.80	0.95	
			960	162		68	1.19	1.60														141	516	7.84	1.31
			725	122		72	0.95	1.78														106	516	5.92	1.64
7	.	1	2900	363	7.974	61	2.41	1.19	463	6.262	251	12.60	0.99	463	6.262	251	12.60	0.99	380	7.628	453	18.60	0.60		
			1450	181		71	1.40	1.54	231		286	7.16	1.44	231		286	7.16	1.44	190		542	11.10	1.04		
			960	120		79	1.03	1.79	153		286	4.74	1.80	153		286	4.74	1.80	125		556	7.54	1.44		
			725	90		84	0.82	1.98	115		287	3.58	2.11	115		287	3.58	2.11	95		557	5.69	1.78		
9	.	0	2900	319	9.069	65	2.25	1.25	330	8.784	283	10.10	1.19	330	8.784	283	10.10	1.19	338	8.563	477	17.50	0.66		
			1450	159		76	1.32	1.61	165		314	5.60	1.73	165		314	5.60	1.73	169		557	10.20	1.13		
			960	105		84	0.96	1.87	109		319	3.76	2.17	109		319	3.76	2.17	112		558	6.74	1.57		
			725	79		89	0.77	2.08	82		319	2.84	2.53	82		319	2.84	2.53	84		558	5.09	1.96		
1	0	.	2900	282	10.27	68	2.09	1.31	299	9.680	287	9.31	1.26	299	9.680	287	9.31	1.26	266	10.87	527	15.20	0.80		
			1450	141		81	1.23	1.68	149		319	5.16	1.83	149		319	5.16	1.83	133		580	8.34	1.37		
			960	93		88	0.89	1.96	99		327	3.50	2.28	99		327	3.50	2.28	88		614	5.84	1.89		
			725	70		94	0.71	2.17	74		327	2.64	2.67	74		327	2.64	2.67	66		615	4.42	2.37		
1	2	.	2900	220	13.14	75	1.81	1.43	263	10.99	292	8.34	1.35	263	10.99	292	8.34	1.35	235	12.33	537	13.70	0.88		
			1450	110		89	1.06	1.84	131		326	4.65	1.96	131		326	4.65	1.96	117		591	7.49	1.51		
			960	73		97	0.77	2.14	87		329	3.10	2.45	87		329	3.10	2.45	77		625	5.24	2.10		
			725	55		104	0.62	2.37	65		329	2.34	2.87	65		329	2.34	2.87	58		630	3.99	2.62		
1	4	.	2900	204	14.16	76	1.72	1.47	207	13.96	304	6.83	1.53	207	13.96	304	6.83	1.53	197	14.70	550	11.70	1.01		
			1450	102		92	1.01	1.89	103		337	3.78	2.23	103		337	3.78	2.23	98		605	6.44	1.74		
			960	67		100	0.73	2.21	68		337	2.50	2.80	68		337	2.50	2.80	65		641	4.51	2.40		
			725	51		108	0.60	2.44	51		337	1.89	3.27	51		337	1.89	3.27	49		648	3.44	2.99		
1	6	.	2900	162	17.88	85	1.50	1.60	182	15.86	309	6.12	1.64	182	15.86	309	6.12	1.64	171	16.93	561	10.40	1.12		
			1450	81		99	0.87	2.06	91		345	3.41	2.39	91		345	3.41	2.39	85		575	5.31	1.94		
			960	53		110	0.64	2.41	60		354	2.31	2.99	60		354	2.31	2.99	56		575	3.52	2.69		
			725	40		120	.53]	2.67	45		354	1.74	3.49	45		354	1.74	3.49	42		576	2.66	3.38		
2	0	.	2900	143	20.27	89	1.38	1.68	148	19.46	319	5.15	1.84	148	19.46	319	5.15	1.84	147	19.69	572	9.12	1.27		
			1450	71		103	0.80	2.16	74		357	2.87	2.67	74		357	2.87	2.67	73		629	5.00	2.19		
			960	47		116	0.59	2.51	49		380	2.02	3.34	49		380	2.02	3.34	48		650	3.42	3.04		
			725	35		127	0.49	2.80	37		386	1.55	3.88	37		386	1.55	3.88	36		650	2.58	3.81		
2	2	.	2900	125	23.16	93	1.27	1.76	134	21.59	326	4.74	1.94	134	21.59	326	4.74	1.94	131	22.03	582	8.29	1.39		
			1450	62		108	0.73	2.27	67		362	2.63	2.82	67		362	2.63	2.82	65		639	4.55	2.40		
			960	41		123	0.55	2.64	44		380	1.83	3.54	44		380	1.83	3.54	43		677	3.19	3.31		
			725	31		129	0.44	2.93	33		380	1.38	4.13	33		380	1.38	4.13	32		684	2.43	4.18		
2	5	.	2900	112	25.77	96	1.18	1.83	118	24.53	332	4.25	2.08	118	24.53	332	4.25	2.08	123	23.48	587	7.85	1.46		
			1450	56		112	0.68	2.36	59		370	2.36	3.02	59		370	2.36	3.02	61		645	4.30	2.52		
			960	37		129	0.52	2.74	39		386	1.63	3.78	39		386	1.63	3.78	40		683	3.02	3.51		
			725	28		129	0.39	3.04	29		386	1.23	4.43	29		386	1.23	4.43	30		701	2.34	4.39		

SERIES F

DOUBLE REDUCTION RATINGS

Note: Input Power, Pm may exceed thermal limit,
Check thermal power

Pm - Input Power (kW)
M2 - Output Torque (Nm)
i - Exact Ratio (:1)
N2 - Output Speed (rpm)
fra - Overhung Load (kN)

Column Entry			Input Speed N1 (rpm)	F0222					F0322					F0422					F0522				
				N2 (rpm)	i (i)	M2 (Nm)	Pm (kW)	fra (kN)	N2 (rpm)	i (i)	M2 (Nm)	Pm (kW)	fra (kN)	N2 (rpm)	i (i)	M2 (Nm)	Pm (kW)	fra (kN)	N2 (rpm)	i (i)	M2 (Nm)	Pm (kW)	fra (kN)
6	7	8	2900	102	28.41	99	1.10	1.89	104	27.86	338	3.82	2.22	104	27.86	338	3.82	2.22	104	27.83	601	6.78	1.66
2	8	.	1450	51		117	0.65	2.44	52		375	2.11	3.23	52		375	2.11	3.23	52		660	3.72	2.86
			960	33		129	0.47	2.86	34		375	1.40	4.07	34		375	1.40	4.07	34		696	2.59	3.98
			725	25		129	0.36	3.17	26		375	1.06	4.70	26		375	1.06	4.70	26		696	1.96	4.91
			2900	92	31.26	102	1.03	1.97	94	30.68	343	3.52	2.35	94	30.68	343	3.52	2.35	97	29.71	605	6.40	1.75
3	2	.	1450	46		121	0.61	2.53	47		374	1.91	3.41	47		374	1.91	3.41	48		667	3.52	3.04
			960	30		129	0.43	2.96	31		374	1.27	4.27	31		374	1.27	4.27	32		699	2.44	4.18
			725	23		129	0.32	3.26	23		375	0.96	5.02	23		375	0.96	5.02	24		699	1.84	5.23
			2900	79	36.63	107	0.92	2.08	82	35.30	351	3.13	2.53	82	35.30	351	3.13	2.53	78	36.87	623	5.32	2.08
3	6	.	1450	39		129	0.56	2.69	41		391	1.74	3.68	41		391	1.74	3.68	39		687	2.92	3.58
			960	26		129	0.37	3.12	27		393	1.16	4.60	27		393	1.16	4.60	26		709	2.00	4.91
			725	19		51	0.28	3.50	20		393	0.87	5.42	20		393	0.87	5.42	19		709	1.51	6.28
			2900	65	43.94	112	0.81	2.23	75	38.37	355	2.91	2.65	75	38.37	355	2.91	2.65	66	43.47	638	4.62	2.37
4	0	.	1450	32		129	0.46	2.89	37		371	1.52	3.88	37		371	1.52	3.88	33		703	2.54	4.08
			960	21		129	0.31	3.37	25		371	1.01	4.80	25		371	1.01	4.80	22		716	1.71	5.60
			725	16		129	0.23	3.73	18		371	0.76	5.73	18		371	0.76	5.73	16		716	1.29	7.19
			2900	56	51.22	117	0.72	2.36	62	46.07	366	2.50	2.94	62	46.07	366	2.50	2.94	60	47.60	646	4.28	2.55
5	0	.	1450	28		129	0.40	3.04	31		391	1.34	4.27	31		391	1.34	4.27	30		712	2.35	4.39
			960	18		129	0.26	3.57	20		392	0.89	5.42	20		392	0.89	5.42	20		720	1.57	6.03
			725	14		129	0.20	3.91	15		392	0.67	6.33	15		392	0.67	6.33	15		720	1.19	7.56
			2900	50	56.91	122	0.68	2.46	52	55.28	371	2.12	3.23	52	55.28	371	2.12	3.23	49	58.34	522	2.83	2.99
5	6	.	1450	25		129	0.36	3.17	26		387	1.10	4.70	26		387	1.10	4.70	24		543	1.47	5.23
			960	16		129	0.24	3.73	17		387	0.73	5.91	17		387	0.73	5.91	16		566	1.01	7.19
			725	12		129	0.18	4.14	13		387	0.55	6.83	13		387	0.55	6.83	12		582	0.79	9.00
			2900	42	68.54	129	0.59	2.62	46	62.29	339	1.72	3.45	46	62.29	339	1.72	3.45	44	65.02	462	2.25	3.25
6	3	.	1450	21		129	0.30	3.37	23		363	0.92	5.02	23		363	0.92	5.02	22		480	1.17	5.60
			960	14		129	0.20	3.86	15		378	0.63	6.33	15		378	0.63	6.33	14		501	0.80	7.98
			725	10		129	0.15	3.86	11		389	0.49	7.10	11		389	0.49	7.10	11		512	0.62	9.20
			2900	36	78.56	113	0.46	2.77	40	72.41	293	1.28	3.72	40	72.41	293	1.28	3.72	39	72.92	364	1.58	3.58
7	1	.	1450	18		113	0.22	3.57	20		314	0.69	5.42	20		314	0.69	5.42	19		364	0.79	6.28
			960	12		113	0.15	3.86	13		328	0.47	6.83	13		328	0.47	6.83	13		364	0.52	8.46
			725	9		113	0.11	3.86	10		337	0.37	7.10	10		337	0.37	7.10	9		364	0.40	9.20
			2900	32	89.28	105	0.37	2.89	35	82.18	264	1.02	4.00	35	82.18	264	1.02	4.00					
9	0	.	1450	16		112	0.20	3.73	17		283	0.54	5.91	17		283	0.54	5.91					
			960	10		112	0.13	3.86	11		295	0.38	7.10	11		295	0.38	7.10					
			725	8		112	0.10	3.86	8		303	0.29	7.10	8		303	0.29	7.10					
			2900		93.43				31	93.43	235	0.80	4.27	31	93.43	235	0.80	4.27					
1	0	0	1450						15		252	0.43	6.33	15		252	0.43	6.33					
			960						10		263	0.30	7.10	10		263	0.30	7.10					
			725						7		270	0.23	7.10	7		270	0.23	7.10					

SERIES F

DOUBLE REDUCTION RATINGS

Note: Input Power, Pm may exceed thermal limit,
Check thermal power

Pm - Input Power (kW)
M2 - Output Torque (Nm)
i - Exact Ratio (:1)
N2 - Output Speed (rpm)
fra - Overhung Load (kN)

Column Entry			Input Speed N1 (rpm)	F0622					F0722					F0822					
				N2 (rpm)	i (i)	M2 (Nm)	Pm (kW)	fra (kN)	N2 (rpm)	i (i)	M2 (Nm)	Pm (kW)	fra (kN)	N2 (rpm)	i (i)	M2 (Nm)	Pm (kW)	fra (kN)	
6	7	8																	
			2900																
5	.	0	1450																
			960																
			725																
			2900																
6	.	3	1450																
			960																
			725																
			2900	465		380	19.20	1.85	428			560	26.10	2.05	416		908	41.30	2.12
7	.	1	1450	232	6.224	468	11.80	2.63	214	6.772	564	13.10	2.89	208	6.959	914	20.70	3.02	
			960	154		509	8.44	3.22	141		565	8.65	3.54	137		917	13.70	3.74	
			725	116		509	6.38	3.71	107		566	6.53	4.05	104		918	10.30	4.31	
			2900	331		465	16.70	2.20	309		771	25.90	2.41	293		1290	41.30	2.54	
9	.	0	1450	165	8.750	573	10.20	3.11	154	9.380	783	13.10	3.39	146	9.865	1300	20.70	3.62	
			960	109		649	7.66	3.83	102		784	8.65	4.15	97		1300	13.70	4.46	
			725	82		665	5.92	4.42	77		785	6.53	4.76	73		1300	10.30	5.16	
			2900	295		495	15.80	2.33	275		822	24.50	2.55	264		1440	41.30	2.68	
1	0	.	1450	147	9.807	610	9.72	3.30	137	10.54	880	13.10	3.59	132	10.96	1450	20.70	3.81	
			960	97		691	7.27	4.06	91		881	8.65	4.39	87		1450	13.70	4.72	
			725	73		717	5.69	4.68	68		882	6.53	5.06	66		1450	10.30	5.43	
			2900	263		526	15.00	2.47	250		866	23.50	2.67	237		1550	39.80	2.83	
1	2	.	1450	131	11.01	649	9.20	3.49	125	11.59	968	13.10	3.75	118	12.19	1610	20.70	4.04	
			960	87		718	6.74	4.29	82		969	8.65	4.62	78		1610	13.70	4.99	
			725	65		719	5.09	4.96	62		970	6.53	5.29	59		1610	10.30	5.75	
			2900	207		593	13.30	2.78	191		986	20.40	3.05	183		1750	34.90	3.23	
1	4	.	1450	103	13.98	730	8.15	3.94	95	15.13	1210	12.50	4.30	91	15.76	2080	20.70	4.61	
			960	68		808	5.96	4.85	63		1270	8.65	5.25	60		2090	13.70	5.70	
			725	51		808	4.50	5.60	47		1270	6.53	6.06	45		2090	10.30	6.60	
			2900	182		629	12.40	2.96	168		1050	19.10	3.25	163		1850	32.70	3.42	
1	6	.	1450	91	15.85	775	7.63	4.19	84	17.21	1290	11.70	4.56	81	17.70	2270	20.10	4.89	
			960	60		825	5.37	5.16	55		1440	8.65	5.61	54		2340	13.70	6.02	
			725	45		825	4.06	5.96	42		1440	6.53	6.41	40		2340	10.30	7.01	
			2900	153		681	11.30	3.23	138		1140	17.20	3.58	133		2020	29.20	3.80	
2	0	.	1450	76	18.90	838	6.92	4.59	69	20.89	1410	10.50	5.02	66	21.70	2490	17.90	5.43	
			960	50		842	4.60	5.66	45		1520	7.54	6.19	44		2810	13.40	6.68	
			725	38		842	3.47	6.49	34		1520	5.69	7.11	33		2870	10.30	7.73	
			2900	133		723	10.40	3.47	126		1190	16.20	3.74	118		2120	27.20	4.04	
2	2	.	1450	66	21.76	741	5.31	4.92	63	22.98	1470	9.98	5.25	59	24.45	2610	16.70	5.75	
			960	44		741	3.52	6.03	41		1590	7.14	6.48	39		2950	12.50	7.10	
			725	33		741	2.66	6.96	31		1590	5.39	7.44	29		3170	10.10	8.26	
			2900	114		770	9.52	3.75	109		1260	14.90	4.02	101		2260	24.90	4.37	
2	5	.	1450	57	25.31	837	5.16	5.30	54	26.41	1550	9.18	5.66	50	28.46	2780	15.30	6.26	
			960	37		837	3.42	6.58	36		1720	6.73	6.91	33		3150	11.40	7.73	
			725	28		837	2.58	7.56	27		1720	5.08	7.96	25		3320	9.11	8.91	

SERIES F

DOUBLE REDUCTION RATINGS

Note: Input Power, Pm may exceed thermal limit,
Check thermal power

Pm - Input Power (kW)
M2 - Output Torque (Nm)
i - Exact Ratio (:1)
N2 - Output Speed (rpm)
fra - Overhung Load (kN)

Column Entry			Input Speed N1 (rpm)	F0622					F0722					F0822				
				N2 (rpm)	i (i)	M2 (Nm)	Pm (kW)	fra (kN)	N2 (rpm)	i (i)	M2 (Nm)	Pm (kW)	fra (kN)	N2 (rpm)	i (i)	M2 (Nm)	Pm (kW)	fra (kN)
6	7	8	2900	102		798	8.83	3.96	96		1320	13.80	4.27	91		2320	23.10	4.61
2	8	.	1450	51	28.32	880	4.86	5.60	48	29.95	1620	8.47	6.00	45	31.57	2690	13.40	6.60
			960	33		880	3.22	6.96	32		1830	6.35	7.32	30		2700	8.85	8.12
			725	25		880	2.43	8.00	24		1860	4.86	8.43	22		2700	6.68	9.51
			2900	96		828	8.59	4.08	87		1380	13.10	4.48	83		2370	21.50	4.83
3	2	.	1450	48	30.18	891	4.61	5.77	43	33.03	1690	8.03	6.33	41	34.55	2580	11.70	6.92
			960	31		892	3.06	7.18	29		1750	5.48	7.68	27		2580	7.74	8.57
			725	24		892	2.31	8.16	21		1750	4.14	9.00	20		2580	5.85	9.98
			2900	81		882	7.72	4.44	76		1450	12.00	4.79	74		2450	19.70	5.12
3	6	.	1450	40	35.77	887	3.88	6.32	38	37.83	1790	7.40	6.73	37	39.09	2770	11.10	7.29
			960	26		887	2.57	7.84	25		1800	4.93	8.26	24		2770	7.34	9.10
			725	20		887	1.94	8.94	19		1800	3.72	9.45	18		2770	5.54	10.53
			2900	75		889	7.30	4.62	67		1520	11.10	5.10	65		2510	17.80	5.47
4	0	.	1450	37	38.19	890	3.65	6.58	33	42.77	1780	6.51	7.21	32	44.13	2910	10.30	7.85
			960	25		890	2.41	8.00	22		1780	4.31	8.80	21		2910	6.84	9.74
			725	18		890	1.82	9.43	16		1780	3.25	10.28	16		2910	5.16	11.19
			2900	61		890	5.89	5.12	58		1570	9.92	5.47	54		2560	15.00	6.02
5	0	.	1450	30	47.40	892	2.95	7.30	29	49.59	1790	5.66	7.68	27	53.49	3160	9.26	8.57
			960	20		893	1.95	8.94	19		1790	3.74	9.45	17		3160	6.13	10.84
			725	15		893	1.47	10.33	14		1790	2.83	10.98	13		3160	4.63	12.44
			2900	51		891	5.01	5.60	49		1620	8.62	5.94	46		2620	13.20	6.53
5	6	.	1450	25	55.89	892	2.50	8.00	24	59.14	1840	4.88	8.43	23	62.38	3300	8.31	9.30
			960	17		893	1.66	9.70	16		1840	3.23	10.28	15		3380	5.63	11.56
			725	12		893	1.25	11.30	12		1840	2.44	11.84	11		3380	4.25	13.54
			2900	47		858	4.41	5.83	44		1640	7.97	6.26	42		2670	12.30	6.84
6	3	.	1450	23	61.20	892	2.29	8.34	22	64.77	1840	4.48	8.80	21	68.52	3370	7.73	9.74
			960	15		893	1.52	10.33	14		1840	2.96	10.98	14		3390	5.14	11.97
			725	11		893	1.15	11.30	11		1840	2.24	12.35	10		3390	3.88	14.22
			2900	38		673	2.83	6.49	37		1490	6.05	6.82	34		2740	10.20	7.62
7	1	.	1450	19	75.00	699	1.47	9.18	18	77.72	1590	3.23	9.70	17	83.97	3390	6.34	10.84
			960	12		729	1.01	11.30	12		1650	2.21	11.84	11		3390	4.20	13.54
			725	9		750	0.79	11.30	9		1650	1.67	13.63	8		3390	3.17	15.93
			2900	34		595	2.25	6.86	32		1220	4.30	7.32	31		2760	9.47	7.98
9	0	.	1450	17	83.59	619	1.17	9.70	16	89.42	1270	2.23	10.28	15	91.70	3300	5.65	11.56
			960	11		645	0.80	11.30	10		1290	1.51	12.94	10		3300	3.74	14.22
			725	8		659	0.62	11.30	8		1290	1.14	14.44	7		3300	2.82	17.05
			2900	30		468	1.58	7.30	29		1070	3.41	7.68	27		2700	8.06	8.57
1	0	0	1450	15	93.75	469	0.79	10.33	14	99.36	1100	1.75	10.98	13	105.6	2690	4.03	12.44
			960	10		469	0.52	11.30	9		1100	1.16	13.63	9		2920	2.89	15.00
			725	7		469	0.40	11.30	7		1100	0.87	15.42	6		2940	2.19	18.45

SERIES F

DOUBLE REDUCTION RATINGS

Note: Input Power, Pm may exceed thermal limit,
Check thermal power

Pm - Input Power (kW)
M2 - Output Torque (Nm)
i - Exact Ratio (:1)
N2 - Output Speed (rpm)
fra - Overhung Load (kN)

Column Entry			Input Speed N1 (rpm)	F0921					F1021					F1121					F1221				
				N2 (rpm)	i (i)	M2 (Nm)	Pm (kW)	fra (kN)	N2 (rpm)	i (i)	M2 (Nm)	Pm (kW)	fra (kN)	N2 (rpm)	i (i)	M2 (Nm)	Pm (kW)	fra (kN)	N2 (rpm)	i (i)	M2 (Nm)	Pm (kW)	fra (kN)
6	7	8	(rpm)	(i)	(Nm)	(kW)	(kN)	(rpm)	(i)	(Nm)	(kW)	(kN)	(rpm)	(i)	(Nm)	(kW)	(kN)	(rpm)	(i)	(Nm)	(kW)	(kN)	
4	.	5	2900	-	-	-	-	-	-	-	-	-	-	640	4.530	-	-	-	626	4.630	-	-	-
			1450	-	-	-	-	-	-	-	-	-	-	320		3798	125.5	17.9	313		4115	133.1	21.8
			960	-	-	-	-	-	-	-	-	-	-	212		3798	81.65	21.3	207		4115	86.55	25.8
			725	-	-	-	-	-	-	-	-	-	-	160		3798	61.45	23.9	157		4115	65.15	28.8
5	.	0	2900	570	-	-	-	568	5.107	-	-	-	-	562	5.160	-	-	-	580	5.000	-	-	-
			1450	285	1960	60.30	32.00	284		2560	78.20	43.00	281	4326		125.5	18.10	290	4445		133.1	22.2	
			960	189	2220	45.20	32.00	188		2560	51.80	43.00	186	4326		81.65	21.80	192	4445		86.55	26.3	
			725	143	2420	37.10	32.00	142		2560	39.10	43.00	141	4326		61.45	24.50	145	4445		65.15	29.4	
5	.	6	2900	-	-	-	-	-	-	-	-	-	-	524	5.530	-	-	-	506	5.730	-	-	-
			1450	-	-	-	-	-	-	-	-	-	-	262		4642	125.5	18.40	253		5097	133.1	22.70
			960	-	-	-	-	-	-	-	-	-	-	174		4642	81.65	22.10	168		5097	86.55	27.00
			725	-	-	-	-	-	-	-	-	-	-	131		4642	61.45	24.90	127		5097	65.15	30.30
6	.	3	2900	442	-	-	-	451	6.433	-	-	-	-	460	6.300	-	-	-	468	6.190	-	-	-
			1450	221	2270	54.20	32.00	225		3020	73.60	43.00	230	5288		125.5	18.60	234	5505		133.1	23.10	
			960	146	2570	40.50	32.00	149		3220	51.80	43.00	152	5288		81.65	22.40	155	5505		86.55	27.50	
			725	110	2800	33.20	32.00	113		3220	39.10	43.00	115	5288		61.45	25.30	117	5505		65.15	30.80	
7	.	1	2900	414	-	-	-	407	7.133	-	-	-	-	403	7.200	-	-	-	397	7.310	-	-	-
			1450	207	2340	52.30	32.00	203		3200	70.00	43.00	201	6037		125.5	18.90	198	6500		133.1	23.60	
			960	137	2650	39.10	32.00	135		3580	51.80	43.00	133	6037		81.65	22.90	131	6500		86.55	28.30	
			725	104	2890	32.10	32.00	102		3580	39.10	43.00	101	6037		61.45	25.90	99	6500		65.15	31.80	
8	.	0	2900	362	-	-	-	370	7.846	-	-	-	-	354	8.200	-	-	-	367	7.900	-	-	-
			1450	181	2490	49.50	32.00	185		3340	67.20	43.00	177	6852		125.5	18.90	184	7021		133.1	23.90	
			960	120	2820	37.00	32.00	122		3780	50.30	43.00	117	6852		81.65	23.10	122	7021		86.55	28.70	
			725	90	3070	30.40	32.00	92		3900	39.10	43.00	88	6852		61.45	26.30	92	7021		65.15	32.30	
9	.	0	2900	329	-	-	-	329	8.810	-	-	-	-	331	8.750	-	-	-	316	9.190	-	-	-
			1450	165	2640	46.80	32.00	165		3560	63.10	43.00	166	7141		122.2	19.30	158	8166		133.1	24.20	
			960	109	2990	35.00	32.00	109		4040	47.20	43.00	110	7192		80.04	23.60	104	8166		86.55	29.30	
			725	82	3250	28.80	32.00	82		4390	38.80	43.00	83	7192		60.25	26.80	79	8166		65.15	33.10	
1	0	.	2900	286	-	-	-	297	9.772	-	-	-	-	291	9.970	-	-	-	292	9.920	-	-	-
			1450	143	2850	44.00	32.00	148		3770	60.40	43.00	145	7224		108.5	20.30	146	8820		133.1	24.50	
			960	95	3220	32.90	32.00	98		4270	45.20	43.00	96	8193		80.03	23.60	97	8820		86.55	29.70	
			725	72	3510	27.00	32.00	74		4550	37.10	43.00	73	8193		60.23	27.00	73	8820		65.15	33.60	
1	1	.	2900	256	-	-	-	253	11.48	-	-	-	-	256	11.33	6328	167.3	16.50	251	11.55	-	-	-
			1450	128	2990	41.10	32.00	126		4040	55.00	43.00	128	7791		103.0	21.00	126	10268		133.1	24.60	
			960	85	3380	30.80	32.00	84		4580	41.10	43.00	85	8370		71.94	25.00	83	10268		86.55	30.10	
			725	64	3680	25.30	32.00	63		4980	33.80	43.00	64	8370		54.15	28.50	63	10268		65.15	34.20	
1	2	.	2900	229	-	-	-	234	12.39	-	-	-	-	225	12.90	6340	147.2	17.50	232	12.48	-	-	-
			1450	114	3140	38.60	32.00	117		4170	52.50	43.00	112	7806		90.61	22.20	116	11090		133.1	24.50	
			960	76	3550	28.90	32.00	77		4720	39.30	43.00	74	8881		67.04	25.80	77	11090		86.55	30.40	
			725	57	3850	23.60	32.00	59		5140	32.30	43.00	56	9434		54.17	28.70	58	11090		65.15	34.60	
1	4	.	2900	198	-	-	-	201	14.46	-	-	-	-	212	13.66	6733	147.6	17.60	209	13.88	9398	202.8	17.70
			1450	99	3390	36.20	32.00	100		4530	49.00	43.00	106	8289		90.86	22.40	104	11993		129.4	21.40	
			960	65	3840	27.10	32.00	66		5130	36.70	43.00	70	8744		62.34	26.90	69	11993		84.14	30.90	
			725	49	4180	22.20	32.00	50		5580	30.10	43.00	53	8744		46.92	30.60	52	11993		63.33	35.20	

SERIES F

DOUBLE REDUCTION RATINGS

Note: Input Power, Pm may exceed thermal limit,
Check thermal power

Pm - Input Power (kW)
M2 - Output Torque (Nm)
i - Exact Ratio (:1)
N2 - Output Speed (rpm)
fra - Overhung Load (kN)

Column Entry			Input Speed N1 (rpm)	F0921					F1021					F1121					F1221							
				N2 (rpm)	i (i)	M2 (Nm)	Pm (kW)	fra (kN)	N2 (rpm)	i (i)	M2 (Nm)	Pm (kW)	fra (kN)	N2 (rpm)	i (i)	M2 (Nm)	Pm (kW)	fra (kN)	N2 (rpm)	i (i)	M2 (Nm)	Pm (kW)	fra (kN)			
6	7	8																								
			2900	177		-	-	-	186			-	-	-	186			6708	129.1	18.60	193			10138	202.5	15.90
1	6	.	1450	89	16.37	3550	33.90	32.00	93	15.61	4670	46.80	43.00	93	15.56	8258	79.47	23.70	97	14.99			12954	129.4	19.00	
			960	59		4020	25.40	32.00	61		5290	35.00	43.00	62		9396	58.80	27.60	64				12954	84.16	31.10	
			725	44		4310	20.50	32.00	46		5750	28.80	43.00	47		9960	46.92	30.80	48				12954	63.34	35.60	
			2900	165		-	-	-	160			-	-	-	163			7357	122.68	19.3	163			10577	178.3	17.00
1	8	.	1450	82	17.58	3610	32.00	32.00	80	18.07	4910	42.40	43.00	82	17.76	9058	75.52	24.6	82	17.77			13884	116.99	17.90	
			960	55		4090	24.00	32.00	53		5560	31.70	43.00	54		10120	54.87	28.8	54				15151	83.03	26.10	
			725	41		4310	19.10	32.00	40		6050	26.10	43.00	41		10120	41.3	32.8	41				15254	62.92	35.90	
			2900	145		-	-	-	142			-	-	-	142			7282	106.59	20.50	151			11409	178.1	14.90
2	0	.	1450	72	20.04	3760	29.20	32.00	71	20.46	5150	39.30	43.00	71	20.46	8965	65.61	26.10	76	19.19			14966	116.78	15.10	
			960	48		4240	21.80	32.00	47		5830	29.40	43.00	47		10200	48.55	30.30	50				15852	80.44	26.10	
			725	36		4240	16.50	32.00	35		6340	24.10	43.00	35		10617	38.04	34.10	38				15957	60.95	36.70	
			2900	128		3300	45.60	32.00	127		4440	61.20	43.00	129		7854	104.91	20.90	127				11145	146.1	20.60	
2	2	.	1450	64	22.70	4070	28.00	32.00	64	22.76	5470	37.60	43.00	65	22.42	9669	64.58	26.60	63	22.84			14520	95.85	22.40	
			960	42		4310	19.60	32.00	42		6190	28.10	43.00	43		10120	43.96	31.90	42				16005	68.24	31.30	
			725	32		4310	14.80	32.00	32		6740	23.10	43.00	32		10120	33.09	36.30	32				16100	51.67	39.50	
			2900	112		3480	42.10	32.00	113		4650	56.60	43.00	114		7732	90.66	22.20	118				12019	145.9	18.50	
2	5	.	1450	56	25.88	4280	25.80	32.00	56	25.77	5730	34.80	43.00	57	25.54	9519	55.81	28.30	59	24.67			15757	95.64	19.60	
			960	37		4310	17.20	32.00	37		6480	26.00	43.00	38		10617	40.48	33.10	39				15946	62.95	36.10	
			725	28		4310	13.00	32.00	28		7050	21.40	43.00	28		10617	30.47	37.70	29				16039	47.65	41.20	
			2900	102		3220	35.50	32.00	103		4730	52.80	43.00	102		8433	88.93	22.60	100				11582	119.9	25.30	
2	8	.	1450	51	28.41	4060	22.30	32.00	52	28.04	5820	32.40	43.00	51	28.40	10120	53.36	29.10	50	28.92			15188	78.64	28.10	
			960	34		4240	15.40	32.00	34		6400	23.50	43.00	34		10120	34.7	35.50	33				16086	54.17	38.60	
			725	26		4240	11.60	32.00	26		6400	17.80	43.00	26		10120	26.12	40.30	25				16172	40.99	44.10	
			2900	92		3250	32.30	32.00	92		4910	49.30	43.00	90		8302	76.88	24.10	93				12488	119.8	23.2	
3	2	.	1450	46	31.56	4110	20.30	32.00	46	31.60	6040	30.30	43.00	45	32.34	10221	47.32	30.70	46	31.23			15874	76.11	28.30	
			960	30		4240	13.90	32.00	30		6400	21.20	43.00	30		10617	31.97	36.90	31				16024	49.97	40.30	
			725	23		4240	10.50	32.00	23		6400	15.00	43.00	22		10617	24.06	41.80	23				16108	37.81	45.90	
			2900	79		3960	33.80	32.00	82		5240	46.60	43.00	83		9043	77.46	24.3	81				11943	100.4	28.40	
3	6	.	1450	40	36.69	4310	18.40	32.00	41	35.32	6460	28.60	43.00	41	34.96	10120	43.35	32.10	41	35.61			15465	64.03	35.20	
			960	26		4310	12.20	32.00	27		7250	21.30	43.00	27		10120	28.19	39.00	27				16150	44.17	42.50	
			725	20		4310	9.18	32.00	21		7250	16.00	43.00	21		10120	21.22	44.10	20				16229	33.41	48.40	
			2900	71		4100	31.60	32.00	74		5440	43.50	43.00	73		8893	66.87	25.90	75				12874	100.3	27.90	
4	0	.	1450	36	40.76	4310	16.60	32.00	37	39.25	6690	26.70	43.00	36	39.83	10617	39.91	33.30	38	38.46			15951	62.10	36.30	
			960	24		4310	11.00	32.00	24		7250	19.10	43.00	24		10617	25.96	40.50	25				16087	40.73	44.40	
			725	18		4310	8.27	32.00	18		7250	14.50	43.00	18		10617	19.54	45.80	19				16163	30.80	50.30	
			2900	65		3460	24.30	32.00	65		5570	39.30	43.00	64		8153	54.57	28.40	66				10498	71.86	32.80	
4	5	.	1450	33	44.58	4310	15.10	32.00	33	44.43	6400	22.50	43.00	32	45.04	8545	28.60	37.80	33	43.75			13655	46.74	40.90	
			960	22		4310	10.00	32.00	22		6400	14.90	43.00	21		8710	18.96	45.10	22				14114	31.42	48.90	
			725	16		4310	7.57	32.00	16		6400	11.20	43.00	16		8780	14.38	50.50	17				14233	23.85	55.10	
			2900	59		3500	22.30	32.00	57		5850	35.80	43.00	57		9287	54.58	28.50	61				11310	71.67	33.20	
5	0	.	1450	29	49.22	4240	13.50	32.00	28	51.19	6400	19.50	43.00	28	51.30	9733	28.60	38.40	31	47.26			14749	46.73	41.30	
			960	20		4240	8.92	32.00	19		6400	12.90	43.00	19		9921	18.96	45.90	20				15244	31.41	49.60	
			725	15		4240	6.73	32.00	14		6400	9.77	43.00	14		10000	14.38	51.60	15				15373	23.84	55.90	

SERIES F

DOUBLE REDUCTION RATINGS

Note: Input Power, Pm may exceed thermal limit,
Check thermal power

Pm - Input Power (kW)
M2 - Output Torque (Nm)
i - Exact Ratio (:1)
N2 - Output Speed (rpm)
fra - Overhung Load (kN)

Column Entry			Input Speed N1 (rpm)	F0921					F1021					F1121					F1221					
				N2 (rpm)	i (i)	M2 (Nm)	Pm (kW)	fra (kN)	N2 (rpm)	i (i)	M2 (Nm)	Pm (kW)	fra (kN)	N2 (rpm)	i (i)	M2 (Nm)	Pm (kW)	fra (kN)	N2 (rpm)	i (i)	M2 (Nm)	Pm (kW)	fra (kN)	
6	7	8	2900	50	57.58	4310	23.50	32.00	52	55.97	6160	34.60	43.00	56	51.85	7406	42.78	31.20	54	53.75	10598	58.74	35.90	
5	6	.	1450	25		4310	11.70	32.00	26		7250	20.30	43.00	28		7617	22.00	41.40	27		11213	31.08	47.50	
			960	17		4310	7.77	32.00	17		7250	13.40	43.00	19		7720	14.50	49.10	18		11370	20.49	56.50	
			725	13		4310	5.87	32.00	13		7250	10.10	43.00	14		7779	11.00	54.80	13		11458	15.54	62.20	
			2900	46	63.56	4310	21.30	32.00	45	64.49	6460	31.50	43.00	49	59.06	8435	42.77	31.60	50	58.06	11471	59.86	36.30	
6	3	.	1450	23		4310	10.60	32.00	22		7250	17.60	43.00	25		8677	22.00	42.20	25		12112	31.08	48.20	
			960	15		4310	7.03	32.00	15		7250	11.70	43.00	16		8794	14.50	50.20	17		12281	20.49	57.40	
			725	11		4310	5.31	32.00	11		7250	8.82	43.00	12		8860	11.00	56.00	12		12376	15.54	62.20	
			2900	43	67.71	3610	16.80	32.00	42	69.24	6160	27.90	43.00	-	-	-	-	-	-	-	-	-	-	
7	1	.	1450	21		3950	9.16	32.00	21		6170	14.00	43.00	-		-	-	-	-		-	-	-	-
			960	14		3950	6.06	32.00	14		6170	9.25	43.00	-		-	-	-	-		-	-	-	-
			725	11		3950	4.58	32.00	10		6170	6.98	43.00	-		-	-	-	-		-	-	-	-
			2900	38	76.14	3610	14.90	32.00	39	74.39	5600	23.70	43.00	-	-	-	-	-	-	-	-	-	-	
8	0	.	1450	19		3660	7.56	32.00	19		5610	11.80	43.00	-		-	-	-	-		-	-	-	
			960	13		3660	5.01	32.00	13		5610	7.84	43.00	-		-	-	-	-		-	-	-	
			725	10		3660	3.78	32.00	10		5610	5.92	43.00	-		-	-	-	-		-	-	-	
			2900	33	87.44	4310	15.50	32.00	33	87.21	7080	25.60	43.00	-	-	-	-	-	-	-	-	-	-	
9	0	.	1450	17		4310	7.75	32.00	17		7250	13.10	43.00	-		-	-	-	-		-	-	-	
			960	11		4310	5.13	32.00	11		7250	8.66	43.00	-		-	-	-	-		-	-	-	
			725	8		4310	3.87	32.00	8		7250	6.54	43.00	-		-	-	-	-		-	-	-	
			2900	29	98.32	4310	13.80	32.00	31	93.70	7040	23.70	43.00	-	-	-	-	-	-	-	-	-	-	
1	0	0	1450	15		4310	6.91	32.00	15		7040	11.80	43.00	-		-	-	-	-		-	-	-	
			960	10		4310	4.57	32.00	10		7050	7.84	43.00	-		-	-	-	-		-	-	-	
			725	7		4310	3.45	32.00	8		7050	5.92	43.00	-		-	-	-	-		-	-	-	

SERIES F

DOUBLE REDUCTION RATINGS

Note: Input Power, Pm may exceed thermal limit,
Check thermal power

Pm - Input Power (kW)
M2 - Output Torque (Nm)
i - Exact Ratio (:1)
N2 - Output Speed (rpm)
fra - Overhung Load (kN)

Column Entry			Input Speed N1 (rpm)	F0232					F0332					F0432					F0532				
				N2 (rpm)	i (i)	M2 (Nm)	Pm (kW)	fra (kN)	N2 (rpm)	i (i)	M2 (Nm)	Pm (kW)	fra (kN)	N2 (rpm)	i (i)	M2 (Nm)	Pm (kW)	fra (kN)	N2 (rpm)	i (i)	M2 (Nm)	Pm (kW)	fra (kN)
6	7	8	2900															36	78.8	448	1.82	3.81	
			1450															18		530	1.07	6.55	
			960															12		617	0.82	9.00	
			725														9	685		0.69	9.20		
9	0	.	2900	31	92.02	128	0.45	2.93										33	86.8	433	1.59	4.08	
			1450	15		129	0.23	3.81									16	519		0.95	7.19		
			960	10		135	0.16	3.86									11	605		0.73	9.20		
			725	7		141	0.12	3.86									8	673		0.62	9.20		
1	0	0	2900	28	101.5	129	0.41	3.04	29	99.52	303	0.98	4.43	29	99.52	303	0.98	4.43	29	99.86	447	1.43	4.51
			1450	14		129	0.20	3.86	14		366	0.59	6.57	14		366	0.59	6.57	14		547	0.87	7.98
			960	9		137	0.14	3.86	9		417	0.44	7.10	9		417	0.44	7.10	9		638	0.67	9.20
			725	7		144	0.11	3.86	7		424	0.34	7.10	7		424	0.34	7.10	7		710	0.57	9.20
1	1	2	2900	25	111.6	129	0.37	3.17	26	109.7	309	0.90	4.70	26	109.7	309	0.90	4.70	26	108.6	457	1.35	4.91
			1450	12		130	0.19	3.86	13		380	0.55	6.83	13		380	0.55	6.83	13		566	0.83	8.46
			960	8		139	0.13	3.86	8		423	0.41	7.10	8		423	0.41	7.10	8		660	0.64	9.20
			725	6		146	0.10	3.86	6		425	0.31	7.10	6		425	0.31	7.10	6		735	0.54	9.20
1	2	5	2900	22	130.8	129	0.32	3.32	24	120.7	319	0.85	4.91	24	120.7	319	0.85	4.91	22	130.3	480	1.18	5.60
			1450	11		133	0.16	3.86	12		398	0.53	7.10	12		398	0.53	7.10	11		609	0.74	9.20
			960	7		143	0.12	3.86	7		429	0.38	7.10	7		429	0.38	7.10	7		712	0.58	9.20
			725	5		147	0.09	3.86	6		429	0.28	7.10	6		429	0.28	7.10	5		771	0.47	9.20
1	6	0	2900	18	156.9	129	0.27	3.57	20	141.5	332	0.75	5.42	20	141.5	332	0.75	5.42	18	156.4	502	1.03	6.55
			1450	9		138	0.14	3.86	10		413	0.47	7.10	10		413	0.47	7.10	9		650	0.66	9.20
			960	6		147	0.10	3.86	6		431	0.32	7.10	6		431	0.32	7.10	6		761	0.51	9.20
			725	4		147	0.08	3.86	5		431	0.24	7.10	5		431	0.24	7.10	4		771	0.39	9.20
1	8	0	2900	15	182.9	129	0.23	3.81	17	169.7	348	0.66	5.91	17	169.7	348	0.66	5.91	16	176.2	526	0.96	7.19
			1450	7		141	0.12	3.86	8		425	0.40	7.10	8		425	0.40	7.10	8		682	0.62	9.20
			960	5		147	0.09	3.86	5		433	0.27	7.10	5		433	0.27	7.10	5		771	0.46	9.20
			725	3		147	0.07	3.86	4		433	0.20	7.10	4		433	0.20	7.10	4		771	0.35	9.20
2	0	0	2900	14	203.3	129	0.21	3.86	14	197.8	376	0.61	6.57	14	197.8	376	0.61	6.57	14	204.9	561	0.88	7.98
			1450	7		144	0.11	3.86	7		436	0.35	7.10	7		436	0.35	7.10	7		728	0.57	9.20
			960	4		147	0.08	3.86	4		441	0.24	7.10	4		441	0.24	7.10	4		771	0.40	9.20
			725	3		147	0.06	3.86	3		441	0.18	7.10	3		441	0.18	7.10	3		771	0.30	9.20
2	2	5	2900	11	244.8	132	0.17	3.86	13	219.8	390	0.57	6.83	13	219.8	390	0.57	6.83	12	232.5	591	0.81	9.00
			1450	5		147	0.10	3.86	6		441	0.32	7.10	6		441	0.32	7.10	6		731	0.50	9.20
			960	3		147	0.06	3.86	4		441	0.21	7.10	4		441	0.21	7.10	4		762	0.35	9.20
			725	2		147	0.05	3.86	3		441	0.16	7.10	3		441	0.16	7.10	3		771	0.27	9.20
2	8	0	2900	10	280.6	132	0.16	3.86	10	264.7	408	0.49	7.10	10	264.7	408	0.49	7.10	10	264.3	621	0.75	9.20
			1450	5		147	0.08	3.86	5		442	0.27	7.10	5		442	0.27	7.10	5		651	0.39	9.20
			960	3		147	0.06	3.86	3		442	0.18	7.10	3		442	0.18	7.10	3		679	0.27	9.20
			725	2		147	0.04	3.86	2		442	0.13	7.10	2		442	0.13	7.10	2		699	0.21	9.20
3	1	5	2900	9	318.8	138	0.14	3.86	9	303.4	418	0.44	7.10	9	303.4	418	0.44	7.10					
			1450	4		147	0.07	3.86	4		432	0.23	7.10	4		432	0.23	7.10					
			960	3		147	0.05	3.86	3		432	0.15	7.10	3		432	0.15	7.10					
			725	2		147	0.04	3.86	2		432	0.11	7.10	2		432	0.11	7.10					
3	6	0	2900						8	344.8	401	0.37	7.10	8	344.8	401	0.37	7.10					
			1450					4	425		0.20	7.10	4	425		0.20	7.10						
			960					2	425		0.13	7.10	2	425		0.13	7.10						
			725					2	425		0.10	7.10	2	425		0.10	7.10						

SERIES F

TRIPLE REDUCTION RATINGS

Note: Input Power, Pm may exceed thermal limit,
Check thermal power

Pm - Input Power (kW)
M2 - Output Torque (Nm)
i - Exact Ratio (:1)
N2 - Output Speed (rpm)
fra - Overhung Load (kN)

Column Entry			Input Speed N1 (rpm)	F0632					F0732					F0832				
				N2 (rpm)	i (i)	M2 (Nm)	Pm (kW)	fra (kN)	N2 (rpm)	i (i)	M2 (Nm)	Pm (kW)	fra (kN)	N2 (rpm)	i (i)	M2 (Nm)	Pm (kW)	fra (kN)
6	7	8																
			2900	28		578	1.82	4.62	26		1060	3.11	8.10	25		3100	8.70	8.91
1	0	0	1450	14	101.4	682	1.07	8.36	13	108.6	1240	1.82	11.38	12	114.2	3390	4.72	12.95
			960	9		795	0.82	11.30	8		1430	1.38	14.44	8		3390	3.12	15.93
			725	7		883	0.69	11.30	6		1580	1.16	16.63	6		3390	2.36	18.45
			2900	25		557	1.59	5.09	25		1010	2.80	8.26	23		3000	7.69	9.30
1	1	2	1450	12	111.6	668	0.95	9.53	12	115.7	1190	1.63	11.84	11	124.9	3390	4.31	13.54
			960	8		779	0.73	11.30	8		1380	1.25	14.44	7		3390	2.85	17.05
			725	6		866	0.62	11.30	6		1530	1.05	16.63	5		3390	2.15	19.70
			2900	22		576	1.43	5.68	21		1060	2.47	9.00	20		3120	7.05	9.98
1	2	5	1450	11	128.4	704	0.87	10.27	10	137.1	1270	1.47	12.94	10	141.3	3390	3.81	14.22
			960	7		822	0.67	11.30	7		1470	1.13	15.42	6		3390	2.52	18.45
			725	5		915	0.57	11.30	5		1640	0.95	17.00	5		3390	1.90	19.00
			2900	20		589	1.35	6.16	19		1080	2.35	9.45	18		3220	6.45	10.53
1	6	0	1450	10	139.6	729	0.83	11.15	9	146.4	1300	1.41	13.63	9	159.5	3390	3.38	15.00
			960	6		851	0.64	11.30	6		1510	1.09	16.63	6		3390	2.23	18.45
			725	5		932	0.53	11.30	4		1680	0.91	17.00	4		3440	1.71	19.70
			2900	17		618	1.18	7.08	15		1140	2.00	10.61	14		3380	5.59	11.97
1	8	0	1450	8	167.6	784	0.74	11.30	7	181.7	1420	1.24	15.42	7	193.4	3390	2.79	17.05
			960	5		917	0.58	11.30	5		1650	0.96	17.00	4		3390	1.85	19.00
			725	4		959	0.45	11.30	3		1840	0.80	17.00	3		3540	1.45	19.70
			2900	14		647	1.03	8.36	13		1190	1.77	11.38	12		3390	4.81	12.95
2	0	0	1450	7	201.1	837	0.66	11.30	6	214.2	1510	1.12	16.63	6	225.5	3390	2.40	18.45
			960	4		944	0.50	11.30	4		1770	0.87	17.00	4		3480	1.62	19.70
			725	3		988	0.39	11.30	3		1970	0.73	17.00	3		3600	1.27	19.70
			2900	12		677	0.96	9.53	12		1220	1.66	11.84	11		3390	4.38	13.54
2	2	5	1450	6	226.6	878	0.62	11.30	6	234.6	1570	1.06	17.00	5	247.7	3390	2.18	19.70
			960	4		962	0.45	11.30	4		1830	0.82	17.00	3		3530	1.50	19.70
			725	3		1010	0.35	11.30	3		2040	0.69	17.00	2		3600	1.15	19.70
			2900	11		722	0.88	11.30	10		1310	1.46	12.94	9		3390	3.57	15.00
2	8	0	1450	5	263.4	923	0.56	11.30	5	287.5	1700	0.94	17.00	4	303.6	3420	1.79	19.70
			960	3		985	0.39	11.30	3		1990	0.73	17.00	3		3600	1.25	19.70
			725	2		1010	0.31	11.30	2		2120	0.59	17.00	2		3600	0.94	19.70
			2900	9		761	0.81	11.30	9		1400	1.39	13.63	8		3390	3.27	15.93
3	1	5	1450	4	298.9	941	0.50	11.30	4	320.4	1810	0.90	17.00	4	331.5	3460	1.66	19.70
			960	3		981	0.35	11.30	2		2100	0.69	17.00	2		3600	1.14	19.70
			725	2		1010	0.27	11.30	2		2120	0.53	17.00	2		3600	0.86	19.70
			2900	8		800	0.75	11.30	8		1460	1.30	14.44	7		3390	2.85	17.05
3	6	0	1450	4	339.8	839	0.39	11.30	4	359.4	1780	0.79	17.00	3	381.8	3540	1.48	19.70
			960	2		875	0.27	11.30	2		1780	0.52	17.00	2		3600	1.00	19.70
			725	2		900	0.21	11.30	2		1780	0.40	17.00	1		3600	0.75	19.70

SERIES F

TRIPLE REDUCTION RATINGS

Note: Input Power, Pm may exceed thermal limit, Check thermal power page

Pm - Input Power (kW)
 M2 - Output Torque (Nm)
 i - Exact Ratio (:1)
 N2 - Output Speed (rpm)
 fra - Overhung Load (kN)

Column Entry			Input Speed N1 (rpm)	F0931					F1031					F1131					F1231						
				N2 (rpm)	i (i)	M2 (Nm)	Pm (kW)	fra (kN)	N2 (rpm)	i (i)	M2 (Nm)	Pm (kW)	fra (kN)	N2 (rpm)	i (i)	M2 (Nm)	Pm (kW)	fra (kN)	N2 (rpm)	i (i)	M2 (Nm)	Pm (kW)	fra (kN)		
4	5		2900											64		6470	42.49	30.70	65						
			1450												32	45.6	7965	26.15	38.90	32	45.0	15873	52.86	39.1	
			960																	21		16216	35.12	47.3	
			725																	16		16286	26.55	53.6	
5	0		2900											56		7369	42.49	31.10	60						
			1450												28	51.9	9073	26.16	39.50	30	48.6	16031	49.43	40.50	
			960																	18		16153	32.39	49.20	
			725																	14		16222	24.49	55.70	
5	6		2900											52		6965	37.47	32.70	50			14174	72.85	33.30	
			1450												26	55.7	8575	23.06	41.50	25	58.3	16169	41.55	43.80	
			960																	17		16281	27.21	53.00	
			725																	13		16343	20.56	60.00	
6	3		2900											46		7933	37.46	33.20	46			15310	72.85	32.10	
			1450												23	63.4	9767	23.06	42.10	23	62.9	16108	38.22	45.60	
			960																	15		16216	25.09	55.10	
			725																	11		16277	18.96	62.20	
7	1		2900											40		7641	31.67	35.60	40			15403	63.92	35.60	
			1450												20	72.3	9408	19.50	45.20	20	72.2	16227	33.67	48.20	
			960																	13		16328	22.03	58.20	
			725																	10		16385	16.54	62.20	
8	0		2900											35		8704	31.67	36.20	37			15958	61.31	36.60	
			1450												18	82.3	10617	19.32	46.00	19	78.0	16164	31.05	50.20	
			960																	12		16263	20.32	60.40	
			725																	9		16317	15.34	62.20	
9	0		2900											32		8354	27.63	38.3	31			16102	51.61	39.5	
			1450												16	90.6	10120	16.73	48.70	16	93.4	16290	26.11	54.00	
			960																	11		16380	17.07	62.20	
			725																	8		16430	12.89	62.20	
1	0	0	2900	28		4130	13.34	32.00	28			6370	19.62	43.00	28		9516	27.63	38.80	29			16043	47.61	41.20
			1450	14	102.5	4130	6.67	32.00	14	102.8	6370	9.81	43.00	14	103.2	10617	15.41	50.60	14	100.9	16226	24.08	56.10		
			960	9		4130	4.42	32.00	9		6370	6.49	43.00	9		10617	10.02	56.00	10		16313	15.74	62.20		
			725	7		4130	3.34	32.00	7		6370	4.91	43.00	7		10617	7.54	56.00	7		16361	11.88	62.20		
1	1	2	2900	25		4130	12.00	32.00	25			6400	17.74	43.00	26		8801	23.76	41.40	25			16166	41.96	43.60
			1450	12	113.9	4130	6.00	32.00	13	114.2	6400	8.87	43.00	13	110.9	10120	13.66	53.00	13	115.4	16337	21.20	59.20		
			960	8		4130	3.97	32.00	8		6400	5.87	43.00	9		10120	8.88	56.00	8		16417	13.85	62.20		
			725	6		4130	3.00	32.00	6		6400	4.44	43.00	7		10120	6.69	56.00	6		16463	10.46	62.20		
1	2	5	2900	21		4220	10.16	32.00	22			7250	17.80	43.00	23		10024	23.76	41.80	23			16105	38.70	45.40
			1450	10	132.3	4220	5.08	32.00	11	129.5	7250	8.90	43.00	11	126.4	10617	12.58	55.10	12	124.6	16271	19.55	61.40		
			960	7		4220	3.36	32.00	7		7250	5.89	43.00	8		10617	8.18	56.00	8		16349	12.77	62.20		
			725	5		4220	2.54	32.00	6		7250	4.45	43.00	6		10617	6.16	56.00	6		16393	9.64	62.20		
1	4	0	2900	19.728		4220	9.14	32.00	20			7250	16.02	43.00	21		9664	20.56	44.40	21			16219	34.72	47.50
			1450	9.864	147.0	4220	4.57	32.00	10	143.9	7250	8.01	43.00	10	140.8	10120	10.76	56.00	10	139.9	16375	17.53	62.20		
			960	6.531		4220	3.03	32.00	7		7250	5.30	43.00	7		10120	7.00	56.00	7		16449	11.45	62.20		
			725	4.932		4220	2.29	32.00	5		7250	4.01	43.00	5		10120	5.27	56.00	5		16490	8.64	62.20		

SERIES F

TRIPLE REDUCTION RATINGS

Note: Input Power, Pm may exceed thermal limit,
Check thermal power

Pm - Input Power (kW)
M2 - Output Torque (Nm)
i - Exact Ratio (:1)
N2 - Output Speed (rpm)
fra - Overhung Load (kN)

Column Entry			Input Speed N1 (rpm)	F0931					F1031					F1131					F1231				
				N2 (rpm)	i (i)	M2 (Nm)	Pm (kW)	fra (kN)	N2 (rpm)	i (i)	M2 (Nm)	Pm (kW)	fra (kN)	N2 (rpm)	i (i)	M2 (Nm)	Pm (kW)	fra (kN)	N2 (rpm)	i (i)	M2 (Nm)	Pm (kW)	fra (kN)
6	7	8																					
			2900	18		4310	8.52	32.00	18		6400	12.44	43.00	18		10617	19.83	45.50	19		16156	32.03	49.50
1	6	0	1450	9	160.8	4310	4.26	32.00	9	162.9	6400	6.22	43.00	9	160.4	10617	9.91	56.00	10	151.1	16308	16.16	62.20
			960	5		4310	2.82	32.00	6		6400	4.12	43.00	6		10617	6.45	56.00	6		16379	10.56	62.20
			725	4		4310	2.13	32.00	4		6400	3.11	43.00	5		10617	4.85	56.00	5		16409	7.97	62.20
			2900	16		4310	7.70	32.00	15		6400	10.80	43.00	16		10120	17.02	48.40	16		16283	26.90	53.30
1	8	0	1450	8	177.5	4310	3.85	32.00	8	187.7	6400	5.40	43.00	8	178.1	10120	8.51	56.00	8	181.3	16421	13.56	62.20
			960	5		4310	2.55	32.00	5		6400	3.58	43.00	5		10120	5.53	56.00	5		16486	8.86	62.20
			725	4		4310	1.93	32.00	4		6400	2.70	43.00	4		10120	4.17	56.00	4		16523	6.68	62.20
			2900	13		4230	6.48	32.00	14		7250	11.24	43.00	14		10617	15.68	50.30	15		16219	24.81	55.40
2	0	0	1450	6	207.7	4230	3.24	32.00	7	205.2	7250	5.62	43.00	7	202.8	10617	7.84	56.00	7	195.8	16353	12.51	62.20
			960	4		4230	2.15	32.00	5		7250	3.72	43.00	5		10617	5.10	56.00	5		16416	8.17	62.20
			725	3		4230	1.62	32.00	4		7250	2.81	43.00	4		10617	3.84	56.00	4		16451	6.16	62.20
			2900	12		4230	5.86	32.00	12		7250	9.76	43.00	13		10120	13.44	53.30	13		16334	21.31	59.00
2	2	5	1450	6	229.3	4230	2.93	32.00	6	236.4	7250	4.88	43.00	6	225.5	10120	6.72	56.00	6	229.5	16459	10.74	62.20
			960	4		4230	1.94	32.00	4		7250	3.23	43.00	4		10120	4.37	56.00	4		16517	7.01	62.20
			725	3		4230	1.47	32.00	3		7250	2.44	43.00	3		10120	3.29	56.00	3		16549	5.28	62.20
			2900	11.876		4310	5.62	32.00	11		6400	8.00	43.00	11		10617	12.38	55.50	12		16289	19.65	61.30
2	5	0	1450	5.938	244.2	4310	2.81	32.00	6	259.9	6400	4.00	43.00	6	256.9	10617	6.19	56.00	6	247.9	16389	9.90	62.20
			960	3.931		4310	1.86	32.00	4		6400	2.65	43.00	4		10617	4.03	56.00	4		16445	6.46	62.20
			725	2.969		4310	1.41	32.00	3		6400	2.00	43.00	3		10617	3.03	56.00	3		16447	4.87	62.20
			2900	10		4310	5.00	32.00	11		6400	7.46	43.00	10		10120	10.93	56.00	10		16379	17.19	62.20
2	8	0	1450	5	274.6	4310	2.50	32.00	5	272.7	6400	3.73	43.00	5	277.3	10120	5.47	56.00	5	285.3	16489	8.65	62.20
			960	3		4310	1.66	32.00	4		6400	2.47	43.00	3		10120	3.55	56.00	3		16542	5.65	62.20
			725	2		4310	1.25	32.00	3		6400	1.87	43.00	3		10120	2.68	56.00	3		16560	4.25	62.20
			2900	9		4230	4.28	32.00	9		7250	7.22	43.00	9		10617	10.07	56.00	9		16311	15.85	62.20
3	1	5	1450	4	315.4	4230	2.14	32.00	5	319.8	7250	3.61	43.00	5	315.8	10617	5.03	56.00	5	308.2	16419	7.98	62.20
			960	3		4230	1.42	32.00	3		7250	2.39	43.00	3		10617	3.27	56.00	3		16470	5.20	62.20
			725	2		4230	1.07	32.00	2		7250	1.81	43.00	2		10617	2.46	56.00	2		16498	3.92	62.20
			2900	8		4230	3.80	32.00	8		7250	6.74	43.00										
3	6	0	1450	4	354.7	4230	1.90	32.00	4	343.6	7250	3.37	43.00										
			960	2		4230	1.26	32.00	3		7250	2.23	43.00										
			725	2		4230	0.95	32.00	2		7250	1.69	43.00										

SERIES F

QUAD REDUCTION RATINGS

Note: Input Power, Pm may exceed thermal limit,
Check thermal power

Pm - Input Power (kW)
M2 - Output Torque (Nm)
i - Exact Ratio (:1)
N2 - Output Speed (rpm)
fra - Overhung Load (kN)

Column Entry			Input Speed N1 (rpm)	F0342					F0442					F0542					F0642								
				N2 (rpm)	i (i)	M2 (Nm)	Pm (kW)	fra (kN)	N2 (rpm)	i (i)	M2 (Nm)	Pm (kW)	fra (kN)	N2 (rpm)	i (i)	M2 (Nm)	Pm (kW)	fra (kN)	N2 (rpm)	i (i)	M2 (Nm)	Pm (kW)	fra (kN)				
3	2	0	2900														9.22	314	651	0.66	9.2						
			1450																4.61	651	0.33	9.2					
			960																	3.05	651	0.22	9.2				
			720																	2.29	651	0.16	9.2				
3	6	0	2900														8.24	352	679	0.62	9.2						
			1450																4.12	679	0.31	9.2					
			960																	2.73	679	0.20	9.2				
			720																	2.05	679	0.15	9.2				
4	0	0	2900	7.07	410	375	0.29	7.1	7.07	410	375	0.29	7.1	7.02	413	679	0.53	9.2	7.18	404	838	0.66	14.0				
			1450	3.54		375	0.15	7.1	3.54		375	0.15	7.1	3.51		679	0.26	9.2	3.59		838	0.33	14.0				
			960	2.34		375	0.10	7.1	2.34		375	0.10	7.1	2.33		679	0.17	9.2	2.38		838	0.22	14.0				
			720	1.76		375	0.073	7.1	1.76		375	0.07	7.1	1.74		679	0.13	9.2	1.78		838	0.16	14.0				
4	5	0	2900	6.36	456	375	0.26	7.1	6.36	456	375	0.26	7.1	6.53	444	679	0.49	9.2	6.52	445	838	0.60	14.0				
			1450	3.18		375	0.13	7.1	3.18		375	0.13	7.1	3.26		679	0.24	9.2	3.26		838	0.30	14.0				
			960	2.10		375	0.087	7.1	2.10		375	0.09	7.1	2.16		679	0.16	9.2	2.16		838	0.20	14.0				
			720	1.58		375	0.065	7.1	1.58		375	0.07	7.1	1.62		679	0.12	9.2	1.62		838	0.15	14.0				
5	0	0	2900	5.77	503	375	0.24	7.1	5.77	503	375	0.24	7.1	5.93	489	679	0.44	9.2	5.82	498	881	0.57	14.0				
			1450	2.88		375	0.12	7.1	2.88		375	0.12	7.1	2.96		679	0.22	9.2	2.91		881	0.28	14.0				
			960	1.91		375	0.079	7.1	1.91		375	0.08	7.1	1.96		679	0.15	9.2	1.93		881	0.19	14.0				
			720	1.43		375	0.059	7.1	1.43		375	0.06	7.1	1.47		679	0.11	9.2	1.45		881	0.14	14.0				
5	6	0	2900	5.02	578	393	0.22	7.1	5.02	578	393	0.22	7.1	5.15	563	679	0.39	9.2	5.08	571	893	0.50	14.0				
			1450	2.51		393	0.109	7.1	2.51		393	0.11	7.1	2.58		679	0.19	9.2	2.54		893	0.25	14.0				
			960	1.66		393	0.072	7.1	1.66		393	0.07	7.1	1.71		679	0.13	9.2	1.68		893	0.17	14.0				
			720	1.25		393	0.054	7.1	1.25		393	0.054	7.1	1.28		679	0.10	9.2	1.26		893	0.12	14.0				
6	3	0	2900	4.55	637	393	0.20	7.1	4.55	637	393	0.20	7.1	4.74	612	679	0.35	9.2	4.61	629	893	0.45	14.0				
			1450	2.28		393	0.099	7.1	2.28		393	0.10	7.1	2.37		679	0.18	9.2	2.31		893	0.23	14.0				
			960	1.51		393	0.065	7.1	1.51		393	0.07	7.1	1.57		679	0.12	9.2	1.53		893	0.15	14.0				
			720	1.13		393	0.049	7.1	1.13		393	0.049	7.1	1.18		679	0.09	9.2	1.14		893	0.11	14.0				
7	0	0	2900	4.14	701	393	0.18	7.1	4.14	701	393	0.18	7.1	4.18	694	679	0.31	9.2	4.01	724	893	0.39	14.0				
			1450	2.07		393	0.090	7.1	2.07		393	0.09	7.1	2.09		679	0.16	9.2	2.00		893	0.20	14.0				
			960	1.37		393	0.059	7.1	1.37		393	0.059	7.1	1.38		679	0.10	9.2	1.33		893	0.13	14.0				
			720	1.03		393	0.044	7.1	1.03		393	0.044	7.1	1.04		679	0.08	9.2	1.04		893	0.10	14.0				
8	0	0	2900	3.53	821	393	0.15	7.1	3.53	821	393	0.15	7.1	3.46	837	679	0.26	9.2	3.69	787	893	0.36	14.0				
			1450	1.77		393	0.076	7.1	1.77		393	0.08	7.1	1.73		679	0.13	9.2	1.84		893	0.18	14.0				
			960	1.17		393	0.051	7.1	1.17		393	0.051	7.1	1.15		679	0.09	9.2	1.22		893	0.12	14.0				
			720	0.88		393	0.038	7.1	0.88		393	0.038	7.1	0.86		679	0.06	9.2	0.92		893	0.09	14.0				
9	0	0	2900	3.17	915	392	0.14	7.1	3.17	915	392	0.14	7.1	3.11	932	675	0.23	9.2	3.25	892	907	0.32	14.0				
			1450	1.58		392	0.068	7.1	1.58		392	0.07	7.1	1.56		675	0.12	9.2	1.62		907	0.16	14.0				
			960	1.05		392	0.045	7.1	1.05		392	0.045	7.1	1.03		675	0.08	9.2	1.08		907	0.11	14.0				
			720	0.79		392	0.034	7.1	0.79		392	0.034	7.1	0.77		675	0.06	9.2	0.81		907	0.08	14.0				

SERIES F

QUAD REDUCTION RATINGS

Note: Input Power, Pm may exceed thermal limit,
Check thermal power

Pm - Input Power (kW)
M2 - Output Torque (Nm)
i - Exact Ratio (:1)
N2 - Output Speed (rpm)
fra - Overhung Load (kN)

Column Entry			Input Speed N1 (rpm)	F0342					F0442					F0542					F0642				
				N2 (rpm)	i (i)	M2 (Nm)	Pm (kW)	fra (kN)	N2 (rpm)	i (i)	M2 (Nm)	Pm (kW)	fra (kN)	N2 (rpm)	i (i)	M2 (Nm)	Pm (kW)	fra (kN)	N2 (rpm)	i (i)	M2 (Nm)	Pm (kW)	fra (kN)
6	7	8																					
			2900	2.91	998	402	0.13	7.1	2.91	998	402	0.13	7.1	2.83	1026	679	0.21	9.2	2.95	983	907	0.30	11.30
1	0	C	1450	1.45		402	0.064	7.1	1.45		402	0.06	7.1	1.41		679	0.11	9.2	1.48		907	0.15	11.30
			960	0.96		402	0.043	7.1	0.96		402	0.043	7.1	0.94		679	0.07	9.2	0.98		907	0.10	11.30
			720	0.72		402	0.032	7.1	0.72		402	0.032	7.1	0.70		679	0.053	9.2	0.73		907	0.07	11.30
			2900	2.64	1098	402	0.12	7.1	2.64	1098	402	0.12	7.1	2.53	1148	679	0.19	9.2	2.57	1130	907	0.26	11.30
1	1	C	1450	1.32		402	0.059	7.1	1.32		402	0.06	7.1	1.26		679	0.09	9.2	1.28		907	0.13	11.30
			960	0.87		402	0.039	7.1	0.87		402	0.039	7.1	0.84		679	0.063	9.2	0.85		907	0.08	11.30
			720	0.66		402	0.029	7.1	0.66		402	0.029	7.1	0.63		679	0.047	9.2	0.64		907	0.064	11.30
			2900	2.34	1237	402	0.104	7.1	2.34	1237	402	0.10	7.1	2.46	1180	679	0.18	9.2	2.34	1238	907	0.23	11.30
1	2	C	1450	1.17		402	0.052	7.1	1.17		402	0.052	7.1	1.23		679	0.09	9.2	1.17		907	0.12	11.30
			960	0.78		402	0.034	7.1	0.78		402	0.034	7.1	0.81		679	0.061	9.2	0.78		907	0.08	11.30
			720	0.58		402	0.026	7.1	0.58		402	0.026	7.1	0.61		679	0.046	9.2	0.58		907	0.058	11.30
			2900	2.00	1449	402	0.089	7.1	2.00	1449	402	0.09	7.1	2.11	1377	679	0.16	9.2	2.16	1346	907	0.22	11.30
1	4	C	1450	1.00		402	0.044	7.1	1.00		402	0.044	7.1	1.05		679	0.08	9.2	1.08		907	0.11	11.30
			960	0.66		402	0.029	7.1	0.66		402	0.029	7.1	0.70		679	0.052	9.2	0.71		907	0.071	11.30
			720	0.50		402	0.022	7.1	0.50		402	0.022	7.1	0.52		679	0.039	9.2	0.54		907	0.053	11.30
			2900	1.88	1543	402	0.083	7.1	1.88	1543	402	0.08	7.1	1.87	1552	679	0.14	9.2	1.80	1615	907	0.18	11.30
1	6	C	1450	0.94		402	0.042	7.1	0.94		402	0.042	7.1	0.93		679	0.07	9.2	0.90		907	0.09	11.30
			960	0.62		402	0.028	7.1	0.62		402	0.028	7.1	0.62		679	0.046	9.2	0.59		907	0.059	11.30
			720	0.47		402	0.021	7.1	0.47		402	0.021	7.1	0.46		679	0.035	9.2	0.45		907	0.045	11.30
			2900	1.61	1799	402	0.071	7.1	1.61	1799	402	0.07	7.1	1.57	1848	675	0.12	9.2	1.64	1770	907	0.16	11.30
1	8	C	1450	0.81		402	0.036	7.1	0.81		402	0.036	7.1	0.78		675	0.058	9.2	0.82		907	0.08	11.30
			960	0.53		402	0.024	7.1	0.53		402	0.024	7.1	0.52		675	0.039	9.2	0.54		907	0.054	11.30
			720	0.40		402	0.018	7.1	0.40		402	0.018	7.1	0.39		675	0.029	9.2	0.41		907	0.041	11.30
			2900	1.43	2027	402	0.063	7.1	1.43	2027	402	0.06	7.1	1.39	2082	675	0.10	9.2	1.45	1995	907	0.15	11.30
2	0	C	1450	0.72		402	0.032	7.1	0.72		402	0.032	7.1	0.70		675	0.052	9.2	0.73		907	0.07	11.30
			960	0.47		402	0.021	7.1	0.47		402	0.021	7.1	0.46		675	0.034	9.2	0.48		907	0.048	11.30
			720	0.36		402	0.016	7.1	0.36		402	0.016	7.1	0.35		675	0.026	9.2	0.36		907	0.036	11.30
			2900	1.29	2252	402	0.057	7.1	1.29	2252	402	0.057	7.1	1.29	2242	675	0.10	9.2	1.33	2184	907	0.13	11.30
2	2	C	1450	0.64		402	0.029	7.1	0.64		402	0.029	7.1	0.65		675	0.048	9.2	0.66		907	0.066	11.30
			960	0.43		402	0.019	7.1	0.43		402	0.019	7.1	0.43		675	0.032	9.2	0.44		907	0.044	11.30
			720	0.32		402	0.014	7.1	0.32		402	0.014	7.1	0.32		675	0.024	9.2	0.33		907	0.033	11.30
			2900	1.20	2407	402	0.053	7.1	1.20	2407	402	0.053	7.1	1.20	2421	675	0.09	9.2	1.14	2539	907	0.11	11.30
2	5	C	1450	0.60		402	0.027	7.1	0.60		402	0.027	7.1	0.60		675	0.045	9.2	0.57		907	0.057	11.30
			960	0.40		402	0.018	7.1	0.40		402	0.018	7.1	0.40		675	0.030	9.2	0.38		907	0.038	11.30
			720	0.30		402	0.013	7.1	0.30		402	0.013	7.1	0.30		675	0.022	9.2	0.28		907	0.028	11.30
			2900	1.05	2759	402	0.047	7.1	1.05	2759	402	0.047	7.1	1.06	2747	675	0.08	9.2	1.01	2882	907	0.10	11.30
2	8	C	1450	0.53		402	0.023	7.1	0.53		402	0.023	7.1	0.53		675	0.039	9.2	0.50		907	0.050	11.30
			960	0.35		402	0.015	7.1	0.35		402	0.015	7.1	0.35		675	0.026	9.2	0.33		907	0.033	11.30
			720	0.26		402	0.012	7.1	0.26		402	0.012	7.1	0.26		675	0.019	9.2	0.25		907	0.025	11.30

SERIES F

QUAD REDUCTION RATINGS

Note: Input Power, Pm may exceed thermal limit,
Check thermal power

Pm - Input Power (kW)
M2 - Output Torque (Nm)
i - Exact Ratio (:1)
N2 - Output Speed (rpm)
fra - Overhung Load (kN)

Column Entry			Input Speed N1 (rpm)	F0342					F0442					F0542					F0642				
				N2 (rpm)	i (i)	M2 (Nm)	Pm (kW)	fra (kN)	N2 (rpm)	i (i)	M2 (Nm)	Pm (kW)	fra (kN)	N2 (rpm)	i (i)	M2 (Nm)	Pm (kW)	fra (kN)	N2 (rpm)	i (i)	M2 (Nm)	Pm (kW)	fra (kN)
6	7	8	2900	0.92	3153	377	0.038	7.1	0.92	3578	377	0.038	7.1	0.93	3123	675	0.07	9.2	0.93	3112	869	0.09	11.30
			1450	0.46		377	0.019	7.1	0.41		377	0.019	7.1	0.46		675	0.035	9.2	0.47		869	0.045	11.30
			960	0.30		377	0.013	7.1	0.27		377	0.013	7.1	0.31		675	0.023	9.2	0.31		869	0.030	11.30
			720	0.23		377	0.009	7.1	0.20		377	0.009	7.1	0.23		675	0.017	9.2	0.23		869	0.022	11.30
3	2	C	2900	0.81	3578	339	0.030	7.1	0.81	3578	339	0.030	7.1	0.83	3481	512	0.047	9.2	0.82	3532	869	0.08	11.30
			1450	0.41		339	0.015	7.1	0.41		339	0.015	7.1	0.42		512	0.024	9.2	0.41		869	0.039	11.30
			960	0.27		339	0.010	7.1	0.27		339	0.010	7.1	0.28		512	0.016	9.2	0.27		869	0.026	11.30
			720	0.20		339	0.008	7.1	0.20		339	0.008	7.1	0.21		512	0.012	9.2	0.20		869	0.020	11.30
4	0	C	2900	0.71	4102	339	0.026	7.1	0.71	4102	339	0.026	7.1	0.74	3904	365	0.030	9.2	0.74	3937	660	0.05	11.30
			1450	0.35		339	0.013	7.1	0.35		339	0.013	7.1	0.37		365	0.015	9.2	0.37		660	0.027	11.30
			960	0.23		339	0.009	7.1	0.23		339	0.009	7.1	0.25		365	0.010	9.2	0.24		660	0.018	11.30
			720	0.18		339	0.007	7.1	0.18		339	0.007	7.1	0.18		365	0.007	9.2	0.18		660	0.013	11.30
4	5	C	2900	0.62	4663	302	0.021	7.1	0.62	4663	302	0.021	7.1							4415	470	0.034	11.30
			1450	0.31		302	0.010	7.1	0.31		302	0.010	7.1						0.33		470	0.017	11.30
			960	0.21		302	0.007	7.1	0.21		302	0.007	7.1						0.22		470	0.011	11.30
			720	0.15		302	0.005	7.1	0.15		302	0.005	7.1						0.16		470	0.008	11.30
5	0	C	2900	0.55	5299	302	0.018	7.1	0.55	5299	302	0.018	7.1							5019	470	0.030	11.30
			1450	0.27		302	0.009	7.1	0.27		302	0.009	7.1						0.29		470	0.015	11.30
			960	0.18		302	0.006	7.1	0.18		302	0.006	7.1						0.19		470	0.010	11.30
			720	0.14		302	0.005	7.1	0.14		302	0.005	7.1						0.14		470	0.007	11.30
5	6	C	2900																				
			1450																				
			960																				
			720																				

SERIES F

QUAD REDUCTION RATINGS

Note: Input Power, Pm may exceed thermal limit,
Check thermal power

Pm - Input Power (kW)
M2 - Output Torque (Nm)
i - Exact Ratio (:1)
N2 - Output Speed (rpm)
fra - Overhung Load (kN)

Column Entry			Input Speed N1 (rpm)	F0742					F0842					F0941					F1041					
				N2	i	M2	Pm	fra	N2	i	M2	Pm	fra	N2	i	M2	Pm	fra	N2	i	M2	Pm	fra	
6	7	8	(rpm)	(rpm)	(i)	(Nm)	(kW)	(kN)	(rpm)	(i)	(Nm)	(kW)	(kN)	(rpm)	(i)	(Nm)	(kW)	(kN)	(rpm)	(i)	(Nm)	(kW)	(kN)	
3	2	0	2900																					
			1450																					
			960																					
			720																					
			2900																					
			1450																					
3	6	0	960																					
			720																					
			2900																					
4	0	0	2900	7.18	404	1590	1.26	17.0	7.33	396	2700	2.18	19.70	7.33	396	4230	3.42	32.90	7.24	401	7250	5.78	43.30	
			1450	3.59		1590	0.63	17.0	3.66		2700	1.09	19.70	3.66		4230	1.71	32.90	3.62		7250	2.89	43.30	
			960	2.38		1590	0.42	17.0	2.43		2700	0.72	19.70	2.43		4230	1.13	32.90	2.40		7250	1.91	43.30	
			720	1.78		1590	0.31	17.0	1.82		2700	0.54	19.70	1.82		4230	0.85	32.90	1.80		7250	1.44	43.30	
4	5	0	2900	6.25	464	1720	1.18	17.0	6.30	460	2700	1.87	19.70	6.30	460	4230	2.94	32.90	6.51	445	7250	5.20	43.30	
			1450	3.12		1720	0.59	17.0	3.15		2700	0.94	19.70	3.15		4230	1.47	32.90	3.26		7250	2.60	43.30	
			960	2.07		1720	0.39	17.0	2.09		2700	0.62	19.70	2.09		4230	0.97	32.90	2.16		7250	1.72	43.30	
			720	1.55		1720	0.29	17.0	1.56		2700	0.47	19.70	1.56		4230	0.73	32.90	1.62		7250	1.29	43.30	
5	0	0	2900	5.43	534	1720	1.03	17.0	5.92	490	2770	1.81	19.70	5.68	511	4230	2.65	32.90	5.92	490	7250	4.73	43.30	
			1450	2.71		1720	0.51	17.0	2.96		2770	0.90	19.70	2.84		4230	1.32	32.90	2.96		7250	2.37	43.30	
			960	1.80		1720	0.34	17.0	1.96		2770	0.60	19.70	1.88		4230	0.88	32.90	1.96		7250	1.57	43.30	
			720	1.35		1720	0.26	17.0	1.47		2770	0.45	19.70	1.41		4230	0.66	32.90	1.47		7250	1.17	43.30	
5	6	0	2900	4.99	581	1720	0.95	17.0	5.09	570	2770	1.55	19.70	4.88	594	4230	2.28	32.90	5.15	563	7250	4.12	43.30	
			1450	2.50		1720	0.47	17.0	2.54		2770	0.78	19.70	2.44		4230	1.14	32.90	2.58		7250	2.06	43.30	
			960	1.65		1720	0.31	17.0	1.68		2770	0.51	19.70	1.62		4230	0.75	32.90	1.71		7250	1.36	43.30	
			720	1.24		1720	0.24	17.0	1.26		2770	0.39	19.70	1.21		4230	0.56	32.90	1.28		7250	1.02	43.30	
6	3	0	2900	4.40	658	1860	0.90	17.0	4.55	638	2770	1.39	19.70	4.36	665	4230	2.03	32.90	4.54	638	7250	3.63	43.30	
			1450	2.20		1860	0.45	17.0	2.27		2770	0.69	19.70	2.18		4230	1.02	32.90	2.27		7250	1.82	43.30	
			960	1.46		1860	0.30	17.0	1.51		2770	0.46	19.70	1.44		4230	0.67	32.90	1.50		7250	1.20	43.30	
			720	1.09		1860	0.22	17.0	1.13		2770	0.34	19.70	1.08		4230	0.50	32.90	1.13		7250	0.90	43.30	
7	0	0	2900	3.99	726	1890	0.83	17.0	4.27	680	2770	1.30	19.70	4.09	709	4230	1.91	32.90	4.12	704	7250	3.29	43.30	
			1450	2.00		1890	0.42	17.0	2.13		2770	0.65	19.70	2.05		4230	0.95	32.90	2.06		7250	1.65	43.30	
			960	1.32		1890	0.28	17.0	1.41		2770	0.43	19.70	1.35		4230	0.63	32.90	1.36		7250	1.09	43.30	
			720	0.99		1890	0.21	17.0	1.06		2770	0.32	19.70	1.02		4230	0.47	32.90	1.02		7250	0.82	43.30	
8	0	0	2900	3.49	832	1890	0.73	17.0	3.60	806	2770	1.10	19.70	3.45	840	4230	1.61	32.90	3.60	806	7250	2.87	43.30	
			1450	1.74		1890	0.36	17.0	1.80		2770	0.55	19.70	1.73		4230	0.80	32.90	1.80		7250	1.44	43.30	
			960	1.15		1890	0.24	17.0	1.19		2770	0.36	19.70	1.14		4230	0.53	32.90	1.19		7250	0.95	43.30	
			720	0.87		1890	0.18	17.0	0.89		2770	0.27	19.70	0.86		4230	0.40	32.90	0.89		7250	0.71	43.30	
9	0	0	2900	3.07	944	1890	0.64	17.0	3.19	910	3200	1.12	19.70	3.13	927	4230	1.46	32.90	3.14	925	7250	2.51	43.30	
			1450	1.54		1890	0.32	17.0	1.59		3200	0.56	19.70	1.56		4230	0.73	32.90	1.57		7250	1.25	43.30	
			960	1.02		1890	0.21	17.0	1.06		3200	0.37	19.70	1.04		4230	0.48	32.90	1.04		7250	0.83	43.30	
			720	0.76		1890	0.16	17.0	0.79		3200	0.28	19.70	0.78		4230	0.36	32.90	0.78		7250	0.62	43.30	

SERIES F

QUAD REDUCTION RATINGS

Note: Input Power, Pm may exceed thermal limit,
Check thermal power

Pm - Input Power (kW)
M2 - Output Torque (Nm)
i - Exact Ratio (:1)
N2 - Output Speed (rpm)
fra - Overhung Load (kN)

Column Entry			Input Speed N1 (rpm)	F0742					F0842					F0941					F1041				
				N2 (rpm)	i (i)	M2 (Nm)	Pm (kW)	fra (kN)	N2 (rpm)	i (i)	M2 (Nm)	Pm (kW)	fra (kN)	N2 (rpm)	i (i)	M2 (Nm)	Pm (kW)	fra (kN)	N2 (rpm)	i (i)	M2 (Nm)	Pm (kW)	fra (kN)
6	7	8	(rpm)	(rpm)	(i)	(Nm)	(kW)	(kN)	(rpm)	(i)	(Nm)	(kW)	(kN)	(rpm)	(i)	(Nm)	(kW)	(kN)	(rpm)	(i)	(Nm)	(kW)	(kN)
			2900	2.79		1890	0.58	17.0	2.85		3200	1.01	19.70	2.80		4230	1.30	32.90	2.77		7250	2.21	43.30
1	0	C	1450	1.39	1040	1890	0.29	17.0	1.42	1018	3200	0.50	19.70	1.40	1037	4230	0.65	32.90	1.38	1049	7250	1.10	43.30
			960	0.92		1890	0.19	17.0	0.94		3200	0.33	19.70	0.93		4230	0.43	32.90	0.92		7250	0.73	43.30
			720	0.69		1890	0.14	17.0	0.71		3200	0.25	19.70	0.69		4230	0.32	32.90	0.69		7250	0.55	43.30
			2900	2.66		1890	0.55	17.0	2.67		3200	0.94	19.70	2.62		4230	1.22	32.90	2.51		7250	2.00	43.30
1	1	C	1450	1.33	1090	1890	0.28	17.0	1.34	1085	3200	0.47	19.70	1.31	1105	4230	0.61	32.90	1.25	1157	7250	1.00	43.30
			960	0.88		1890	0.18	17.0	0.89		3200	0.31	19.70	0.87		4230	0.41	32.90	0.83		7250	0.66	43.30
			720	0.66		1890	0.14	17.0	0.66		3200	0.23	19.70	0.65		4230	0.30	32.90	0.62		7250	0.50	43.30
			2900	2.42		1890	0.51	17.0	2.43		3200	0.86	19.70	2.46		4230	1.15	32.90	2.19		7250	1.75	43.30
1	2	C	1450	1.21	1196	1890	0.25	17.0	1.22	1191	3200	0.43	19.70	1.23	1177	4230	0.57	32.90	1.09	1325	7250	0.87	43.30
			960	0.80		1890	0.17	17.0	0.81		3200	0.28	19.70	0.82		4230	0.38	32.90	0.72		7250	0.58	43.30
			720	0.60		1890	0.13	17.0	0.60		3200	0.21	19.70	0.61		4230	0.29	32.90	0.54		7250	0.43	43.30
			2900	2.15		1890	0.45	17.0	2.05		3200	0.72	19.70	2.08		4230	0.97	32.90	1.94		7250	1.55	43.30
1	4	C	1450	1.07	1350	1890	0.22	17.0	1.03	1412	3200	0.36	19.70	1.04	1395	4230	0.48	32.90	0.97	1498	7250	0.77	43.30
			960	0.71		1890	0.15	17.0	0.68		3200	0.24	19.70	0.69		4230	0.32	32.90	0.64		7250	0.51	43.30
			720	0.53		1890	0.11	17.0	0.51		3200	0.18	19.70	0.52		4230	0.24	32.90	0.48		7250	0.38	43.30
			2900	1.85		1890	0.38	17.0	1.82		3200	0.64	19.70	1.91		4230	0.89	32.90	1.85		7250	1.48	43.30
1	6	C	1450	0.92	1571	1890	0.19	17.0	0.91	1594	3200	0.32	19.70	0.95	1520	4230	0.44	32.90	0.93	1564	7250	0.74	43.30
			960	0.61		1890	0.13	17.0	0.60		3200	0.21	19.70	0.63		4230	0.29	32.90	0.61		7250	0.49	43.30
			720	0.46		1890	0.10	17.0	0.45		3200	0.16	19.70	0.47		4230	0.22	32.90	0.46		7250	0.37	43.30
			2900	1.64		1890	0.34	17.0	1.53		3200	0.54	19.70	1.61		4230	0.75	32.90	1.62		7250	1.29	43.30
1	8	C	1450	0.82	1770	1890	0.17	17.0	0.77	1890	3200	0.27	19.70	0.80	1802	4230	0.38	32.90	0.81	1792	7250	0.65	43.30
			960	0.54		1890	0.11	17.0	0.51		3200	0.18	19.70	0.53		4230	0.25	32.90	0.54		7250	0.43	43.30
			720	0.41		1890	0.08	17.0	0.38		3200	0.13	19.70	0.40		4230	0.19	32.90	0.40		7250	0.32	43.30
			2900	1.41		1890	0.29	17.0	1.44		3200	0.51	19.70	1.51		4230	0.70	32.90	1.43		7250	1.14	43.30
2	0	C	1450	0.71	2052	1890	0.15	17.0	0.72	2017	3200	0.25	19.70	0.75	1924	4230	0.35	32.90	0.72	2026	7250	0.57	43.30
			960	0.47		1890	0.10	17.0	0.48		3200	0.17	19.70	0.50		4230	0.23	32.90	0.47		7250	0.38	43.30
			720	0.35		1890	0.07	17.0	0.36		3200	0.13	19.70	0.37		4230	0.17	32.90	0.36		7250	0.28	43.30
			2900	1.25		1890	0.26	17.0	1.26		3200	0.45	19.70	1.33		4230	0.62	32.90	1.23		7250	0.99	43.30
2	2	C	1450	0.63	2312	1890	0.13	17.0	0.63	2293	3200	0.22	19.70	0.67	2180	4230	0.31	32.90	0.62	2349	7250	0.49	43.30
			960	0.42		1890	0.09	17.0	0.42		3200	0.15	19.70	0.44		4230	0.21	32.90	0.41		7250	0.33	43.30
			720	0.31		1890	0.065	17.0	0.31		3200	0.11	19.70	0.33		4230	0.15	32.90	0.31		7250	0.24	43.30
			2900	1.18		1890	0.25	17.0	1.16		3200	0.41	19.70	1.21		4230	0.57	32.90	1.15		7050	0.89	43.30
2	5	C	1450	0.59	2454	1890	0.12	17.0	0.58	2503	3200	0.20	19.70	0.61	2387	4230	0.28	32.90	0.57	2523	7050	0.45	43.30
			960	0.39		1890	0.08	17.0	0.38		3200	0.14	19.70	0.40		4230	0.19	32.90	0.38		7050	0.30	43.30
			720	0.29		1890	0.061	17.0	0.29		3200	0.10	19.70	0.30		4230	0.14	32.90	0.29		7050	0.22	43.30
			2900	1.04		1890	0.22	17.0	1.07		3200	0.38	19.70	1.03		4230	0.48	32.90	1.04		7250	0.83	43.30
2	8	C	1450	0.52	2785	1890	0.11	17.0	0.54	2703	3200	0.19	19.70	0.52	2815	4230	0.24	32.90	0.52	2801	7250	0.41	43.30
			960	0.34		1890	0.072	17.0	0.36		3200	0.13	19.70	0.34		4230	0.16	32.90	0.34		7250	0.27	43.30
			720	0.26		1890	0.054	17.0	0.27		3200	0.09	19.70	0.26		4230	0.12	32.90	0.26		7250	0.21	43.30

SERIES F

QUAD REDUCTION RATINGS

Note: Input Power, Pm may exceed thermal limit,
Check thermal power

Pm - Input Power (kW)
M2 - Output Torque (Nm)
i - Exact Ratio (:1)
N2 - Output Speed (rpm)
fra - Overhung Load (kN)

Column Entry			Input Speed N1 (rpm)	F0742					F0842					F0941					F1041				
				N2 (rpm)	i (i)	M2 (Nm)	Pm (kW)	fra (kN)	N2 (rpm)	i (i)	M2 (Nm)	Pm (kW)	fra (kN)	N2 (rpm)	i (i)	M2 (Nm)	Pm (kW)	fra (kN)	N2 (rpm)	i (i)	M2 (Nm)	Pm (kW)	fra (kN)
6	7	8																					
			2900	0.90		1650	0.16	17.0	0.90		3200	0.32	19.70	0.94		4230	0.44	32.90	0.95		7250	0.76	43.30
3	2	C	1450	0.45	3225	1650	0.08	17.0	0.45	3232	3200	0.16	19.70	0.47	3082	4230	0.22	32.90	0.47	3068	7250	0.38	43.30
			960	0.30		1650	0.054	17.0	0.30		3200	0.10	19.70	0.31		4230	0.15	32.90	0.31		7250	0.25	43.30
			720	0.22		1650	0.041	17.0	0.22		3200	0.08	19.70	0.23		4230	0.11	32.90	0.23		7250	0.19	43.30
			2900	0.79		1650	0.14	17.0	0.80		3200	0.28	19.70	0.79		4230	0.37	32.90	0.79		7250	0.63	43.30
3	6	C	1450	0.40	3660	1650	0.07	17.0	0.40	3628	3200	0.14	19.70	0.40	3656	4230	0.18	32.90	0.39	3681	7250	0.31	43.30
			960	0.26		1650	0.048	17.0	0.26		3200	0.09	19.70	0.26		4230	0.12	32.90	0.26		7250	0.21	43.30
			720	0.20		1650	0.036	17.0	0.20		3200	0.070	19.70	0.20		4230	0.092	32.90	0.20		7250	0.16	43.30
			2900	0.70		1650	0.13	17.0	0.73		3200	0.26	19.70	0.77		4230	0.36	32.90	0.68		7250	0.55	43.30
4	0	C	1450	0.35	4161	1650	0.06	17.0	0.37	3961	3200	0.13	19.70	0.38	3777	4230	0.18	32.90	0.34	4235	7250	0.27	43.30
			960	0.23		1650	0.042	17.0	0.24		3200	0.09	19.70	0.25		4230	0.12	32.90	0.23		7250	0.18	43.30
			720	0.17		1650	0.031	17.0	0.18		3200	0.064	19.70	0.19		4230	0.089	32.90	0.17		7250	0.14	43.30
			2900	0.62		1290	0.09	17.0	0.66		3200	0.23	19.70	0.69		4230	0.32	32.90	0.64		7050	0.50	43.30
4	5	C	1450	0.31	4679	1290	0.044	17.0	0.33	4415	3200	0.12	19.70	0.34	4210	4230	0.16	32.90	0.32	4550	7050	0.25	43.30
			960	0.21		1290	0.029	17.0	0.22		3200	0.08	19.70	0.23		4230	0.11	32.90	0.21		7050	0.16	43.30
			720	0.15		1290	0.022	17.0	0.16		3200	0.058	19.70	0.17		4230	0.080	32.90	0.16		7050	0.12	43.30
			2900	0.55		1100	0.07	17.0	0.59		3200	0.21	19.70	0.61		4230	0.29	32.90	0.62		7250	0.49	43.30
5	0	C	1450	0.27	5319	1100	0.033	17.0	0.29	4952	3200	0.10	19.70	0.31	4722	4230	0.14	32.90	0.31	4706	7250	0.25	43.30
			960	0.18		1100	0.022	17.0	0.19		3200	0.068	19.70	0.20		4230	0.095	32.90	0.20		7250	0.16	43.30
			720	0.14		1100	0.016	17.0	0.15		3200	0.051	19.70	0.15		4230	0.071	32.90	0.15		7250	0.12	43.30
			2900						0.51		2940	0.16	19.70	0.55		4220	0.25	32.90	0.57		7050	0.45	43.30
5	6	C	1450						0.25	5702	2940	0.08	19.70	0.27	5310	4220	0.13	32.90	0.29	5056	7050	0.22	43.30
			960						0.17		2940	0.055	19.70	0.18		4220	0.084	32.90	0.19		7050	0.15	43.30
			720						0.13		2940	0.041	19.70	0.14		4220	0.063	32.90	0.14		7050	0.11	43.30

SERIES F

DIMENSIONS

REDUCER

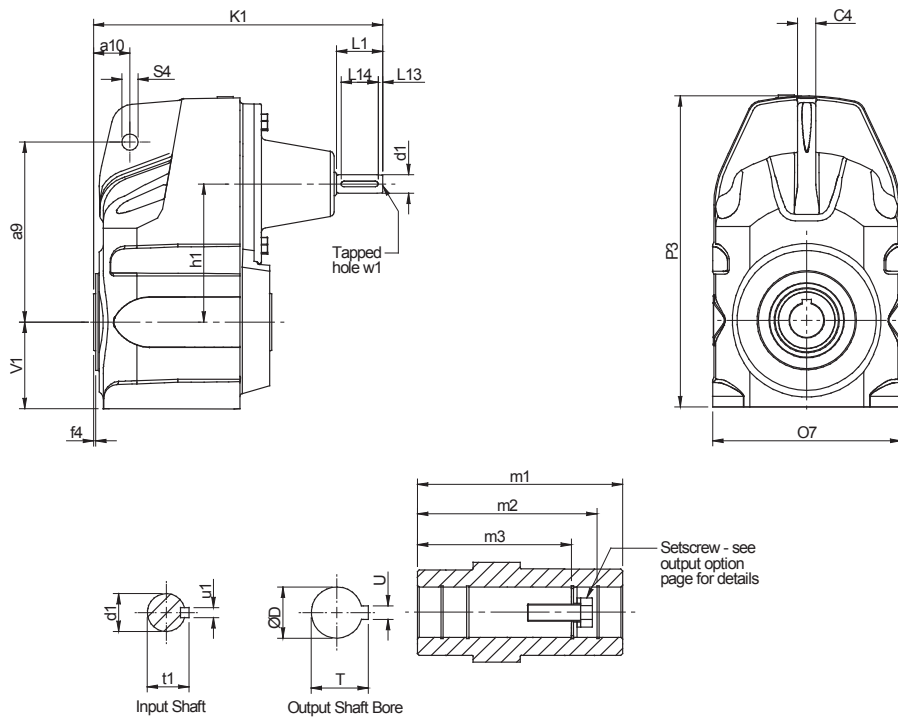

SERIES F

DIMENSIONS

REDUCER QUAD

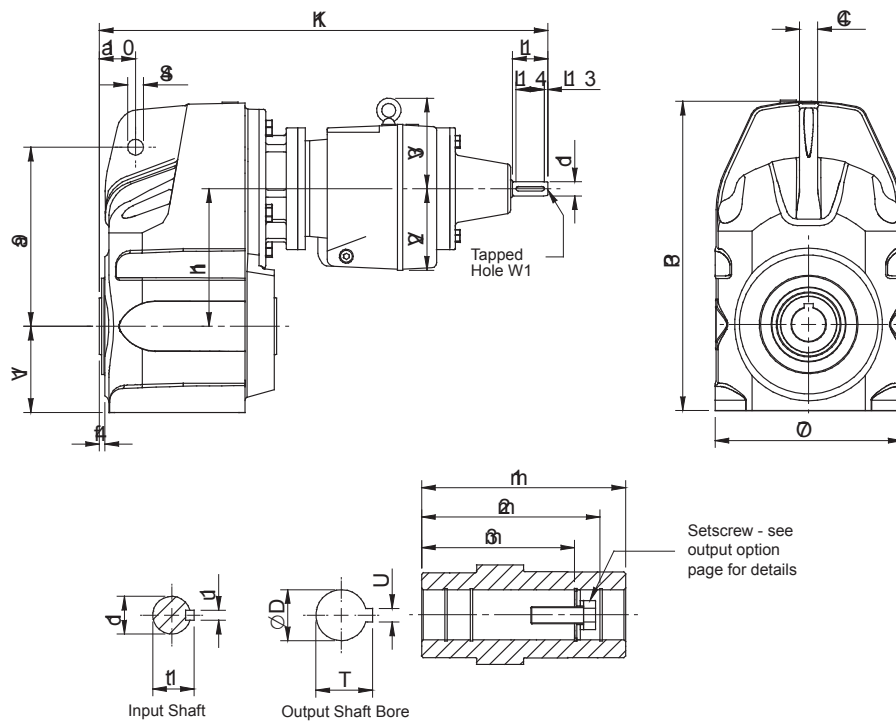

UNIT SIZE	a9	a10	C4	f4	h1	K1	O7	P3	S4	V1	V2	V3
F0342	158	32	16	5	121	438	171	273	15	76	76	74
F0442	170	32	16	5	121	438	171	273	15	76	76	74
F0542	198	41	16	5	144	490	206	318	15	80	91	90
F0642	218	41	16	6	165	501	231	365	15	101	91	90
F0742	278	50	20	7	200	536	282	442	24	127	91	90
F0842	346	62	26	3	243	614	346	536	24	156	115	93
F0941	395	70	30	5	274	663	400	612	27	175	115	93
F1041	485	88	36	5.5	332	750	470	748	27	216	140	155

UNIT SIZE	Input Shaft							Hollow Output Bore					
	d1	L1	L13	L14	t1	u1	w1	D	m1	m2	m3	T	U
F0342	16 k6	40	4	32	18	5	M5X12	30	156.5	122	105	33.5	8
F0442	16 k6	40	4	32	18	5	M5X12	35	156.5	132	122	38.5	10
F0542	16 k6	40	4	32	18	5	M5X12	40	179	174	142	43.5	12
F0642	16 k6	40	4	32	18	5	M5X12	40	205	174	156	43.5	12
F0742	16 k6	40	4	32	18	5	M5X12	50	233.5	198	183	54	14
F0842	19 k6	40	4	32	21.5	6	M6X16	60	270	230	210	64.6	18
F0941	19 k6	40	4	32	21.5	6	M6X16	70	330	270	-	75	20
F1041	24 k6	50	5	40	27	8	M8X19	80	370	313	-	85.5	22

Column 10 Entry

For reducer fan kit modules enter **S** in column 10

or if used in conjunction with a reducer backstop module kit **Y** CW rotation

Z CCW rotation

Dimensions of Fan Cooled Units

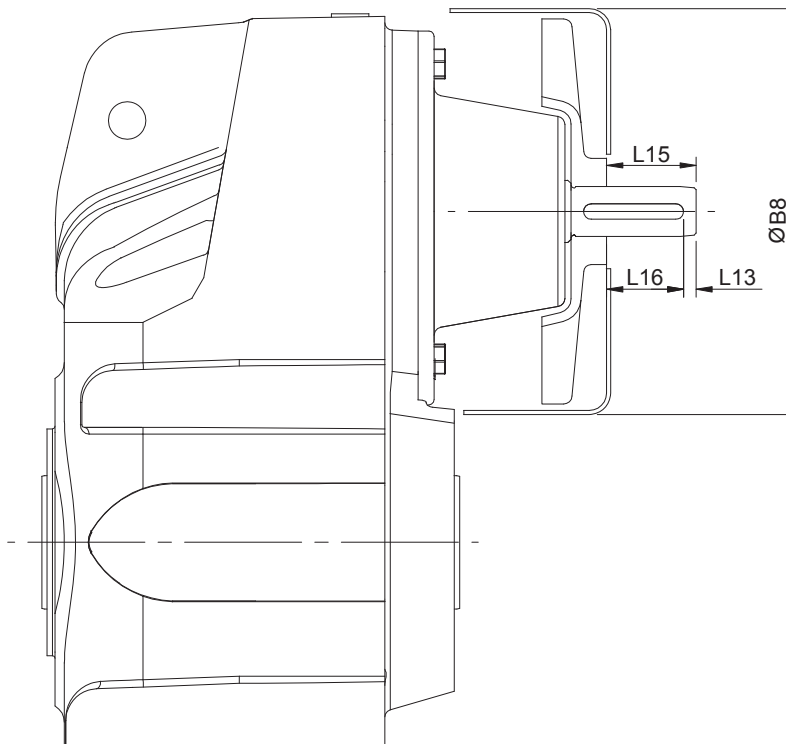

UNIT SIZE	ØB8	L13	L15	L16
F0722	225	5	35	30
F0822	265	5	45	40
F0921	320	5	65	60
F1021	380	10	95	85

SERIES F

REDUCER BACKSTOP MODULE

The reducer units listed below can be fitted with an internal backstop, this has no effect of the external unit size. The backstop device incorporates high quality centrifugal lift off sprags which are wear free above the lift off speed (n min). To ensure correct operation input speed must exceed lift off speed.

Suitable for ambient temperature -40°C to + 50°C

Column 10 Entry

For reducer backstop modules enter

W for CCW rotation (or Z if used in conjunction with a fan kit)
X for CW rotation (or Y if used in conjunction with a fan kit)

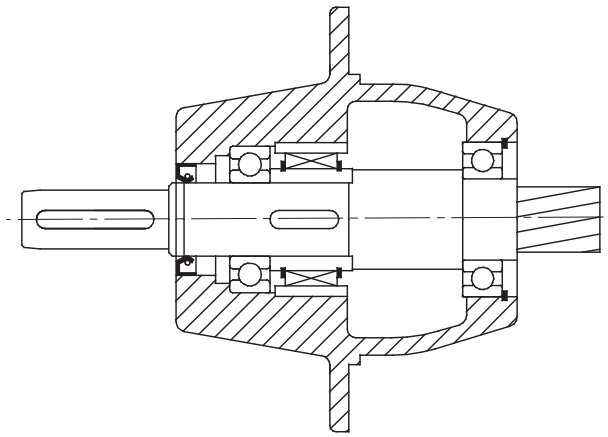

Unit Size	Lift Off Speed ('n' min) (at inputshaft) (rev/min)	Rated Locking Torque ('T max') (at inputshaft) (Nm)
F05	800	100
F06	800	100
F07	670	170
F08	670	170
F09	670	300
F10	670	300

Rotation of outputshaft must be specified when ordering as viewed from the outputshaft end (as shown in the diagram)

CW	-	Free Rotation	-	Clockwise
		Locked		Anticlockwise
AC	-	Free Rotation	-	Anticlockwise
		Locked		Clockwise

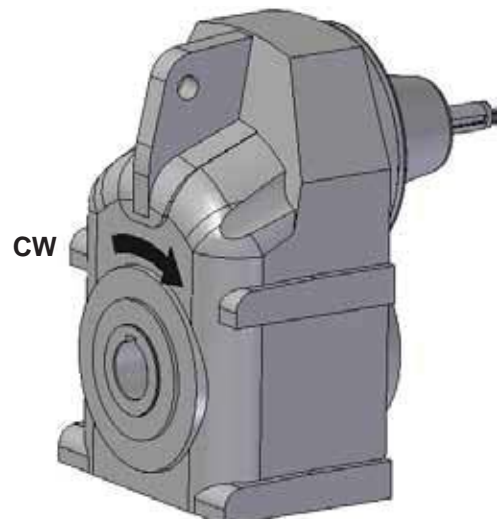

Advantages with Kibo taper bushes

- Simple design
- Easy to mount
- Easy to dismount, built in puller
- Tapered bushes assure a safe mounting
- Reduces risk for shearing of key
- Bushings for different bore dimensions are available

The Kibo bush kit comprises of: bushes, locking nuts, end plate, fastening bolt, shaft key and protective cover.

Mounting

For correct mounting of speed reducer it is important that both bushings get the same squeezing force.

1. Mount the inner bushing with the nut in its outer position. The bushing should be mounted against the shoulder or circlip. The shoulder should not exceed inside diameter of nut.
2. Fit the key in the keyway.
3. Mount the reducer on the machine-shaft and press it against the inner bushing
4. Mount the outer bushing with the nut in it's inner position. Check that the bushing is not squeezed but the nut is in contact with the shaft sleeve.
5. Mount the end plate with its fixing bolt. Tighten the bolt with correct torque. The inner bushing is now locked.
6. Loosen the bolt, so the outer bushing is loose. Turn the nut on the bushing, in it's outer position.
7. Tighten the bolt once again with correct torque. The outer bushing is now locked.
The thicker end plate may be changed to the thinner one in order to gain more space at the hollow shaft end. The thinner end plate should be tightened with a torque of 25% of the value given in the table below.
8. Screw the nuts against the hollow shaft by hand, mounting is completed.
9. Fit protective cover.

Dismounting

- Loosen the bolt and take away the end plate.
- Pull out the outer bushing with the nut, by turning the nut with an adequate tool. Take out the bushing.
- Press the reducer from the inner bushing with the nut, dismounting is completed.

NOTE:

If reducer is mounted in a corrosive environment, ensure machine shaft bushings and nuts are oiled or greased.
Do NOT use grease based on molybdenisulfide.

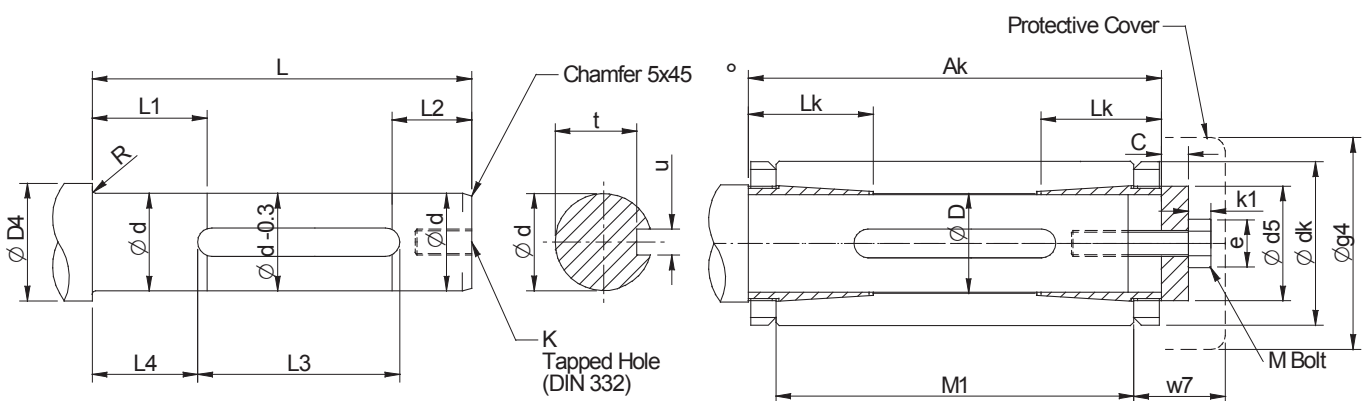

SERIES F

KIBO BUSHES

Unit Size	Customers Shaft											
	φd (h8)	φD4		K Din(332)	L	L1	L2	L3	L4	R (max)	t	u (N9)
		min	max									
F04	35	40	42	M12x28	175	40	36	60	60	1.2	30	10
	30	35		M10x22							26	8
	25	30		M10x22							21	8
F05	40	45	51	M16x36	198	50	42	77	65	1.2	35	12
	35	40		M12x28							30	10
	30	35		M10x22							26	8
F06	40	45	51	M16x36	225	50	45	77	78	1.2	35	12
	35	40		M12x28							30	10
	30	35		M10x22							26	8
F07	50	55	61	M16x36	258	58	52	79	93	1.2	44.5	14
	45	50									39.5	14
	40	45									35	12
F08	60	66	71	M20x42	293	61	52	108	97.5	1.6	53	18
	55	61		M16x36							49	16
	50	56		M16x36							44.5	14
F09	70	76	81	M20x42	340	70	50	131	75	1.6	62.5	20
	65	71									58	18
	60	66									53	18
F10	80	88	96	M20x42	390	70	60	141	115	1.6	71	22
	75	83									67.5	20
	70	78									62.5	20
F11	90	99	101	M24x50	368	70	73	181	110	2	81	25
	85	94									76	22
	80	89									71	22
F12	100	109	116	M24x50	428	80	83	200	111	2.5	90	28
	95	104									86	25
	90	99									81	25

Unit Size	Customers Shaft							End Plate						Cover	
	φD	KIBO Bush Kit	Column 11 entry	φdk	m1	Ak	Lk	φd5	C	Fixing Bolt			Tightening Torque Nm	φg4	w7
										M	e	k1			
F04	35	C38214-S1	1	65	156.5	180	40	45	10	M12	22	8	56	78	34
	30	C38214-S3	2							M10	20	7	40		
	25	C38214-S4	3												
F05	40	C38364-S2	1	75	179	207	50	55	12	M16	28	10	124	80	41
	35	C38364-S3	2							M12	22	8	70		
	30	C38364-S4	3							M10	20	7	40		
F06	40	C38364-S2	1	75	205	233	50	55	12	M16	28	10	124	80	41
	35	C38364-S3	2							M12	22	8	70		
	30	C38364-S4	3							M10	20	7	40		
F07	50	C38464-S9	1	80	233.6	264.5	58	65	14	M16	28	10	154	118	42
	45	C38464-S10	2												
	40	C38464-S11	3												
F08	60	C38614-S1	1	98	270	303	61	75	16	M20	35	13	240	142	51
	55	C38614-S2	2							M16	28	10	169		
	50	C38614-S3	3												
F09	70	C38684-S1	1	110	330	369	67.5	85	20	M20	35	13	290	154	65
	65	C38684-S2	2												
	60	C38684-S3	3												
F10	80	B93404-S1	1	125	370	410	52	95	22	M20	35	13	274	154	65
	75	B93404-S2	2												
	70	B93404-S3	3												
F11	90	B91884-S1	1	140		390	57	105	26	M24	42	15	290		
	85	B91884-S2	2												
	80	B91884-S3	3												
F12	100	C38834-S1	1	155		450	83	130	7	M24	42	15	451		
	95	C38834-S2	2												
	90	C38834-S3	3												

SERIES F

TORQUE BUSH

RUBBER BUFFERS FOR TORQUE ARM

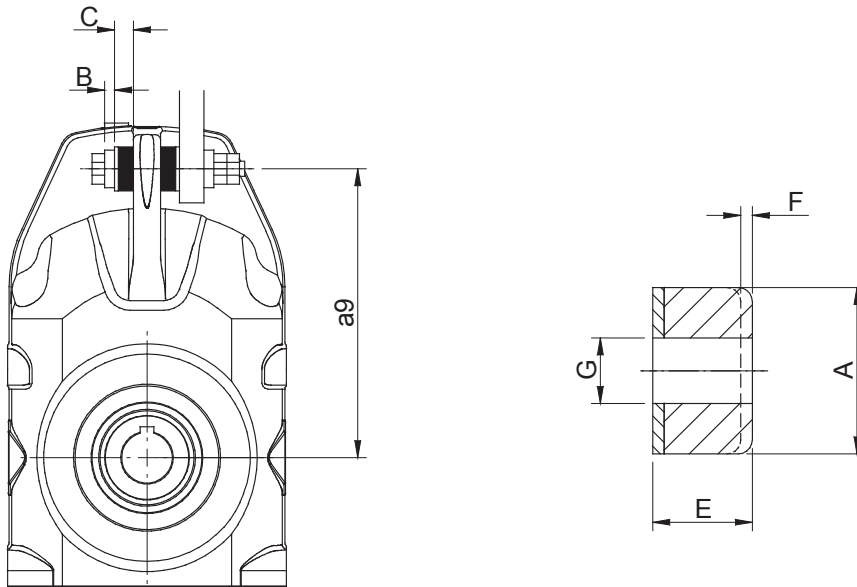

UNIT SIZE	A	B (min thickness)	C	a9	E	F	G
F02	40	2	18.5	140	20	1.5	13
F03	40	2	18	158	20	2	13
F04	40	2	18	170	20	2	13
F05	40	2	18	198	20	2	13
F06	40	2	18	218	20	2	13
F07	62	10	30	278	33	3	23
F08	62	10	29	346	33	4	23
F09	82	12	40	395	44	4	26
F10	82	12	38	485	44	5	26
F11	82	12	38	485	44	6	26
F12	102	12	48	550	54	6	33

SERIES F

DIMENSIONS

D (B5) FLANGE

Column 9 Entry

F B5 (D) Output Flange

Column 11 Entry

C with Metric Shaft

H without Shaft

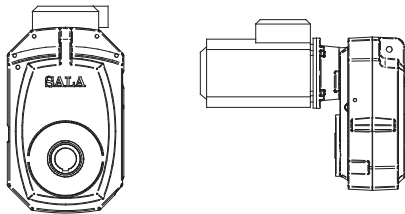
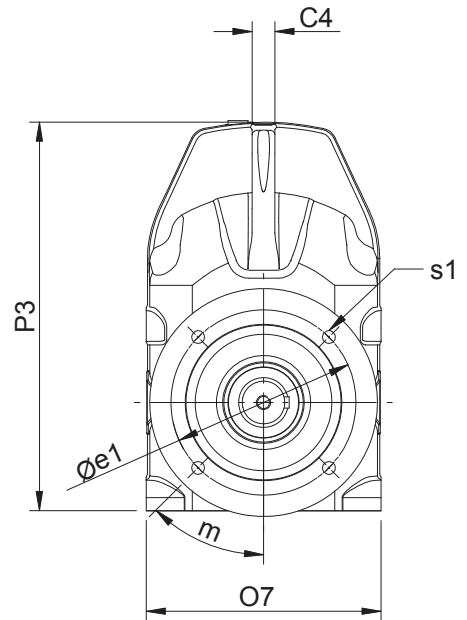
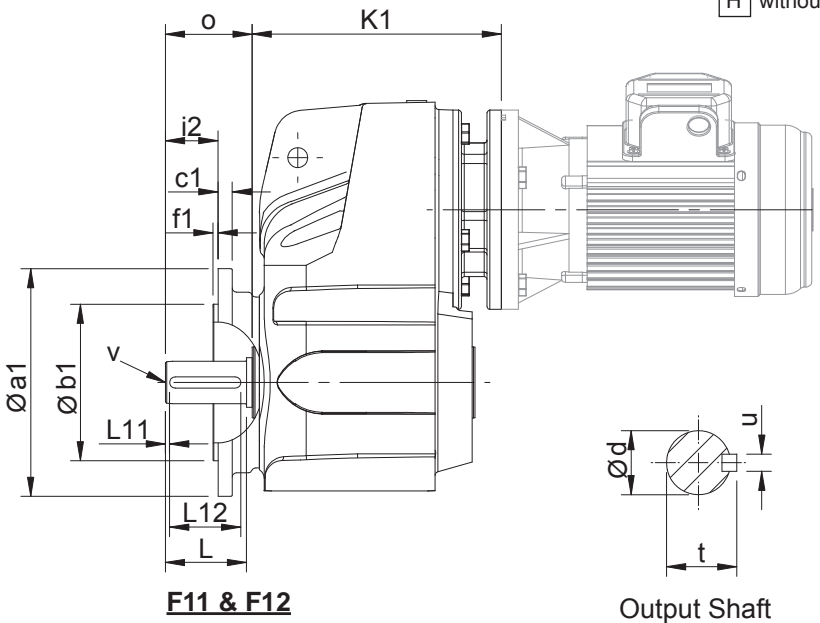

Please Note: The appearance of the F11 & F12 units is different to the other units. See pictures above.

UNIT SIZE	a1	b1	c1	C4	e1	f1	K1	m	o	O7	P3	s1	Output Shaft							
													d	i2	L	L11	L12	t	u	v
F02	160	110 j6	10	15	130	3.5	See Motorised or Reducer Dimension Pages	45	-	150	224	4 x 9	-	-	-	-	-	-	-	
F03	160	110 j6	10	16	130	3.5		45	50	171	273	4 x 9	25	26	47	3	40	28	8	M10x22
F04	160	110 j6	10	16	130	3.5		45	60	171	273	4 x 9	30	36	56	3	50	33	8	M12x28
F05	250	180 j6	16	16	215	4		45	70	206	318	4 x 14	35	44	66	3	60	38	10	M16x36
F06	250	180 j6	18	16	215	4		45	81	231	365	4 x 14	40	40	76	3	70	43	12	M16x36
F07	300	230 j6	18	20	265	4		45	101	282	442	4 x 14	50	61	95	3	80	53.5	14	M16x36
F08	350	250 h6	18	26	300	5		45	120	346	536	4 x 18	60	73	114	3	100	64	18	M20x42
F09	450	350 h6	20	30	400	5		22.5	141	400	612	8 x 18	70	90	135	3	110	74.5	20	M20x42
F10	450	350 h6	22	36	400	5		22.5	172	470	748	8 x 18	90	112	172	5	140	95	25	M20x42
F11	552	450 h6	20	40	500	5		22.5	137	498	784	8 x 18	90	170	141	14	141	95	25	M24x50
F12	650	550 h6	25	50	600	5		22.5	151	550	877	8 x 22	110	210	160	25	160	116	28	M24x50

SERIES F

DIMENSIONS

C (B14) FLANGE

Column 9 Entry

T or W B14 (C) Flange (see page 2 for further details)

Column 11 Entry

C with Metric Shaft

H without Shaft

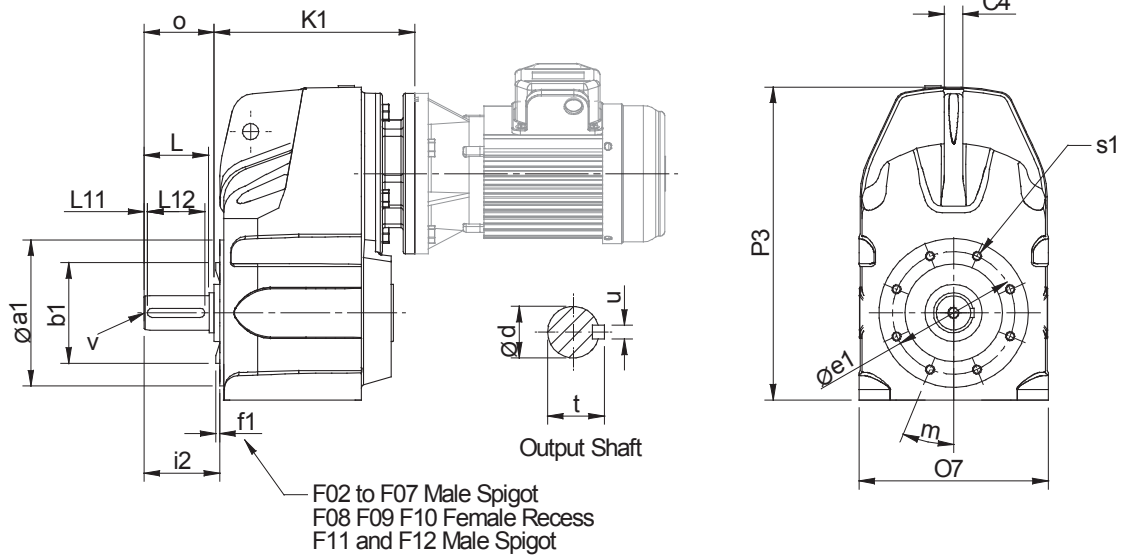

F11 & F12

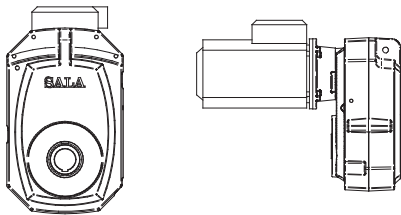

Please Note: The appearance of the F11 & F12 units is different to the other units. See pictures above.

UNIT SIZE	a1	b1	C4	e1	f1 Male	F1 Female	K1	m	o	O7	P3	s1	Output Shaft							
													d	i2	L	L11	L12	t	u	v
F02	117	85 j6	15	107	3	-	See Motorised or Reducer Dimension Pages	67.5	-	150	224	4 - M8x12	-	-	-	-	-	-	-	
F03	122	85 j6	16	107	3	-		22.5	50	171	273	4 - M8x12	25	55	47	3	40	28	8	M10x22
F04	122	85 j6	16	107	3	-		22.5	60	171	273	4 - M8x12	30	65	56	3	50	33	8	M12x28
F05	145	105 j6	16	125	3	-		30	70	206	318	6 - M10x17	35	75	66	3	60	38	10	M16x36
F06	181	130 j6	16	150	4	-		0	81	231	365	8 - M10x20	40	87	76	3	70	43	12	M16x36
F07	181	130 j6	20	150	4	-		0	101	282	442	8 - M10x20	50	108	95	3	80	53.5	14	M16x36
F08	227	150 H7	26	195	-	- 5		22.5	120	346	536	8 - M12x20	60	123	114	3	100	64	18	M20x42
F09	280	180 H7	30	230	-	- 6		0	141	400	612	6 - M16x27	70	146	135	3	110	74.5	20	M20x42
F10	310	210 H7	36	280	-	- 7		0	172	470	748	10 - M16x27	90	177.5	172	5	140	95	25	M20x42
F11	320	230 J7	40	265	5	-		0	208	498	784	8 - M20x35	90	498	170	14	141	95	25	M24
F12	350	250 J7	50	300	5	-		22.5	253	550	877	8 - M20x35	110	550	210	25	160	116	28	M24

SERIES F

DIMENSIONS STANDARD BORE ASSEMBLY

ASSEMBLY ONTO SHAFT - CUSTOMERS SHAFT DETAIL

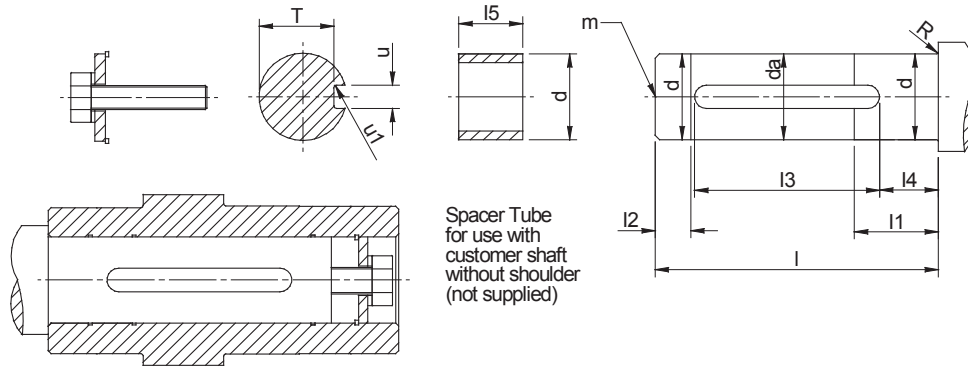

Size	d	da	l	l1	l2	l3	l4	l5	m	N	R	T	u	u1
F02	24.993 / 24.980	24.6	82	40	13	70	3	23	M10 x 1.5 22 deep	15 Nm	0.8R	21 20.8	8.000 / 7.964	0.16 0.25R
F03	29.993 / 29.980	29.6	82	45	15	70	3	23	M10 x 1.5 22 deep	15 Nm	0.8R	26 25.8	8.000 / 7.964	0.16 0.25R
F04	34.991 / 34.975	34.6	109	60	20	90	3	23	M12 x 1.75 30 deep	20 Nm	0.8R	30 29.8	10.000 / 9.964	0.16 0.25R
F05	39.991 / 39.975	39.6	112	60	20	92	3	30	M16 x 2 38 deep	45 Nm	0.8R	35 34.8	12.000 / 11.957	0.4 0.25R
F06	39.991 / 39.975	39.6	126	75	25	100	3	30	M16 x 2 38 deep	45 Nm	0.8R	35 34.8	12.000 / 11.957	0.4 0.25R
F07	49.991 / 49.975	49.6	153	90	30	130	3	30	M16 x 2 38 deep	45 Nm	0.8R	44.5 44.3	14.000 / 13.957	0.4 0.25R
F08	59.990 / 59.971	59.6	173	90	30	148	3	37	M20 x 2.5 42 deep	85 Nm	0.8R	53 52.8	18.000 / 17.957	0.4 0.25R
F09	69.990 / 69.971	69.6	232	105	35	161	3	38	M20 x 2.5P 42 deep	85 Nm	0.8R	62.5 62.3	20.000 / 19.948	0.6 0.4R
F10	79.990 / 79.971	79.6	275	120	40	188	5	37	M20 x 2.5P 42 deep	85 Nm	0.8R	71 70.8	22.000 / 21.948	0.6 0.4R
F11	89.988 / 89.966	99.6	327	150	277	206	10	-	M24 x 3 50 deep	200 Nm	0.8R	90 89.8	28.000 / 27.948	0.6 0.4R
F12	99.988 / 99.966	99.6	327	150	277	228	10	-	M24 x 3 50 deep	200 Nm	0.8R	90 89.8	28.000 / 27.948	0.6 0.4R

Assembly Instructions

1. Spray the hollow shaft bore and mating diameter of the output shaft with Rocol DFSM or equivalent anti-scuffing spray.
2. Fit key into shaft.
3. Fit the circlip into the output sleeve. (except F11 & F12 units)
4. Fit the spacer tube only if the output shaft has no shoulder, then fit the output shaft into the output sleeve. (except F11 & F12 units)
5. Secure in place with the washer and bolt. Torque tighten to the values stated in column N of the above table.
6. Fit protective cover.

SERIES F

DIMENSIONS STANDARD BORE DISASSEMBLY

DISASSEMBLY METHOD FROM SHAFT

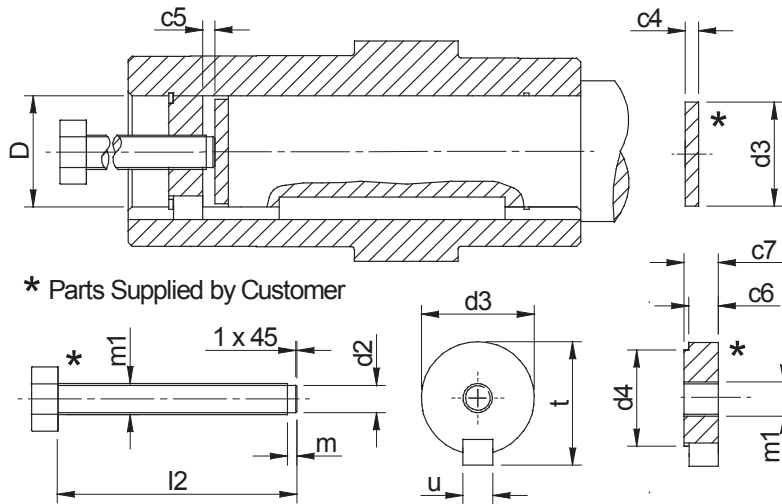

Size	c4	c5	c6	c7	D	d2	d3	d4	l2	m	m1	t	u
F02	5	3	15	17	25	10	24.9	16	120	3	M12 x 1.75	28	8
F03	5	3	15	17	30	13	29.9	20.8	130	3	M16 x 2	33	8
F04	5	3	15	17	35	13	34.9	25.2	160	3	M16 x 2	38	10
F05	5	4	20	23	40	20	39.9	29.9	190	3	M24 x 3	43	12
F06	5	4	20	23	40	20	39.9	29.9	190	3	M24 x 3	43	12
F07	5	4	20	23	50	20	49.9	39	220	3	M24 x 3	53.5	14
F08	8	5	24	27	60	26	59.9	47.4	250	5	M30 x 3.5	64	18
F09	8	6	24	27	70	26	69.9	56.4	310	5	M30 x 3.5	74.5	20
F10	8	6	24	27	80	26	79.9	65.5	360	5	M30 x 3.5	95	22
F11	-	-	-	-	-	-	-	-	-	-	-	-	-
F12	-	-	-	-	-	-	-	-	-	-	-	-	-

SERIES F

SHIPPING SPECIFICATION

UNIT SIZE & No OF REDUCTIONS		F0222	F0232	F0322	F0332	F0342	F0422	F0432	F0442	F0522	F0532	F0542	
REDUCER VERSION		13	14	20	21	30	21	22	31	31	31	44	
OUTPUT SHAFT		N/A	N/A	0.8	0.8	0.8	1.2	1.2	1.2	1.4	1.4	1.4	
OUTPUT FLANGE		1.4	1.4	1.4	1.4	1.4	1.4	1.4	1.4	4.2	4.2	4.2	
MOTORISED	63	Without Motor	12	13	19	20	29	19	20	29	27	28	40
		With Motor	17	18	24	25	34	24	25	34	32	33	45
	71	Without Motor	11	12	19	20	29	19	20	29	27	28	39
		With Motor	18	19	26	27	36	26	27	36	34	35	46
	80A	Without Motor	12	13	19	20	29	19	20	29	27	28	39
		With Motor	22	23	29	30	39	29	30	39	37	38	49
	80B	Without Motor	12	13	19	20	29	19	20	29	27	28	39
		With Motor	23	24	30	31	40	30	31	40	38	39	50
	90S	Without Motor	12	13	20	21	30	20	21	30	28	29	40
		With Motor	26	27	34	35	44	34	35	44	42	43	54
	90L	Without Motor	12	13	20	21	30	20	21	30	28	29	40
		With Motor	28	29	36	37	46	36	37	46	44	45	56
	100L	Without Motor			23			23			31		
		With Motor			48			48			56		
	112M	Without Motor			23			23			31		
		With Motor			54			54			62		
	132S	Without Motor									32		
		With Motor									72		
	132M	Without Motor									32		
		With Motor									120		
	160M	Without Motor											
		With Motor											
	160L	Without Motor											
		With Motor											
	180M	Without Motor											
		With Motor											
	180L	Without Motor											
		With Motor											
	200L	Without Motor											
		With Motor											
	225S	Without Motor											
		With Motor											
	225M	Without Motor											
		With Motor											
	250M	Without Motor											
		With Motor											
280S	Without Motor												
	With Motor												
280M	Without Motor												
	With Motor												

SERIES F

SHIPPING SPECIFICATION

UNIT SIZE & No OF REDUCTIONS		F0622	F0632	F0642	F0722	F0732	F0742	F0822	F0832	F0842	F0921	F0931	F0941	
REDUCER VERSION		45	45	56	70	77	117	115	121	134	171	180	218	
OUTPUT SHAFT		1.9	1.9	1.9	3.7	3.7	3.7	7	7	7	11	11	11	
OUTPUT FLANGE		5.6	5.6	5.6	7.2	7.2	7.2	13	13	13	15	15	15	
MOTORISED	63	Without Motor	42	43	54			74			133			
		With Motor	47	48	59			79			138			
	71	Without Motor	42	43	54			74			133			
		With Motor	49	50	61			81			140			
	80A	Without Motor	42	43	54	63	68	74	114	116	133	174	184	218
		With Motor	52	53	64	73	78	84	124	126	143	184	194	228
	80B	Without Motor	42	43	54	63	68	74	114	116	133	174	184	218
		With Motor	53	54	65	74	79	85	125	127	144	185	195	229
	90S	Without Motor	42	43	55	64	69	75	114	116	134	174	184	218
		With Motor	56	57	69	78	83	89	128	130	148	188	198	232
	90L	Without Motor	42	43	55	64	69	75	114	116	134	174	184	218
		With Motor	58	59	71	80	85	91	130	132	150	190	200	234
	100L	Without Motor	45	43		65	70		116	118		174	184	224
		With Motor	70	68		90	95		141	143		199	209	249
	112M	Without Motor	45	46		65	70		116	118		174	184	224
		With Motor	76	77		96	101		147	149		205	211	255
	132S	Without Motor	46			65	70		119	121		174		225
		With Motor	86			105	110		159	161		214		265
	132M	Without Motor	46			65	70		119	121		174		225
		With Motor	134			153	158		207	209		262		313
	160M	Without Motor				65			119	121		181		229
		With Motor				146			200	202		262		310
	160L	Without Motor				65			119	121		181		229
		With Motor				168			222	224		284		332
	180M	Without Motor										181		
		With Motor										348		
	180L	Without Motor										181		
		With Motor										362		
	200L	Without Motor										195		
		With Motor										427		
	225S	Without Motor										195		
		With Motor										482		
	225M	Without Motor										195		
		With Motor										517		
	250M	Without Motor												
		With Motor												
	280S	Without Motor												
		With Motor												
	280M	Without Motor												
		With Motor												

SERIES F

SHIPPING SPECIFICATION

UNIT SIZE & No OF REDUCTIONS		F1021	F1031	F1041	F1121	F1131	F1221	F1231	
REDUCER VERSION		261	270	332	N/A	N/A	N/A	N/A	
OUTPUT SHAFT		18.5	18.5	18.5	25	25	40	40	
OUTPUT FLANGE		26	26	26	20	20	30	30	
MOTORISED	63	Without Motor							
		With Motor							
	71	Without Motor							
		With Motor							
	80A	Without Motor		273	325				
		With Motor		283	335				
	80B	Without Motor		273	325				
		With Motor		284	336				
	90S	Without Motor		273	326				
		With Motor		287	340				
	90L	Without Motor		273	326				
		With Motor		289	342				
	100L	Without Motor	254	273	328		320		
		With Motor	279	298	353		345		
	112M	Without Motor	254	273	328		320		
		With Motor	285	304	359		351		
	132S	Without Motor	254	273	332		320	506	
		With Motor	294	313	372		360	546	
	132M	Without Motor	254	273	332		320	506	
		With Motor	342	361	420		408	594	
	160M	Without Motor	263	280	333	345	332	500	495
		With Motor	344	361	414	426	413	581	576
	160L	Without Motor	263	280	333	645	332	500	495
		With Motor	366	383	436	448	435	603	598
	180M	Without Motor	263	280		345	332	500	495
		With Motor	430	447		512	499	667	662
	180L	Without Motor	263	280		345	332	500	495
		With Motor	444	461		526	499	681	676
	200L	Without Motor	263	281		345		500	506
		With Motor	495	513		577		732	738
	225S	Without Motor	277	295		359		514	509
		With Motor	564	582		646		801	796
	225M	Without Motor	277	295		359		514	509
		With Motor	599	617		681		836	831
	250M	Without Motor				375		530	
		With Motor				825		980	
	280S	Without Motor						530	
		With Motor						1090	
	280M	Without Motor						530	
		With Motor						1130	

IMPORTANT

Product Safety Information

General - The following information is important in ensuring safety. It **must** be brought to the attention of personnel involved in the selection of the equipment, those responsible for the design of the machinery in which it is to be incorporated and those involved in its installation, use and maintenance.

The equipment will operate safely provided it is selected, installed, used and maintained properly. As with any power transmission equipment **proper precautions must** be taken as indicated in the following paragraphs, to ensure safety.

Potential Hazards - these are **not** necessarily listed in any order of severity as the degree of danger varies in individual circumstances. It is important therefore that the list is studied in its entirety:-

- 1) Fire/Explosion
 - (a) Oil mists and vapour are generated within gear units. It is therefore dangerous to use naked lights in the proximity of gearbox openings, due to the risk of fire or explosion.
 - (b) In the event of fire or serious overheating (over 300 °C), certain materials (rubber, plastics, etc.) may decompose and produce fumes. Care should be taken to avoid exposure to the fumes, and the remains of burned or overheated plastic/rubber materials should be handled with rubber gloves.
- 2) Guards - Rotating shafts and couplings must be guarded to eliminate the possibility of physical contact or entanglement of clothing. It should be of rigid construction and firmly secured.
- 3) Noise - High speed gearboxes and gearbox driven machinery may produce noise levels which are damaging to the hearing with prolonged exposure. Ear defenders should be provided for personnel in these circumstances. Reference should be made to the Department of Employment Code of Practice for reducing exposure of employed persons to noise.
- 4) Lifting - Where provided (on larger units) only the lifting points or eyebolts must be used for lifting operations (see maintenance manual or general arrangement drawing for lifting point positions). Failure to use the lifting points provided may result in personal injury and/or damage to the product or surrounding equipment. Keep clear of raised equipment.
- 5) Lubricants and Lubrication
 - (a) Prolonged contact with lubricants can be detrimental to the skin. The manufacturer's instruction must be followed when handling lubricants.
 - (b) The lubrication status of the equipment must be checked before commissioning. Read and carry out all instructions on the lubricant plate and in the installation and maintenance literature. Heed all warning tags. Failure to do so could result in mechanical damage and in extreme cases risk of injury to personnel.
- 6) Electrical Equipment - Observe hazard warnings on electrical equipment and isolate power before working on the gearbox or associated equipment, in order to prevent the machinery being started.
- 7) Installation, Maintenance and Storage
 - (a) In the event that equipment is to be held in storage, for a period exceeding 6 months, prior to installation or commissioning, application engineering must be consulted regarding special preservation requirements. Unless otherwise agreed, equipment must be stored in a building protected from extremes of temperature and humidity to prevent deterioration.
The rotating components (gears and shafts) must be turned a few revolutions once a month (to prevent bearings brinelling).
 - (b) External gearbox components may be supplied with preservative materials applied, in the form of a "waxed" tape overwrap or wax film preservative. Gloves should be worn when removing these materials. The former can be removed manually, the latter using white spirit as a solvent.

Preservatives applied to the internal parts of the gear units do not require removal prior to operation.
 - (c) Installation must be performed in accordance with the manufacturer's instructions and be undertaken by suitably qualified personnel.
 - (d) Before working on a gearbox or associated equipment, ensure that the load has been removed from the system to eliminate the possibility of any movement of the machinery and isolate power supply. Where necessary, provide mechanical means to ensure the machinery cannot move or rotate. Ensure removal of such devices after work is complete.
 - (e) Ensure the proper maintenance of gearboxes in operation. Use only the correct tools and approved spare parts for repair and maintenance. Consult the Maintenance Manual before dismantling or performing maintenance work.
- 8) Hot Surfaces and Lubricants
 - (a) During operation, gear units may become sufficiently hot to cause skin burns. Care must be taken to avoid accidental contact.
 - (b) After extended running the lubricant in gear units and lubrication systems may reach temperatures sufficient to cause burns. Allow equipment to cool before servicing or performing adjustments.
- 9) Selection and Design
 - (a) Where gear units provide a backstop facility, ensure that back-up systems are provided if failure of the backstop device would endanger personnel or result in damage.
 - (b) The driving and driven equipment must be correctly selected to ensure that the complete machinery installation will perform satisfactorily, avoiding system critical speeds, system torsional vibration, etc.
 - (c) The equipment must not be operated in an environment or at speeds, powers, torques or with external loads beyond those for which it was designed.
 - (d) As improvements in design are being made continually the contents of this catalogue are not to be regarded as binding in detail, and drawings and capacities are subject to alterations without notice.

The above guidance is based on the current state of knowledge and our best assessment of the potential hazards in the operation of the gear units.

Any further information or clarification required may be obtained by contacting an Application Engineer.

