

Series P Planetary



Technical
Up to - 90kW / 6500Nm

Planetary
CP-2.00GB0316

PRODUCTS IN THE RANGE

Serving an entire spectrum of mechanical drive applications from food, energy, mining and metal; to automotive, aerospace and marine propulsion, we are here to make a positive difference to the supply of drive solutions.

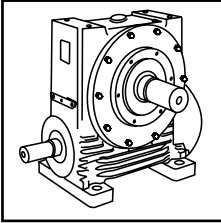

Series A
Worm Gear units
and geared motors
in single & double
reduction types

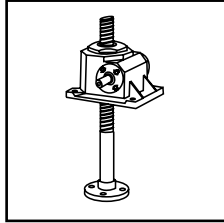

Series BD
Screwjack worm
gear unit

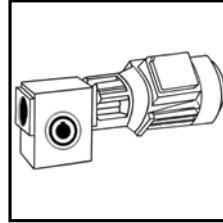

Series BS
Worm gear unit

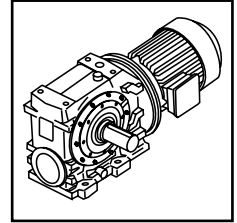

Series C
Right angle drive
helical worm geared
motors & reducers

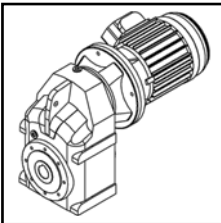

Series F
Parallel shaft helical
geared motors &
reducers

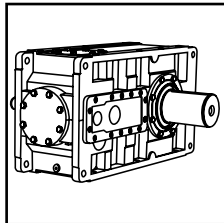

Series G
Helical parallel shaft
& bevel helical right
angle drive gear
units

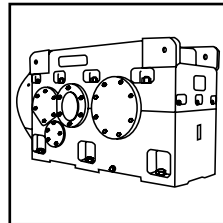

Series H
Large helical parallel
shaft & bevel helical
right angle drive units

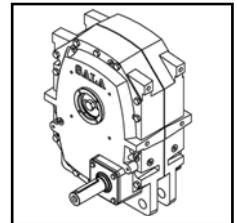

Series J
Shaft mounted
helical speed
reducers

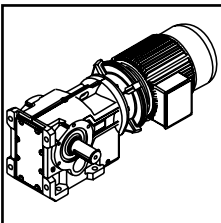

Series K
Right angle helical
bevel helical geared
motors & reducers

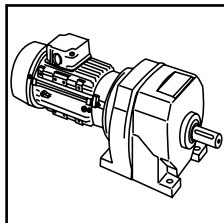

Series M
In-line helical geared
motors & reducers

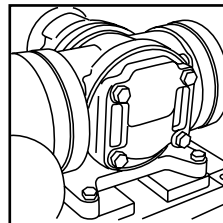

Roloid Gear Pump
Lubrication and fluid
transportation pump

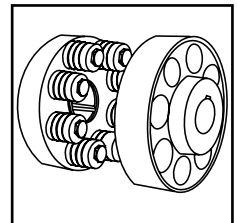

**Series X
Cone Ring**
Pin and bush
elastomer coupling

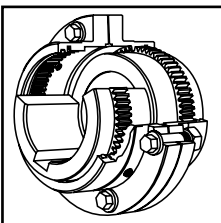

**Series X
Gear**
Torsionally rigid,
high torque coupling

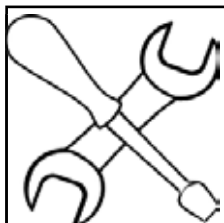

**Service &
Repair**
All brands and types

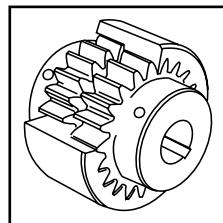

**Series X
Nylonicon**
Gear coupling with
nylon sleeve

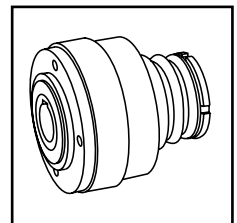

**Series X
Torque Limiter**
Overload protection
device



We offer a wide range of repair services and many years experience of repairing demanding and highly critical transmissions in numerous industries.

We can create custom engineered transmission solutions of any size and configuration.

ATEX Compliance Assured



Total compliance with the ATEX Directive safeguarding the use of industrial equipment in potentially explosive atmospheres is assured for users of our geared products.

Certification is available for standard gearboxes and geared motors with badging displaying the CE Mark and the Ex mark, name and location of the manufacturer, designation of series or type, serial number, year of manufacture, Ex symbol and equipment group/category.

ATEX directive 94/9/EC (also known as ATEX 95 or ATEX 100A) and the CE Marking Directive are enforced in all EC member states. Compliance is compulsory for designers, manufacturers or suppliers of electrical and non-electrical equipment for use in potentially explosive atmospheres created by the presence of flammable gases, vapours, mists or dusts.

Ex compliant standard gearboxes can be supplied against Groups 2 or 3 for surface industries in designated hazardous location Zones 1 and 2 for gases, vapours and mists; and in Zones 21 and 22 for dusts.

SERIES P

NOTES

SERIES P

CONTENTS

General Description _____	2
Selection _____	3 - 6
Designation _____	7
Nominal Torque _____	8 - 9
Overhung Loads _____	10 - 11
PL01 Ratings / Dimensions _____	14
PL02 Ratings / Dimensions _____	16
PL03 Ratings / Dimensions _____	18
PL05 Ratings / Dimensions _____	20
PL08 Ratings / Dimensions _____	22
PL12 Ratings / Dimensions _____	24
PL16 Ratings / Dimensions _____	26
PL25 Ratings / Dimensions _____	28
PL40 Ratings / Dimensions _____	30
PL65 Ratings / Dimensions _____	32
Motorised Ratings PL units _____	34 - 54
PR01 Ratings / Dimensions _____	56
PR02 Ratings / Dimensions _____	58
PR03 Ratings / Dimensions _____	60
PR05 Ratings / Dimensions _____	62
PR08 Ratings / Dimensions _____	64
PR12 Ratings / Dimensions _____	66
PR16 Ratings / Dimensions _____	68
PR25 Ratings / Dimensions _____	70
PR40 Ratings / Dimensions _____	72
PR65 Ratings / Dimensions _____	74
Motorised Ratings PR units _____	76 - 89
Lubrication _____	90 - 92
Shipping Specification _____	93 - 94

GENERAL DESCRIPTION

The range of Series P Planetary units has 10 sizes with ratio coverage from 3.6:1 to 3200:1 providing an efficient and compact drive solution to meet power requirements up to 90kW and 65000 Nm torque capacity.

The range takes advantage of many years of accumulated design expertise, together with the use of high quality materials and components, the end result is a high quality series of planetary gear reducers and geared motors offering a high load carrying capacity, high efficiency, quiet running and reliable drive solution.

Standard unit versions available:

Parallel (co-axial) and Right Angle drive options:

- Base Mounted
- Flange Mounted

Input options:

- Input shaft with keyway
- Motor adapter to suit fitting of IEC B5 motor
- Motor adapter to suit fitting of NEMA C flange motor
- Motor adapter to suit Hydraulic or Servo Motor's

Output options:

- Output shaft with keyway
- Hollow output shaft to suit connection with shrink disc
- Output shaft with external spline
- Output shaft with internal spline

Design features:

- Gears are manufactured from high quality materials heat treated and profile ground providing a high level of surface finish to ensure efficient high load carrying capacity and quiet operation
- Motor connections are designed to suit standard IEC or NEMA C motors, other motor connections can be provided on request.
- All units are designed with ability to fit double oil seals to both input and output shaft assemblies
- Units are designed to be dimensionally interchangeable with other major manufacturers
- Units are modular in design allowing many possible unit combinations to be built from a limited inventory
- Units are designed so that they may be easily customised to suit more exacting customer requirements.



GEAR UNIT SELECTION

f	Service Factor ($f = f_m \times f_s$)	f_m	Mechanical Service Factor
Fr1	Input Shaft Radial Load Capacity (N)	Fr2	Output Shaft Radial Load Capacity (N)
f_s	Starting Frequency Factor		
n1	Input Speed (rpm)	n2	Output Speed (rpm)
i	Actual Transmission Ratio = $\frac{n1}{n2}$	i_N	Nominal Transmission Ratio
Pe	Absorbed Power (kW)	T2	Rated Output Torque (Nm)
M2	Output Torque (Nm) = $\frac{Pe \times 9550}{n2}$	T2a	Required Rated Torque (Nm) = $M2 \times f$
n2*h	Output Speed (rpm) x Operating Hours	h	Lifetime (hours)
Pt	Thermal Rating (when $t = 20^\circ\text{C}$)	fw	Thermal Rating Modifying Factor
t	Ambient Temperature ($^\circ\text{C}$)		

Mechanical Service Factor **f_m**

Prime Mover	Operating Duty Hours/Day	Load Classification Driven Machine		
		U Uniform	M Moderate	H Heavy
Electric Motor Hydraulic Motor	< 3	0.80	1.00	1.50
	3 to 10	1.00	1.25	1.75
	>10	1.25	1.50	2.00
Piston Engine >3 Cylinders	< 3	1.00	1.25	1.75
	3 to 10	1.25	1.50	2.00
	>10	1.50	1.75	2.25
Piston Engine 1-3 Cylinders	< 3	1.25	1.50	2.00
	3 to 10	1.50	1.75	2.25
	>10	1.75	2.00	2.50

Starting Frequency Factor **f_s**

Starts (or Stops) per Hour	f_s
1	1.00
2 - 5	1.06
6 - 10	1.10
11 - 40	1.16
41 - 80	1.20
>80	1.25

Thermal Modifying Factor **fw**

Ambient Temperature	Duration of Operation per Hour				
	100%	80%	60%	40%	20%
-20°C	1.50	1.61	1.78	2.06	2.65
-10°C	1.35	1.45	1.60	1.86	2.38
0°C	1.25	1.34	1.48	1.72	2.20
10°C	1.12	1.20	1.33	1.54	1.98
20°C	1.00	1.07	1.19	1.37	1.76
25°C	0.95	1.02	1.13	1.31	1.68
30°C	0.88	0.94	1.04	1.21	1.55
40°C	0.75	0.80	0.89	1.03	1.32
50°C	0.63	0.67	0.75	0.87	1.11

SERIES P

SELECTION

Load Classification by Application

Load Classification					
U Uniform Load					
M Moderate Shock Load					
H Heavy Shock Load					
† Consult our Engineers					
Agitators		Dredgers		Machine Tools	
Pure liquids	U	Conveyors	M	Bending roll	M
Liquids and solids	M	Cutter head drive	H	Punch press	H
Liquids variable density	M	Pumps	M	Notching press	H
Blowers	U	Screen Drive	H	Plate planer	H
Centrifugal	M	Stackers	M	Other machine tools	
Lobe	U	Winches	M	Main drive	M
Vane				Aux drive	U
Brewing & distilling		Elevators		Metal mills	
Bottling machinery	M	Bucket - Uniform load	U	Carriage / Main drive	M
Brew kettles	M	Bucket - Heavy load	M	Draw bench	M
Cookers	M	Bucket - Continuous	U	Dryer	M
Mash tubs	M	Centrifugal discharge	U	Flattening machine	M
Scale Hopper	M	Escalators	U	Pinch drive	M
Can filling machine	M	Freight	M	Reversing slitters	M
Crane knife	M	Gravity discharge	U	Scrubber rolls	M
Car dumper	M	Passenger Lifts	†	Table conveyors	
Car puller	M			Group drives	M
Clarifier	U	Fans		Individual drives	H
Classifier	M	Centrifugal	U	Table conveyors - reversing	M
Clay working machinery		Cooling towers		Wire draw	H
Brick press	H	Induced draft	†	Wire roll	M
Briquette machine	H	Forced draft	†	Mills	
Clay working machine	M	Fan- Large diameter induced draft	M	Cement kiln	H
Plug mill	M	Fan, light, small diameter	M	Dryer, Cooler	H
Compressors		Feeders		Kiln (other)	H
Centrifugal	U	Apron	M	Rod plain	H
Lobe	M	Belt	M	Rod wedge bar	H
Reciprocating		Disc	U	Rotary / Ball	H
Multi cylinder	M	Reciprocating	H	Tumbling barrel	H
Single cylinder	H	Screw	M	Mixers	
Conveyors-Light duty uniform load		Food Industry		Concrete	M
Apron	U	Cereal cooker	U	Cons density	U
Assembly	U	Dough mixer	M	Variable density	M
Belt	U	Meat grinder	M	Oil Industry	
Bucket	U	Meat slicer	M	Chillers	M
Chain	U	Generators - not welding	U	Oil well pump	M
Flight	U	Hammer mills	H	Filter press	M
Oven	U	Hoists		Rotary kiln	M
Screw	U	Heavy duty	H	Paper	
Conveyors-Heavy duty non-uniform load		Medium duty	M	Agitator (mixer)	M
Apron	M	Skip hoist	M	Barker (hydraulic)	M
Assembly	M	Laundry		Barker (mechanical)	H
Belt	M	Tumbler	M	Barking drum	H
Bucket	M	Washer	M	Beater & pulper	M
Chain	M	Line shafts		Bleacher	U
Flight	M	Heavy duty	M	Calenders	M
Live roll	†	Light duty	U	Calender- Super	H
Oven	M	Lumber industry		Converting machine	M
Reciprocating	M	Barkers	M	Conveyors	U
Screw	M	Burner conveyor	M	Couch	M
Shaker	M	Chain / Drag saw	H	Cutters - plates	H
Cranes	†	Chain transfer	H	Cylinders	M
Crusher		Chain way transfer	H	Dryers	M
Ore	H	De-barking drum	H	Felt stretcher	M
Stone	H	Edger feed	M	Felt whipper	H
Sugar	H	Gang feed	M	Jordans	M
		Green chain	M	Log haul	H
		Live roll	H	Machine reel	M
		Log deck	H	Presses	M
		Log Haul	H	Stock chest	M
		Log turning	H	Suction roll	M
		Log conveyor	H	Washers & thickeners	M
		Of bearing roll	M	Winders	M
		Planer feed chains	M	Printing presses	†
		Planer hoist	M	Pullers	
		Re-saw conveyor	M	Barge haul	H
		Roll cases	H	Pumps	
		Slab conveyor	H	Centrifugal	U
		Sorting table Triple hoist	M	Proportioning	M
		Triple hoist - drive/conveyor	M	Reciprocating	
		Transfer conveyor	M	Single acting 3+ cylinders	M
		Transfer roll	M	Double acting 2+ cylinders	M
		Tray drive	M	Single acting 1 & 2 cylinders	†
		Trimmer feed	M	Double acting 1 cylinder	†
		Waste conveyor	M	Rotary - gear type	U
		Small waste conveyor (belt)	U	Rotary - lobe type / vane	U
		Small waste conveyor (chain)	M		
				Sand muller	M
				Seaweed treatment	
				Bar screen	U
				Chemical feeder	U
				Collector	U
				Dewatering screw	M
				Mixers	M
				Scum breaker	M
				Thickeners	M
				Vacuum filters	M
				Screens	
				Air washing	U
				Rotary, stone or gravel	M
				Travelling water intake	U
				Slab pushers	M
				Slowing	H
				Steering gear	†
				Stokers	U
				Sugar Industry	
				Cane Knife	M
				Crusher	M
				Mills	M
				Textile Industry	
				Batchers	M
				Calenders	M
				Cards	M
				Dry cans	M
				Dryers	M
				Dyeing machinery	M
				Knitting machines	M
				Looms	M
				Mangles	M
				Nappers	M
				Pads	M
				Range drive	M
				Slashers	M
				Soapers	M
				Spinners	M
				Tenter frame	M
				Washers	M
				Winders	M
				Windlass	†

SELECTION EXAMPLE

Absorbed Power (P_e) = 4.5 kW

$n_1 = 1450$ rpm, $n_2 = 22$ rpm

Required Ratio (i) = $\frac{1450}{22} = 66:1$

Ambient Temperature (t) = 30°C

Moderate Shock Loading - 1 start / hour
8 hours / day - Continuous Operation
Expected Service Life 20,000 hours

1. Determine Service Factor - f

Refer to: Mechanical Service Factor Table f_m
Starting Frequency Factor Table f_s

Prime Mover	Operating Duty Hours/Day	Load Classification Driven Machine			Starts (or Stops) per Hour	f_s
		U Uniform	M Moderate	H Heavy		
Electric Motor Hydraulic Motor	< 3	0.80	1.00	1.50	1	1.00
	3 to 10	1.00	1.25	1.75	2 - 5	1.06
	>10	1.25	1.50	2.00	6 - 10	1.10
Piston Engine >3 Cylinders	< 3	1.00	1.25	1.75	11 - 40	1.16
	3 to 10	1.25	1.50	2.00	41 - 80	1.20
	>10	1.50	1.75	2.25		

$$f = f_m \times f_s (1.25 \times 1.00) \quad f = 1.25$$

2. Determine the Output Torque - M_2

$$M_2 = \frac{P_e \times 9550}{n_2}$$

$$M_2 = \frac{4.5 \times 9550}{22} = 1953 \text{ Nm}$$

3. Determine the Required Rated Torque - T_{2a}

$$T_{2a} = M_2 \times f$$

$$T_{2a} = 1953 \times 1.25 = 2441 \text{ Nm}$$

4. Determine the Required n_2^*h Value

$$n_2^*h = n_2(\text{rpm}) \times h (\text{hours})$$

$$N_2^*h = 22 \times 20,000 = 440,000 \text{ hours}$$

5. Select the Gear Unit

Refer to: The Selection Tables

SERIES P	Ratio i_N	Ratio i	T2 (Nm) n_2^*h rating						n1 Max	Pt (kW)	
			10 000	25,000	50k000	100k000	500,000	1,000,000		Type B	Type F
PL0330	56.	55.09	3930	3700	3648	3400	2536	2060	3500	10.2	9.8
	71.	66.79	3930	3700	3648	3400	2536	2060		10.1	9.7
	80.	80.96	3930	3700	3648	3400	2536	2060		10.0	9.7
	90.	87.83	3930	3700	3648	3400	2536	2060		10.0	9.6

Use the n_2^*h column that is both nearest and greater than the required n_2^*h value.

The required $n_2^*h = 400,000$ hours - The nearest n_2^*h column is 500,000 hours

Select the nearest gear unit with a rated torque T_2 (Nm) that is greater than the required torque T_{2a} (Nm)

Gear Unit Selection: PL0330, $i_N = 71$. $T_2 = 2536 \text{ Nm} > T_{2a} (2441 \text{ Nm})$

Check the exact ratio i (66.79:1) is within range of the required ratio

6. Determine the Thermal Modifying Factor - f_w

Refer to: Thermal Modifying Factor Table f_w

Ambient Temperature	Duration of Operation per Hour				
	100%	80%	60%	40%	20%
20°C	1.00	1.07	1.19	1.37	1.76
25°C	0.95	1.02	1.13	1.31	1.68
30°C	0.88	0.94	1.04	1.21	1.55
40°C	0.75	0.80	0.89	1.03	1.32

$$f_w = 0.88 \text{ for } 30^\circ\text{C Ambient and } 100\% \text{ Duration}$$

7. Check the Thermal Capacity

Refer to: The Selection Tables

$$P_t \times f_w > P_e (\text{absorbed power})$$

For the selected unit (PL0330 - $i_N 71$.)

$P_t = 10.1 \text{ kW}$ Base Mounted Unit (Type B)

$P_t = 9.7 \text{ kW}$ Flange Mounted Unit (Type F)

Absorbed Power $P_t \times f_w > P_e$

$$9.7 \text{ kW}(P_t) \times 0.88 > 4.5 \text{ kW} (P_e)$$

8. Check the Overhung Load Capacity

Refer to: The Overhung Load Charts

Input Shaft Fr_1 and Output Shaft Fr_2

Select the correct curve for gear unit

Obtain the maximum overhung load values Fr_1 or Fr_2

Fr_2 values assume $n_2^*h = 1,000,000$ hours

For alternate requirements adjust using factor C_o

Check the actual loading does not exceed Fr_1 or Fr_2 values

9. Confirm Gear Unit Selection

PL0330 - Flange Mounted Unit

Nominal Ratio (i_N) 71.

Actual Ratio (i) 66.8 : 1

SELECTION EXAMPLE MOTORISED UNIT

Parallel Unit Type PL

Absorbed Power (P_e) = 1.3 kW

Motor Power = 1.5 kW

$n_1 = 1450$ rpm, $n_2 = 16.0$ rpm

Required Ratio (i) = $\frac{1450}{16} = 90.6:1$

Ambient Temperature (t) = 40°C

Moderate Shock Loading - 1 start / hour

Note!

The Motorised Ratings Tables
Assume a lifetime 5,000 hours

1. Determine Service Factor - f

Refer to: Mechanical Service Factor Table f_m
Starting Frequency Factor Table f_s

Prime Mover	Operating Duty Hours/Day	Load Classification Driven Machine			Starts (or Stops) per Hour	f_s
		U Uniform	M Moderate	H Heavy		
Electric Motor Hydraulic Motor	< 3	0.80	1.00	1.50	1	1.00
	3 to 10	1.00	1.25	1.75	2 - 5	1.06
	>10	1.25	1.50	2.00	6 - 10	1.10
Piston Engine >3 Cylinders	< 3	1.00	1.25	1.75	11 - 40	1.16
	3 to 10	1.25	1.50	2.00	41 - 80	1.20
	>10	1.50	1.75	2.25		

$$f = f_m \times f_s (1.25 \times 1.00) \quad f = 1.25$$

2. Determine the Output Torque - M2

$$M_2 = \frac{P_e \times 9550}{n_2} \quad M_2 = \frac{1.3 \times 9550}{16} = 776 \text{ Nm}$$

3. Determine the Thermal Modifying Factor f_w

Refer to Thermal Modifying Factor Table f_w

Ambient Temperature	Duration of Operation per Hour				
	100%	80%	60%	40%	20%
25°C	0.95	1.02	1.13	1.31	1.68
30°C	0.88	0.94	1.04	1.21	1.55
40°C	0.75	0.80	0.89	1.03	1.32

$$f_w = 0.75 \text{ for } 40^\circ\text{C Ambient and } 100\% \text{ Duration}$$

4. Select the Gear Unit

Refer to: Motorised Selection Tables

(Select a motor power greater than the absorbed power)

	n_2	Ratio i	M2 (Nm)	f_m	Fr2 (N)	Unit Designation	Motor Frame	Pt (kW) Type B	Pt (kW) Type F
1.5 kW 4 - Pole	41.0	35.36	339	2.55	15000	PL0120 36. - M --- 1.5 A	90	8.6	7.8
	37.7	38.44	368	1.65	15000	PL0120 40. - M --- 1.5 A	90	8.5	7.7
	31.2	46.50	446	1.38	15000	PL0120 45. - M --- 1.5 A	90	8.4	7.5
	25.8	56.25	539	0.85	15000	PL0120 56. - M --- 1.5 A	90	8.2	7.4
	24.7	58.81	558	1.97	15000	PL0130 63. - M --- 1.5 A	90	6.9	6.4
	20.3	71.30	676	1.65	15000	PL0130 71. - M --- 1.5 A	90	6.9	6.3
	16.8	86.43	820	1.38	15000	PL0130 80. - M --- 1.5 A	90	6.8	6.2
	15.5	93.77	889	1.27	15000	PL0130 90. - M --- 1.5 A	90	6.8	6.2
	13.8	104.77	994	0.93	15000	PL0130 100. - M --- 1.5 A	90	6.7	6.2
	12.8	113.43	1076	1.07	15000	PL0130 112. - M --- 1.5 A	90	6.7	6.2

Unit selected: PL0130 Actual Ratio $i = 93.77:1$ $i_N = 90$

Check the Required Service Factor f (1.25) is less than f_m (1.27)

Check the Output Torque M_2 (889 Nm) is greater than the Required Output Torque (776 Nm)

Check Thermal Capacity $P_t \times f_w$ ($6.2 \times 0.75 = 4.65$ kW) is greater than the Absorbed Power P_e (1.3 kW)

Check the Output Speed, n_2 (15.5 rpm) is within range of requirement (16 rpm)

Check that any Overhung Load applied does not exceed Fr_2^* (N)

SERIES P

DESIGNATION

	1	2	3	4	5	6	7	8	9	10	11	12	13	14	15	16	17	18	19	20
e.g.	P	L	0	5	3	0	1	1	2	B	M	C	B	3	1	.	5	A	-	-

1 - 2 ...

Unit Type

- PL** Parallel (co-axial)
- PR** Right Angle

3 - 4 - 5 - 6 ...

Unit Size

- e.g. 0110
- 0530
- 1640 etc....

7 - 8 - 9 ...

Ratio (i N)

- e.g. 4.5
- 18.
- 112
- 10C etc....

13 - 14 - ...

Mounting Position

- e.g. B3
- B5 etc....

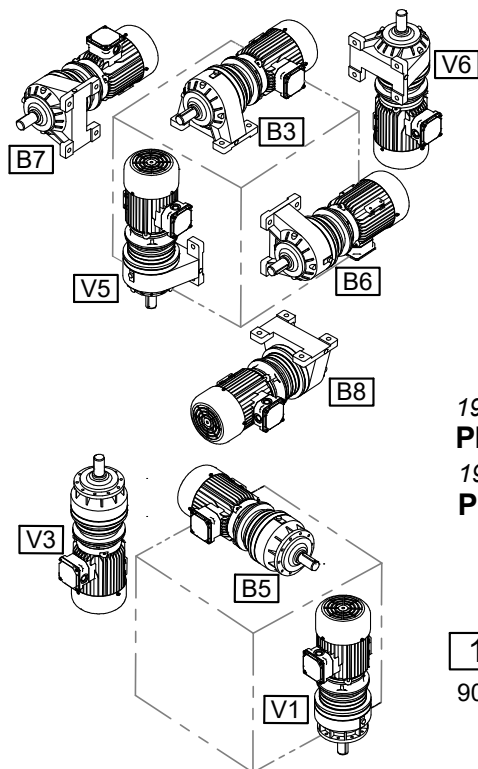

10 - 11 - 12 ...

Unit Options

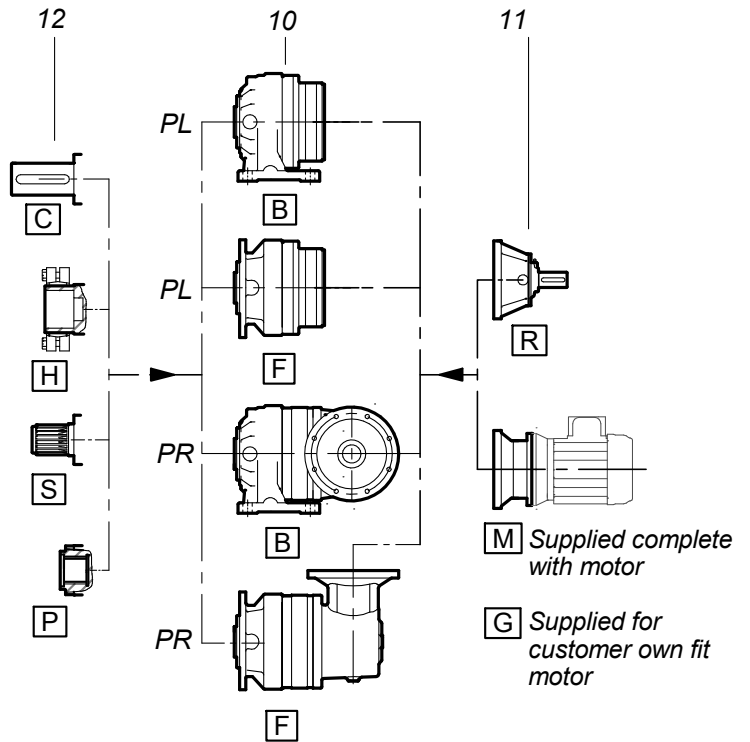

15 - 16 - 17 ...

For a motorised unit (col 11, type 'M')

Enter the **Motor Power (kW)**

e.g. .37 1.5 15. etc....

For customers own fit motor (Col 11, type 'G')

Enter the **Frame Size**

e.g. 071 080 112 etc....

For a reducer unit (col 11, type 'R') Enter ---

19 ...

PL Units enter -

19

PR Units

- standard

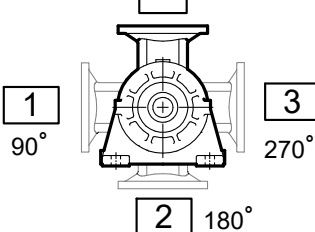

18 ...

Motor Speed

- 4 pole (1450) **A**
- 6 pole (960) **C**
- 2 pole (2900) **E**
- 8 pole (725) **G**

Supplied without motor enter -

20 ...

Additional Features

SERIES P

NOMINAL TORQUE

Parallel Units – Type PL

iN	T2 (Nm)		iN	T2 (Nm)		iN	T2 (Nm)		iN	T2 (Nm)		iN	T2 (Nm)		iN	T2 (Nm)	
	PL0110	PL0210		PL0310	PL0510		PL0810	PL1210		PL1610	PL2510		PL4010	PL6510			
3.6	1110	2050	3.6	3400	5231	3.6	9112	11277	4	16539	4	23350	4	38509	4	68250	
4.5	900	1661	4.5	2887	4442	4.5	7840	9996	5	12911	5	17657	5	28559	5	57400	
6.3	629	1162	5.6	2008	3089	5.6	5396	7196	6.3	7996	6.3	13339	6.3	23985	6.3	44680	
7.1	464	856	7.1	1494	2298	7.1	4564	6084									

iN	T2 (Nm)		iN	T2 (Nm)		iN	T2 (Nm)		iN	T2 (Nm)		iN	T2 (Nm)		iN	T2 (Nm)	
	PL0120	PL0220		PL0320	PL0520		PL0820	PL1220		PL1620	PL2520		PL4020	PL6520			
16.	1110	2050	14.	3400	5231	14.	9112	11277	14.	16539	14.	23350	16.	38509	16.	68250	
18.	1110	2050	16.	3400	5231	16.	9112	11277	16.	16539	18.	23350	20.	38509	18.	57400	
22.	900	1661	20.	2887	4442	20.	7840	9996	22.	16539	22.	23350	25.	28559	20.	68250	
25.	1110	2050	22.	3400	5231	22.	9112	11277	25.	16539	25.	23350	28.	38509	22.	57400	
28.	1110	2050	25.	3400	5231	25.	9112	11277	28.	12911	28.	17657	32.	23985	28.	68250	
36.	900	1661	32.	2887	4442	28.	7840	9996	32.	12911	32.	17657	36.	28559	32.	57400	
40.	629	1162	36.	2008	3089	32.	5396	7196	36.	7996	36.	13339	45.	23985	40.	44680	
45.	629	1162	45.	2008	3089	36.	5396	7196	45.	7996	40.	13339					
56.	464	856	50.	1494	2298	45.	4564	6084									

iN	T2 (Nm)		iN	T2 (Nm)		iN	T2 (Nm)		iN	T2 (Nm)		iN	T2 (Nm)		iN	T2 (Nm)	
	PL0130	PL0230		PL0330	PL0530		PL0830	PL1230		PL1630	PL2530		PL4030	PL6530			
63.	1110	2050	56.	3400	5231	56.	9112	11277	56.	16539	56.	23350	56.	38509	56.	68250	
71.	1110	2050	71.	3400	5231	63.	9112	11277	63.	16539	63.	23350	71.	38509	63.	57400	
80.	1110	2050	80.	3400	5231	71.	9112	11277	80.	16539	71.	23350	80.	28559	71.	68250	
90.	1110	2050	90.	3400	5231	80.	9112	11277	90.	16539	80.	23350	90.	38509	80.	57400	
100	900	1661	100	2887	4442	90.	7840	9996	100	16539	90.	23350	100	38509	90.	68250	
112	1110	2050	112	3400	5231	100	9112	11277	112	12911	100	17657	112	38509	100	68250	
125	1110	2050	125	3400	5231	112	9112	11277	125	16539	112	23350	125	38509	112	68250	
140	1110	2050	140	3400	5231	125	9112	11277	140	16539	125	23350	140	28559	125	57400	
160	900	1661	160	2887	4442	140	7840	9996	160	16539	140	23350	160	38509	140	68250	
180	1110	2050	180	3400	5231	160	9112	11277	200	16539	160	17657	180	38509	160	68250	
225	1110	2050	200	3400	5231	180	9112	11277	225	12911	180	23350	200	28559	180	68250	
250	900	1661	250	2887	4442	225	7840	9996	250	12911	200	17657	250	28559	225	57400	
280	629	1162	280	2008	3089	250	5396	7196	280	7996	250	17657	280	23985	250	44680	
360	629	1162	315	2008	3089	280	5396	7196	315	7996	280	13339					
400	464	856	360	1494	2298	360	4564	6084									

iN	T2 (Nm)		iN	T2 (Nm)		iN	T2 (Nm)		iN	T2 (Nm)		iN	T2 (Nm)		iN	T2 (Nm)	
	PL0140	PL0240		PL0340	PL0540		PL0840	PL1240		PL1640	PL2540		PL4040	PL6540			
280	1110	2050	250	3400	5231	250	9112	11277	225	16539	200	23350	225	38509	225	68250	
315	1110	2050	315	3400	5231	315	9112	11277	280	16539	250	23350	280	38509	280	68250	
360	1110	2050	360	3400	5231	360	9112	11277	315	16539	280	23350	315	38509	315	68250	
450	1110	2050	400	3400	5231	400	9112	11277	360	16539	315	23350	360	38509	360	68250	
500	1110	2050	500	3400	5231	450	9112	11277	400	16539	360	23350	400	38509	400	68250	
560	1110	2050	560	3400	5231	500	9112	11277	500	16539	400	23350	450	38509	450	68250	
630	1110	2050	630	3400	5231	560	9112	11277	560	16539	450	23350	500	38509	500	68250	
710	1110	2050	710	3400	5231	630	9112	11277	630	16539	500	23350	560	38509	560	68250	
800	1110	2050	800	3400	5231	710	9112	11277	710	16539	630	23350	630	38509	630	68250	
900	1110	2050	900	3400	5231	800	9112	11277	800	16539	710	23350	710	28559	710	68250	
10C	1110	2050	10C	3400	5231	900	9112	11277	900	16539	800	23350	800	38509	800	68250	
11C	1110	2050	11C	3400	5231	10C	9112	11277	10C	16539	900	23350	900	28559	10C	68250	
14C	1110	2050	12C	3400	5231	11C	9112	11277	12C	16539	10C	23350	10C	38509	12C	68250	
16C	1110	2050	14C	3400	5231	12C	9112	11277	14C	16539	11C	23350	12C	38509	14C	57400	
18C	629	1162	16C	2008	3089	14C	5396	7196	16C	12911	12C	23350	14C	38509	16C	44680	
20C	900	1661	18C	2887	4442	16C	7840	9996	18C	12911	14C	17657	18C	28559			
22C	629	1162	20C	2008	3089	18C	5396	7196	20C	7996	16C	17657	20C	23985			
25C	629	1162	22C	2008	3089	20C	5396	7196	25C	7996	20C	13339					
32C	464	856	25C	1494	2298	25C	4564	6084									

NOMINAL TORQUE

Right Angle Units - Type PR

iN	T2 (Nm)		iN	T2 (Nm)		iN	T2 (Nm)		iN	T2 (Nm)
	PR0120	PR0220		PR0320	PL0520		PR0820	PR1220		PR1620
12.	1110	1594	14.	3400	3930	14.	8117	8117	16.	12876
14.	900	1661	18.	2887	4442	18.	7840	9723	20.	12911
18.	629	1162	22.	2008	3089	22.	5396	7196	25.	7996
22.	464	856	25.	1494	2298	25.	4564	6084		

iN	T2 (Nm)		iN	T2 (Nm)		iN	T2 (Nm)		iN	T2 (Nm)	iN	T2 (Nm)	iN	T2 (Nm)	iN	T2 (Nm)
	PR0130	PR0230		PR0330	PL0530		PR0830	PR1230		PR1630		PR2530		PR4030		
45.	1110	2050	45.	3400	5231	50.	9112	11277	56.	15230	56.	23350	63.	38509		
56.	1110	2050	56.	3400	5231	63.	9112	11277	63.	16539	63.	23350	71.	38509		
71.	900	1661	63.	2887	4442	71.	7840	9996	80.	16539	71.	17657	80.	28559		
80.	1110	2050	71.	3400	5231	80.	9112	11277	100	16539	90.	23350	100	28559		
90.	1110	2050	90.	3400	5231	100	9112	11277	112	12911	100	23350	112	38509		
112	900	1661	100	2887	4442	112	7840	9996	125	12911	112	17657	125	23985		
125	629	1162	112	2008	3089	125	5396	7196	140	7996	140	17657	140	28559		
140	629	1162	140	2008	3089	140	5396	7196	180	7996	160	13339	160	23985		
160	464	856	160	1494	2298	180	4564	6084								

iN	T2 (Nm)		iN	T2 (Nm)		iN	T2 (Nm)		iN	T2 (Nm)	iN	T2 (Nm)	iN	T2 (Nm)	iN	T2 (Nm)
	PR0140	PR0240		PR0340	PL0540		PR0840	PR1240		PR1640		PR2540		PR4040		PR6540
180	1110	2050	180	3400	5231	180	9112	11277	180	16539	200	23350	225	38509	225	68250
225	1110	2050	200	3400	5231	200	9112	11277	200	16539	250	23350	280	38509	280	68250
250	1110	2050	250	3400	5231	225	9112	11277	250	16539	280	17657	315	28559	315	57400
280	1110	2050	280	3400	5231	250	9112	11277	280	16539	315	23350	360	38509	360	68250
315	900	1661	315	2887	4442	280	7840	9996	315	16539	360	23350	400	38509	400	68250
360	1110	2050	360	3400	5231	315	9112	11277	360	12911	400	17657	450	38509	450	68250
400	1110	2050	400	3400	5231	360	9112	11277	400	16539	450	23350	500	28559	500	57400
450	1110	2050	450	3400	5231	400	9112	11277	450	16539	500	23350	560	28559	560	68250
500	900	1661	500	2887	4442	450	7840	9996	500	16539	560	23350	630	38509	630	57400
560	1110	2050	560	3400	5231	500	9112	11277	560	12911	630	17657	710	38509	710	44680
710	1110	2050	630	3400	5231	560	9112	11277	630	16539	710	23350	800	28559		
800	900	1661	710	2887	4442	630	5396	7196	710	12911	800	17657	900	28559		
900	629	1162	800	2008	3089	710	7840	9996	900	7996	900	17657	11C	23985		
11C	629	1162	10C	2008	3089	800	5396	7196	11C	7996	11C	13339				
13C	464	856	12C	1494	2298	900	5396	7196								
						11C	4564	6084								

SERIES P

INPUT SHAFT OVERHUNG LOADS Fr1

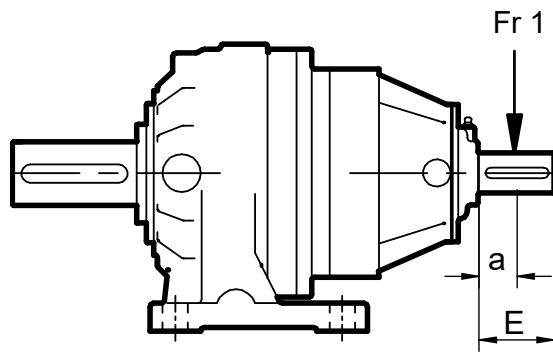

Unit	Curve	E
PL0110	1	70
PL0120	1	70
PL0130	1	70
PL0140	1	70
PL0210	1	70
PL0220	1	70
PL0230	1	70
PL0240	1	70

Unit	Curve	E
PL0310	2	82
PL0320	1	70
PL0330	1	70
PL0340	1	70
PL0510	2	82
PL0520	1	70
PL0530	1	70
PL0540	1	70

Unit	Curve	E
PL0810	3	105
PL0820	2	82
PL0830	1	70
PL0840	1	70
PL1210	3	105
PL1220	2	82
PL1230	1	70
PL1240	1	70

Unit	Curve	E
PL1610	4	130
PL1620	2	82
PL1630	1	70
PL1640	1	70
PL2510	5	170
PL2520	3	105
PL2530	2	82
PL2540	1	70

Unit	Curve	E
PL4010	6	190
PL4020	4	130
PL4030	2	82
PL4040	1	70
PL6510	7	210
PL6520	5	170
PL6530	3	105
PL6540	2	82

Unit	Curve	E
PR0120	1	70
PR0130	1	70
PR0140	1	70
PR0220	1	70
PR0230	1	70
PR0240	1	70

Unit	Curve	E
PR0320	1	70
PR0330	1	70
PR0340	1	70
PR0520	1	70
PR0530	1	70
PR0540	1	70

Unit	Curve	E
PR0820	2	82
PR0830	1	70
PR0840	1	70
PR1220	2	82
PR1230	1	70
PR1240	1	70

Unit	Curve	E
PR1620	2	82
PR1630	1	70
PR1640	1	70
PR2530	2	82
PR2540	1	70

Unit	Curve	E
PR4030	2	82
PR4030	1	70
PR6540	2	82

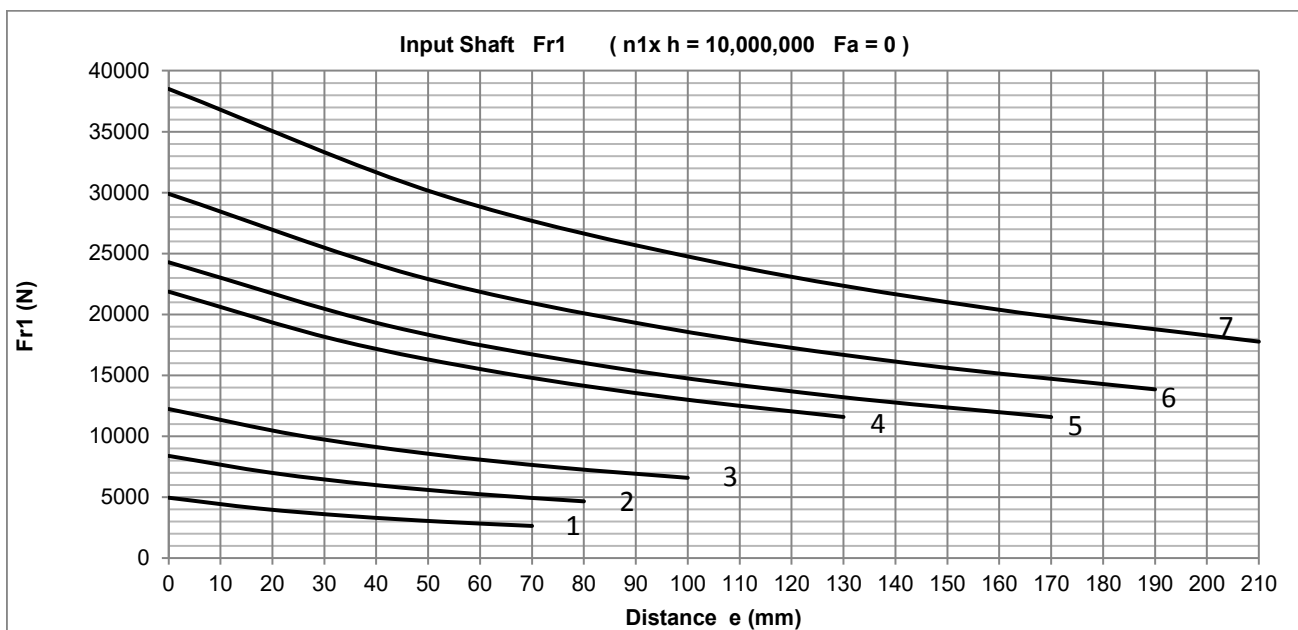

OUTPUT SHAFT OVERHUNG LOADS Fr2

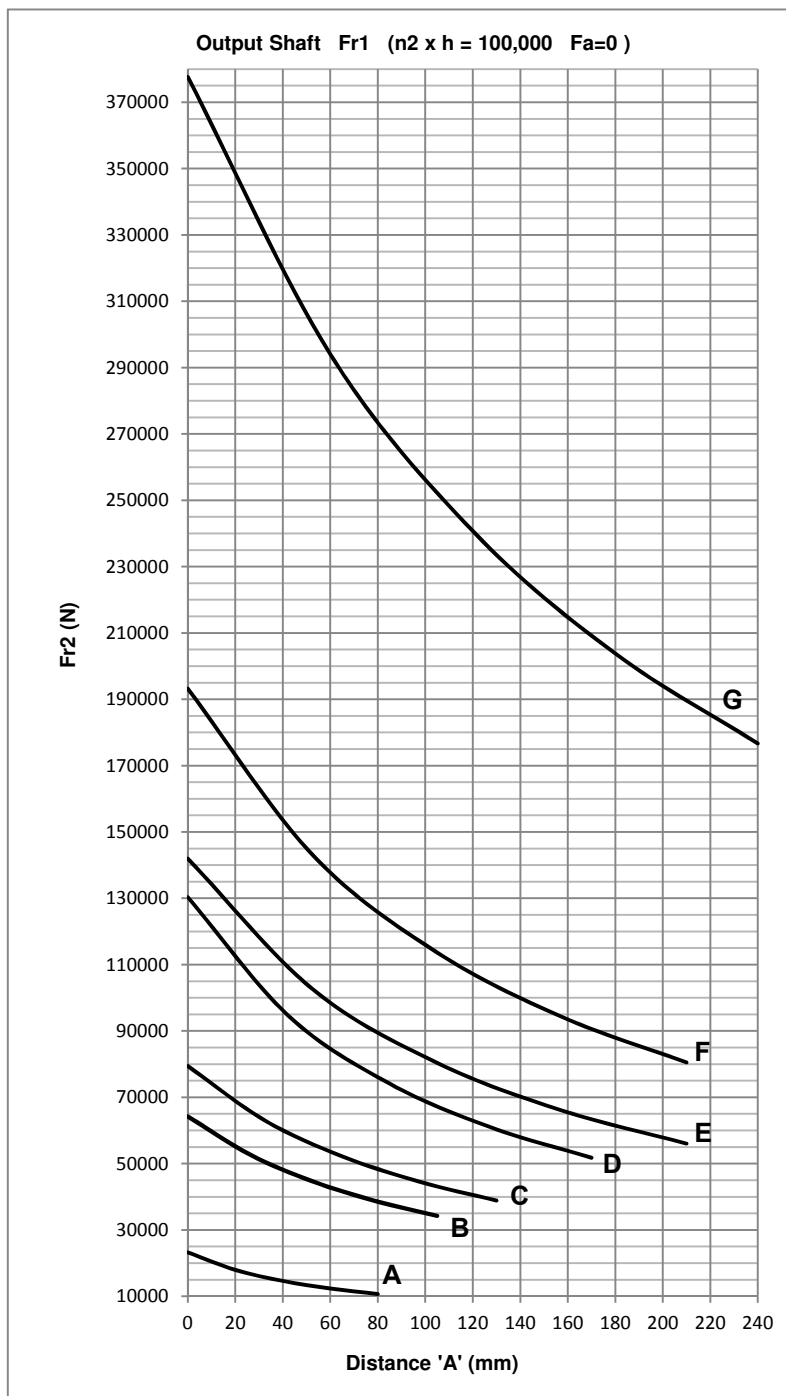
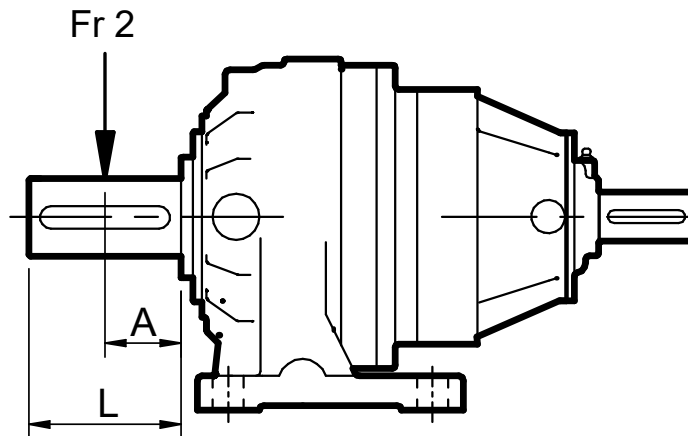

Unit	Curve	L
PL01	A	82
PR01		
PR02		
PR03		
PL03	B	105
PR03		
PL05		
PR05	C	130
PL08		
PR08		
PL12	C	130
PR12		
PL16	D	170
PR16		
PL25	E	210
PR25		
PL40	F	210
PR40		
PL65	G	240
PR65		

For alternative lifetime's adjust by factor Co

n2 x h	Co
1 000 000	0.50
500 000	0.62
100 000	1.00
50 000	1.23

PARALLEL UNITS
SERIES PL



SERIES P

PL01

Series	Ratio	Ratio	T2 (Nm) n2*h rating						n1 Max	Pt (kW) Type B	Pt (kW) Type F
			10,000	25,000	50,000	100,000	500,000	1,000,000			
PL0110	3.6	3.89	1305	1224	1207	1110	946	769	3500	15.5	13.8
	4.5	4.71	1220	1123	986	900	824	751		14.3	12.8
	6.3	6.20	895	753	660	629	575	552		13.0	11.6
	7.1	7.50	643	539	482	464	422	404		12.2	10.9
PL0120	16.	15.12	1305	1224	1207	1110	946	769	3500	9.6	8.7
	18.	18.33	1305	1224	1207	1110	946	769		9.4	8.5
	22.	22.22	1220	1123	986	900	824	751		9.1	8.2
	25.	24.11	1305	1224	1207	1110	946	769		9.1	8.2
	28.	29.17	1305	1224	1207	1110	946	769		8.8	8.0
	36.	35.36	1220	1123	986	900	824	751		8.6	7.8
	40.	38.44	895	753	660	629	575	552		8.5	7.7
	45.	46.50	895	753	660	629	575	552		8.4	7.5
PL0130	56.	56.25	643	539	482	464	422	404	3500	8.2	7.4
	63.	58.81	1305	1224	1207	1110	946	769		6.9	6.4
	71.	71.30	1305	1224	1207	1110	946	769		6.9	6.3
	80.	86.43	1305	1224	1207	1110	946	769		6.8	6.2
	90.	93.77	1305	1224	1207	1110	946	769		6.8	6.2
	100	104.8	1220	1123	986	900	824	751		6.7	6.2
	112	113.4	1305	1224	1207	1110	946	769		6.7	6.2
	125	137.5	1305	1224	1207	1110	946	769		6.7	6.1
	140	149.5	1305	1224	1207	1110	946	769		6.6	6.1
	160	166.7	1220	1123	986	900	824	751		6.6	6.0
	180	180.8	1305	1224	1207	1110	946	769		6.6	6.0
	225	218.8	1305	1224	1207	1110	946	769		6.5	6.0
	250	265.2	1220	1123	986	900	824	751		6.5	5.9
	280	288.3	895	753	660	629	575	552		6.4	5.9
PL0140	360	348.8	895	753	660	629	575	552	6.4	5.8	
	400	421.9	643	539	482	464	422	404	6.3	5.8	
	280	277.3	1305	1224	1207	1110	946	769	3500	5.6	5.2
	315	336.1	1305	1224	1207	1110	946	769		5.5	5.1
	360	364.6	1305	1224	1207	1110	946	769		5.3	4.9
	450	441.1	1305	1224	1207	1110	946	769		5.1	4.7
	500	534.7	1305	1224	1207	1110	946	769		4.7	4.3
	560	581.3	1305	1224	1207	1110	946	769		4.7	4.3
	630	648.2	1305	1224	1207	1110	946	769		4.7	4.3
	710	703.2	1305	1224	1207	1110	946	769		4.7	4.3
	800	850.7	1305	1224	1207	1110	946	769		4.6	4.3
	900	926.8	1305	1224	1207	1110	946	769		4.6	4.3
	10C	1031.3	1305	1224	1207	1110	946	769		4.6	4.3
	11C	1121.2	1305	1224	1207	1110	946	769		4.6	4.2
14C	1356.3	1305	1224	1207	1110	946	769	4.6		4.2	
16C	1640.6	1305	1224	1207	1110	946	769	4.6		4.2	
18C	1787.5	895	753	660	629	575	552	4.5	4.2		
20C	1988.8	1220	1123	986	900	824	751	4.5	4.2		
22C	2162.3	895	753	660	629	575	552	4.5	4.2		
25C	2615.6	895	753	660	629	575	552	4.5	4.2		
32C	3164.1	643	539	482	464	422	404	4.5	4.1		

SERIES P

PL01

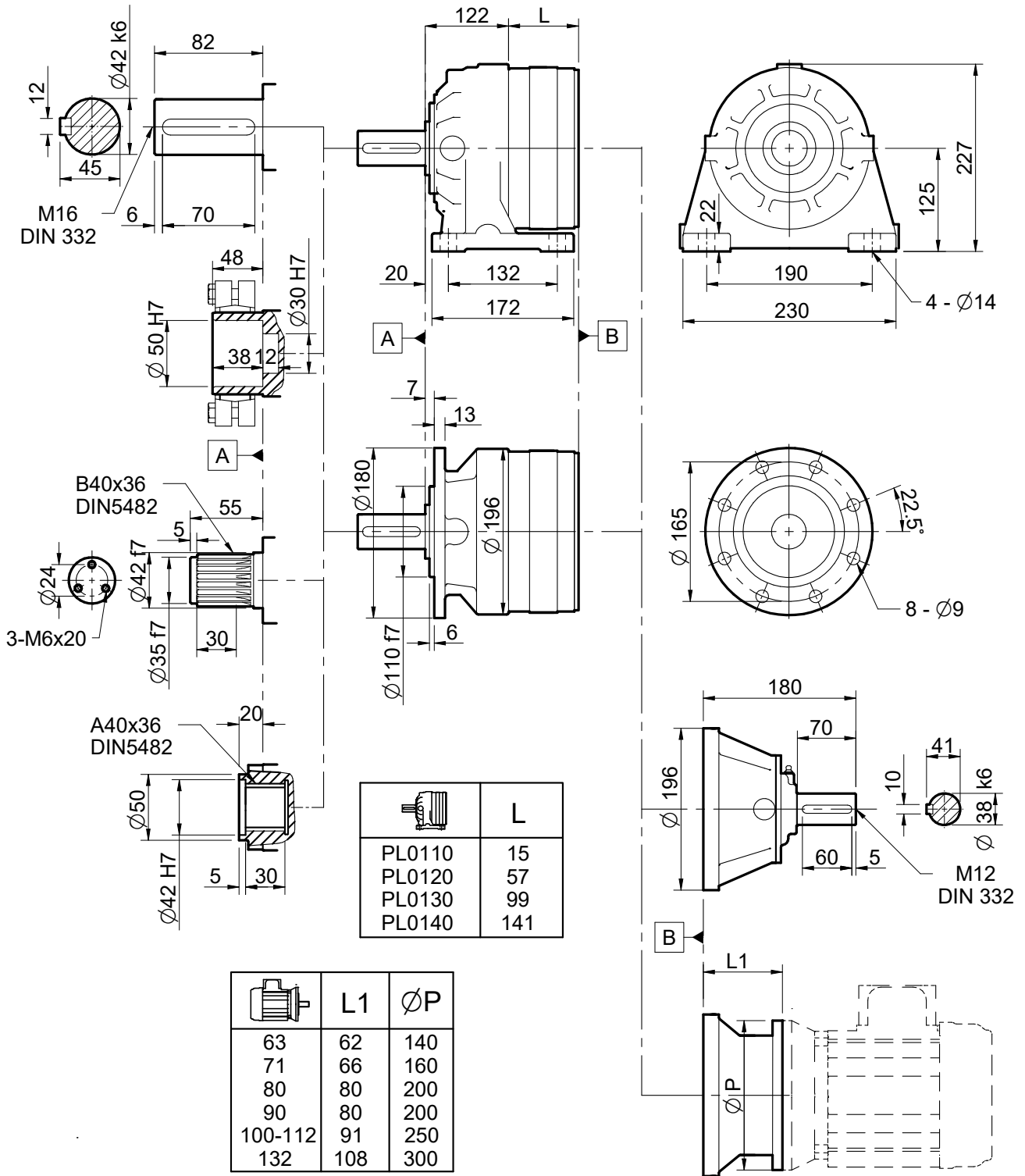

SERIES P

PL02

Series P	Ratio iN	Ratio i	T2 (Nm) n2*h rating						n1 Max	Pt (kW)	
			10,000	25,000	50,000	100,000	500,000	1,000,000		Type B	Type F
PL0210	3.6	3.89	2398	2247	2215	2050	1622	1317	3500	16.0	14.4
	4.5	4.71	2239	2074	1829	1661	1523	1286		14.8	13.3
	6.3	6.20	1655	1391	1219	1162	1063	1020		13.5	12.1
	7.1	7.50	1188	996	891	856	780	745		12.6	11.3
PL0220	16.	15.12	2398	2247	2215	2050	1622	1317	3500	10.4	9.5
	18.	18.33	2398	2247	2215	2050	1622	1317		10.2	9.2
	22.	22.22	2239	2074	1829	1661	1523	1286		9.9	9.0
	25.	24.11	2398	2247	2215	2050	1622	1317		9.8	8.9
	28.	29.17	2398	2247	2215	2050	1622	1317		9.6	8.7
	36.	35.36	2239	2074	1829	1661	1523	1286		9.4	8.5
	40.	38.44	1655	1391	1219	1162	1063	1020		9.3	8.4
	45.	46.50	1655	1391	1219	1162	1063	1020		9.1	8.2
56.	56.25	1188	996	891	856	780	745	8.9	8.0		
PL0230	63.	58.81	2398	2247	2215	2050	1622	1317	3500	7.1	6.5
	71.	71.30	2398	2247	2215	2050	1622	1317		7.1	6.5
	80.	86.43	2398	2247	2215	2050	1622	1317		7.0	6.4
	90.	93.77	2398	2247	2215	2050	1622	1317		7.0	6.4
	100	104.8	2239	2074	1829	1661	1523	1286		6.9	6.4
	112	113.4	2398	2247	2215	2050	1622	1317		6.9	6.3
	125	137.5	2398	2247	2215	2050	1622	1317		6.8	6.3
	140	149.5	2398	2247	2215	2050	1622	1317		6.8	6.3
	160	166.7	2239	2074	1829	1661	1523	1286		6.8	6.2
	180	180.8	2398	2247	2215	2050	1622	1317		6.8	6.2
	225	218.8	2398	2247	2215	2050	1622	1317		6.7	6.1
	250	265.2	2239	2074	1829	1661	1523	1286		6.6	6.1
	280	288.3	1655	1391	1219	1162	1063	1020		6.6	6.1
360	348.8	1655	1391	1219	1162	1063	1020	6.6	6.0		
400	421.9	1188	996	891	856	780	745	6.5	6.0		
PL0240	280	277.3	2398	2247	2215	2050	1622	1317	3500	5.7	5.3
	315	336.1	2398	2247	2215	2050	1622	1317		5.7	5.2
	360	364.6	2398	2247	2215	2050	1622	1317		5.4	5.0
	450	441.1	2398	2247	2215	2050	1622	1317		5.2	4.8
	500	534.7	2398	2247	2215	2050	1622	1317		4.8	4.4
	560	581.3	2398	2247	2215	2050	1622	1317		4.8	4.4
	630	648.2	2398	2247	2215	2050	1622	1317		4.8	4.4
	710	703.2	2398	2247	2215	2050	1622	1317		4.8	4.4
	800	850.7	2398	2247	2215	2050	1622	1317		4.8	4.4
	900	926.8	2398	2247	2215	2050	1622	1317		4.7	4.4
	10C	1031.3	2398	2247	2215	2050	1622	1317		4.7	4.4
	11C	1121.2	2398	2247	2215	2050	1622	1317		4.7	4.4
	14C	1356.3	2398	2247	2215	2050	1622	1317		4.7	4.3
	16C	1640.6	2398	2247	2215	2050	1622	1317		4.7	4.3
	18C	1787.5	1655	1391	1219	1162	1063	1020		4.7	4.3
	20C	1988.8	2239	2074	1829	1661	1523	1286		4.6	4.3
	22C	2162.3	1655	1391	1219	1162	1063	1020		4.6	4.3
25C	2615.6	1655	1391	1219	1162	1063	1020	4.6	4.3		
32C	3164.1	1188	996	891	856	780	745	4.6	4.3		

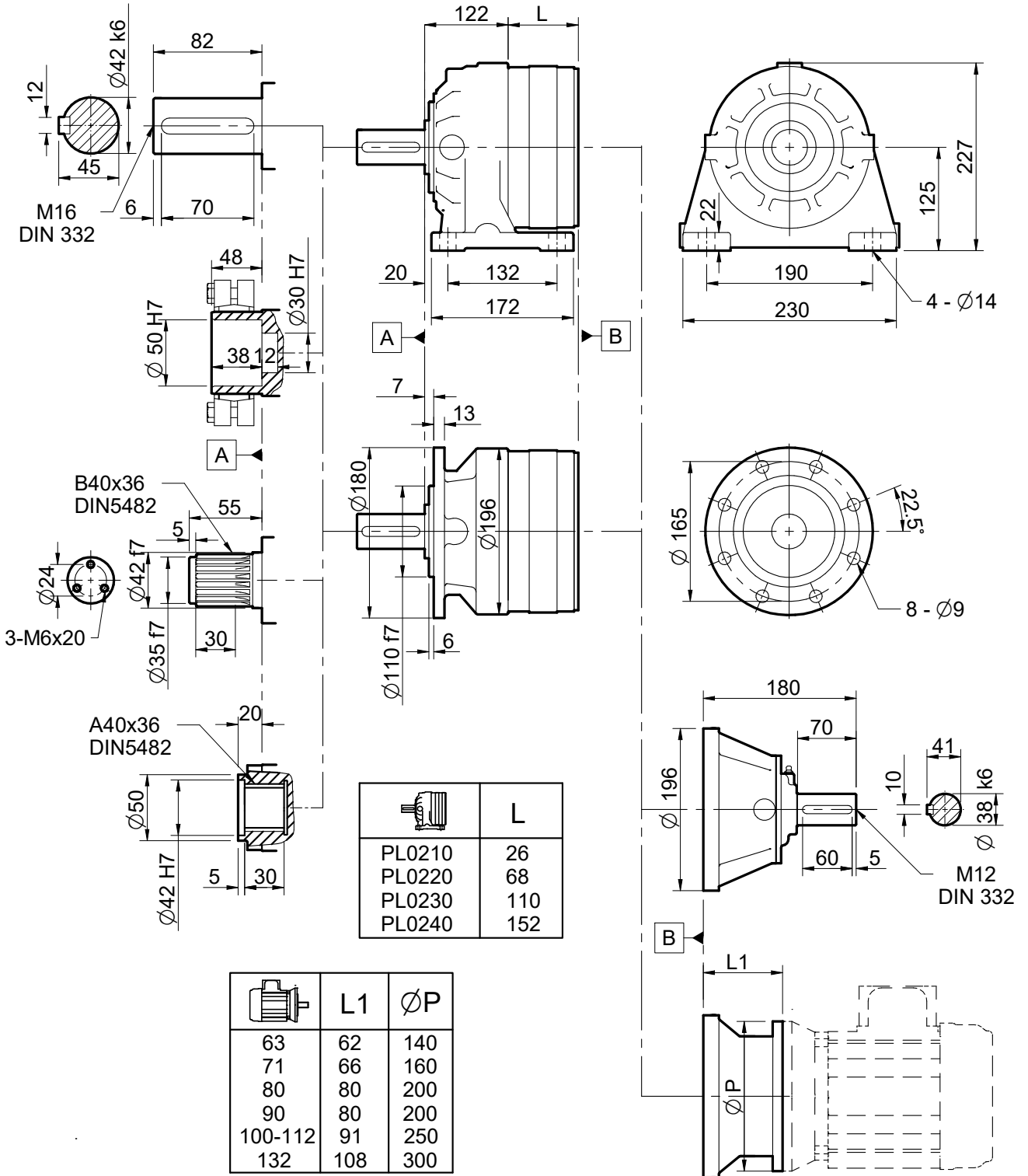

SERIES P

PL03

Series P	Ratio iN	Ratio i	T2 (Nm) n2*h rating						n1 Max	Pt (kW)	
			10,000	25,000	50,000	100,000	500,000	1,000,000		Type B	Type F
PL0310	3.6	3.64	3930	3700	3648	3400	2536	2060	2800	27.3	26.1
	4.5	4.36	3598	3350	3199	2887	2493	2025		25.4	24.3
	5.6	5.63	2891	2432	2137	2008	1838	1765		23.1	22.1
	7.1	6.69	2100	1764	1553	1494	1364	1306		21.8	20.9
PL0320	14.	14.17	3930	3700	3648	3400	2536	2060	3500	15.6	14.9
	16.	17.17	3930	3700	3648	3400	2536	2060		15.2	14.5
	20.	20.57	3598	3350	3199	2887	2493	2025		14.8	14.2
	22.	22.59	3930	3700	3648	3400	2536	2060		14.6	14.0
	25.	27.32	3930	3700	3648	3400	2536	2060		14.3	13.7
	32.	32.73	3598	3350	3199	2887	2493	2025		14.0	13.4
	36.	34.88	2891	2432	2137	2008	1838	1765		13.8	13.3
	45.	42.19	2891	2432	2137	2008	1838	1765		13.5	13.0
50.	50.19	2100	1764	1553	1494	1364	1306	13.3	12.7		
PL0330	56.	55.09	3930	3700	3648	3400	2536	2060	3500	10.2	9.8
	71.	66.79	3930	3700	3648	3400	2536	2060		10.1	9.7
	80.	80.96	3930	3700	3648	3400	2536	2060		10.0	9.7
	90.	87.83	3930	3700	3648	3400	2536	2060		10.0	9.6
	100	96.98	3598	3350	3199	2887	2493	2025		10.0	9.6
	112	106.5	3930	3700	3648	3400	2536	2060		9.9	9.5
	125	128.8	3930	3700	3648	3400	2536	2060		9.8	9.4
	140	140.0	3930	3700	3648	3400	2536	2060		9.8	9.4
	160	154.3	3598	3350	3199	2887	2493	2025		9.7	9.4
	180	169.4	3930	3700	3648	3400	2536	2060		9.7	9.3
	200	204.9	3930	3700	3648	3400	2536	2060		9.6	9.2
	250	245.5	3598	3350	3199	2887	2493	2025		9.5	9.2
	280	261.6	2891	2432	2137	2008	1838	1765		9.5	9.1
	315	316.4	2891	2432	2137	2008	1838	1765		9.4	9.0
360	376.4	2100	1764	1553	1494	1364	1306	9.3	9.0		
PL0340	250	259.7	3930	3700	3648	3400	2536	2060	3500	8.0	7.7
	315	314.8	3930	3700	3648	3400	2536	2060		7.9	7.6
	360	341.6	3930	3700	3648	3400	2536	2060		7.5	7.2
	400	413.2	3930	3700	3648	3400	2536	2060		7.3	7.0
	500	500.9	3930	3700	3648	3400	2536	2060		7.3	7.0
	560	544.6	3930	3700	3648	3400	2536	2060		7.2	7.0
	630	607.2	3930	3700	3648	3400	2536	2060		7.2	7.0
	710	658.8	3930	3700	3648	3400	2536	2060		7.2	6.9
	800	796.9	3930	3700	3648	3400	2536	2060		7.2	6.9
	900	868.2	3930	3700	3648	3400	2536	2060		7.2	6.9
	10C	966.0	3930	3700	3648	3400	2536	2060		7.1	6.9
	11C	1050.2	3930	3700	3648	3400	2536	2060		7.1	6.9
	12C	1270.4	3930	3700	3648	3400	2536	2060		7.1	6.8
	14C	1536.8	3930	3700	3648	3400	2536	2060		7.1	6.8
	16C	1621.7	2891	2432	2137	2008	1838	1765		7.0	6.8
	18C	1840.9	3598	3350	3199	2887	2493	2025		7.0	6.8
	20C	1961.7	2891	2432	2137	2008	1838	1765		7.0	6.8
22C	2373.0	2891	2432	2137	2008	1838	1765	7.0	6.7		
25C	2823.3	2100	1764	1553	1494	1364	1306	6.9	6.7		

SERIES P

PL03

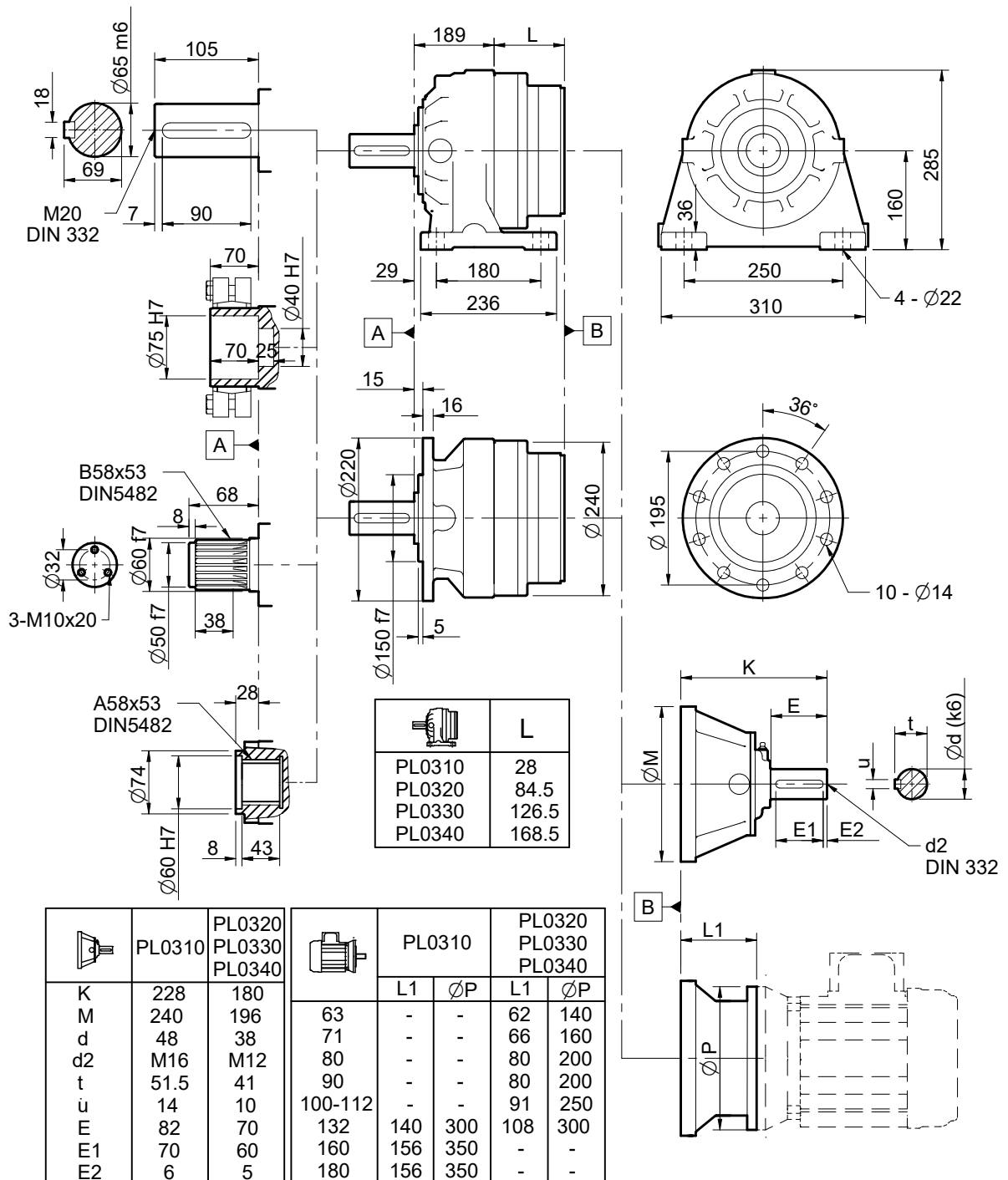

SERIES P

PL05

Series P	Ratio iN	Ratio i	T2 (Nm) n2*h rating						n1 Max	Pt (kW)	
			10,000	25,000	50,000	100,000	500,000	1,000,000		Type B	Type F
PL0510	3.6	3.64	6028	5675	5595	5231	3556	2889	2800	28.1	27.0
	4.5	4.36	5519	5139	4920	4442	3498	2841		26.2	25.1
	5.6	5.63	4448	3742	3287	3089	2828	2716		23.8	22.9
	7.1	6.69	3232	2715	2389	2298	2099	2010		22.4	21.5
PL0520	14.	14.17	6028	5675	5595	5231	3556	2889	3500	16.4	15.7
	16.	17.17	6028	5675	5595	5231	3556	2889		16.0	15.3
	20.	20.57	5519	5139	4920	4442	3498	2841		15.6	15.0
	22.	22.59	6028	5675	5595	5231	3556	2889		15.4	14.8
	25.	27.32	6028	5675	5595	5231	3556	2889		15.0	14.4
	32.	32.73	5519	5139	4920	4442	3498	2841		14.7	14.1
	36.	34.88	4448	3742	3287	3089	2828	2716		14.6	14.0
	45.	42.19	4448	3742	3287	3089	2828	2716		14.2	13.7
50.	50.19	3232	2715	2389	2298	2099	2010	14.0	13.4		
PL0530	56.	55.09	6028	5675	5595	5231	3556	2889	3500	10.7	10.3
	71.	66.79	6028	5675	5595	5231	3556	2889		10.6	10.2
	80.	80.96	6028	5675	5595	5231	3556	2889		10.5	10.1
	90.	87.83	6028	5675	5595	5231	3556	2889		10.5	10.1
	100	96.98	5519	5139	4920	4442	3498	2841		10.4	10.1
	112	106.5	6028	5675	5595	5231	3556	2889		10.4	10.0
	125	128.8	6028	5675	5595	5231	3556	2889		10.3	9.9
	140	140.0	6028	5675	5595	5231	3556	2889		10.3	9.9
	160	154.3	5519	5139	4920	4442	3498	2841		10.2	9.8
	180	169.4	6028	5675	5595	5231	3556	2889		10.2	9.8
	200	204.9	6028	5675	5595	5231	3556	2889		10.1	9.7
	250	245.5	5519	5139	4920	4442	3498	2841		10.0	9.6
	280	261.6	4448	3742	3287	3089	2828	2716		10.0	9.6
	315	316.4	4448	3742	3287	3089	2828	2716		9.9	9.5
360	376.4	3232	2715	2389	2298	2099	2010	9.8	9.4		
PL0540	250	259.7	6028	5675	5595	5231	3556	2889	3500	8.4	8.1
	315	314.8	6028	5675	5595	5231	3556	2889		8.2	7.9
	360	341.6	6028	5675	5595	5231	3556	2889		7.8	7.6
	400	413.2	6028	5675	5595	5231	3556	2889		7.6	7.4
	500	500.9	6028	5675	5595	5231	3556	2889		7.6	7.3
	560	544.6	6028	5675	5595	5231	3556	2889		7.6	7.3
	630	607.2	6028	5675	5595	5231	3556	2889		7.6	7.3
	710	658.8	6028	5675	5595	5231	3556	2889		7.5	7.3
	800	796.9	6028	5675	5595	5231	3556	2889		7.5	7.2
	900	868.2	6028	5675	5595	5231	3556	2889		7.5	7.2
	10C	966.0	6028	5675	5595	5231	3556	2889		7.5	7.2
	11C	1050.2	6028	5675	5595	5231	3556	2889		7.4	7.2
	12C	1270.4	6028	5675	5595	5231	3556	2889		7.4	7.2
	14C	1536.8	6028	5675	5595	5231	3556	2889		7.4	7.1
	16C	1621.7	4448	3742	3287	3089	2828	2716		7.4	7.1
	18C	1840.9	5519	5139	4920	4442	3498	2841		7.3	7.1
	20C	1961.7	4448	3742	3287	3089	2828	2716		7.3	7.1
22C	2373.0	4448	3742	3287	3089	2828	2716	7.3	7.0		
25C	2823.3	3232	2715	2389	2298	2099	2010	7.3	7.0		

SERIES P

PL05

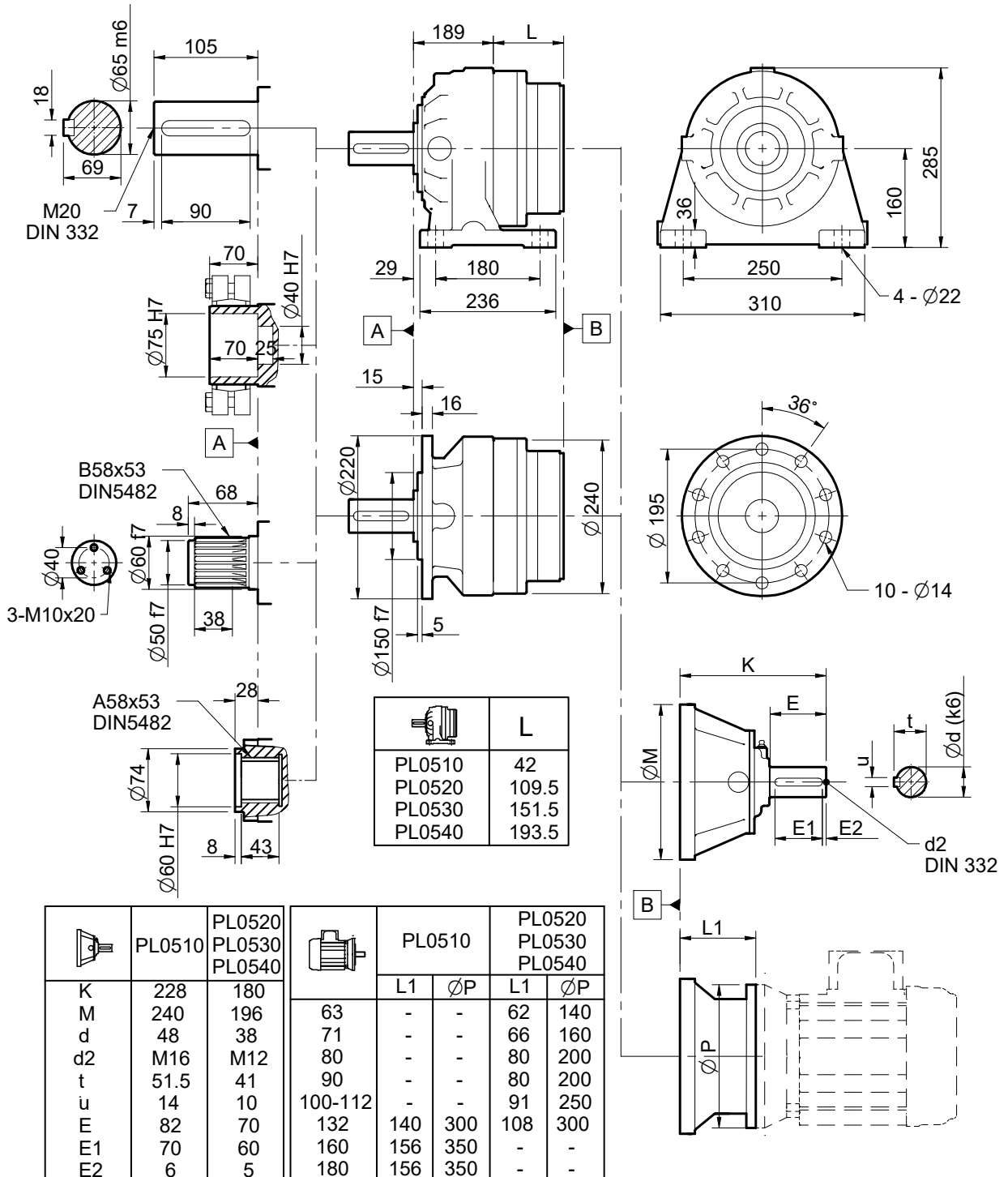

SERIES P

PL08

Series P	Ratio iN	Ratio i	T2 (Nm) n2*h rating						n1 Max	Pt (kW) Type B	Pt (kW) Type F
			10,000	25,000	50,000	100,000	500,000	1,000,000			
PL0810	3.6	3.64	10669	10034	9889	9112	5622	4567	2500	40.4	37.5
	4.5	4.36	10055	9330	8295	7840	5502	4469		37.5	34.8
	5.6	5.63	7742	6521	5734	5396	4949	4341		34.0	31.6
	7.1	6.69	6389	5377	4740	4564	4180	4014		32.0	29.7
PL0820	14.	13.27	10669	10034	9889	9112	5622	4567	2800	27.2	25.4
	16.	15.90	10669	10034	9889	9112	5622	4567		26.5	24.8
	20.	19.04	10055	9330	8295	7840	5502	4469		25.8	24.1
	22.	20.49	10669	10034	9889	9112	5622	4567		25.5	23.9
	25.	24.38	10669	10034	9889	9112	5622	4567		24.9	23.3
	28.	29.20	10055	9330	8295	7840	5502	4469		24.3	22.8
	32.	31.64	7742	6521	5734	5396	4949	4341		24.0	22.5
	36.	37.64	7742	6521	5734	5396	4949	4341		23.5	22.0
45.	44.79	6389	5377	4740	4564	4180	4014	23.0	21.5		
PL0830	56.	51.61	10669	10034	9889	9112	5622	4567	3500	16.0	15.0
	63.	62.56	10669	10034	9889	9112	5622	4567		15.9	14.9
	71.	74.94	10669	10034	9889	9112	5622	4567		15.7	14.7
	80.	82.28	10669	10034	9889	9112	5622	4567		15.7	14.7
	90.	89.77	10055	9330	8295	7840	5502	4469		15.6	14.6
	100	98.56	10669	10034	9889	9112	5622	4567		15.5	14.5
	112	119.2	10669	10034	9889	9112	5622	4567		15.4	14.4
	125	127.0	10669	10034	9889	9112	5622	4567		15.3	14.3
	140	142.8	10055	9330	8295	7840	5502	4469		15.2	14.3
	160	153.7	10669	10034	9889	9112	5622	4567		15.2	14.2
	180	182.8	10669	10034	9889	9112	5622	4567		15.0	14.1
	225	219.0	10055	9330	8295	7840	5502	4469		14.9	14.0
	250	237.3	7742	6521	5734	5396	4949	4341		14.9	13.9
280	282.3	7742	6521	5734	5396	4949	4341	14.7	13.8		
360	335.9	6389	5377	4740	4564	4180	4014	14.6	13.7		
PL0840	250	243.3	10669	10034	9889	9112	5622	4567	3500	11.7	11.0
	315	294.9	10669	10034	9889	9112	5622	4567		11.5	10.8
	360	320.0	10669	10034	9889	9112	5622	4567		11.1	10.4
	400	387.1	10669	10034	9889	9112	5622	4567		10.8	10.2
	450	469.2	10669	10034	9889	9112	5622	4567		10.8	10.1
	500	510.1	10669	10034	9889	9112	5622	4567		10.8	10.1
	560	562.0	10669	10034	9889	9112	5622	4567		10.7	10.1
	630	617.1	10669	10034	9889	9112	5622	4567		10.7	10.1
	710	746.5	10669	10034	9889	9112	5622	4567		10.6	10.0
	800	787.7	10669	10034	9889	9112	5622	4567		10.6	10.0
	900	894.2	10669	10034	9889	9112	5622	4567		10.6	10.0
	10C	952.8	10669	10034	9889	9112	5622	4567		10.6	9.9
	11C	1152.6	10669	10034	9889	9112	5622	4567		10.5	9.9
	12C	1371.3	10669	10034	9889	9112	5622	4567		10.5	9.8
	14C	1471.3	7742	6521	5734	5396	4949	4341		10.5	9.8
	16C	1642.7	10055	9330	8295	7840	5502	4469		10.4	9.8
	18C	1779.8	7742	6521	5734	5396	4949	4341		10.4	9.8
	20C	2117.5	7742	6521	5734	5396	4949	4341		10.4	9.7
25C	2519.3	6389	5377	4740	4564	4180	4014	10.3	9.7		

SERIES P

PL08

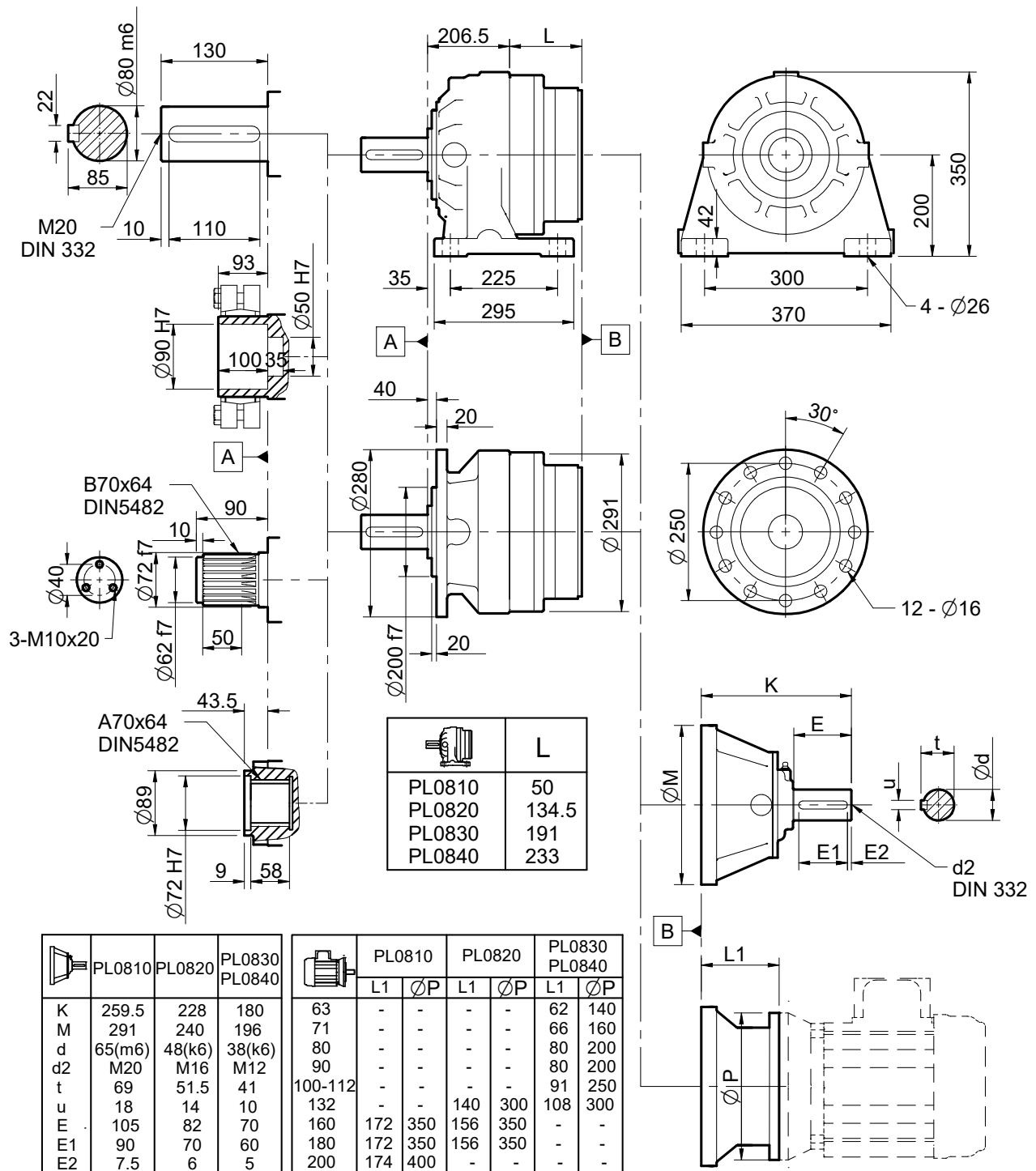

SERIES P

PL12

Series P	Ratio iN	Ratio i	T2 (Nm) n2*h rating						n1 Max	Pt (kW) Type B	Pt (kW) Type F
			10,000	25,000	50,000	100,000	500,000	1,000,000			
PL1210	3.6	3.64	14202	13356	13168	11277	6958	5652	2500	41.6	38.8
	4.5	4.36	13385	12420	11064	9996	6813	5534		38.6	36.0
	5.6	5.63	10324	8700	7655	7196	6597	5375		35.1	32.6
	7.1	6.69	8519	7170	6323	6084	5573	5325		33.0	30.7
PL1220	14.	13.27	14202	13356	13168	11277	6958	5652	2800	28.5	26.7
	16.	15.90	14202	13356	13168	11277	6958	5652		27.7	26.0
	20.	19.04	13385	12420	11064	9996	6813	5534		27.0	25.4
	22.	20.49	14202	13356	13168	11277	6958	5652		26.7	25.1
	25.	24.38	14202	13356	13168	11277	6958	5652		26.1	24.5
	28.	29.20	13385	12420	11064	9996	6813	5534		25.4	23.9
	32.	31.64	10324	8700	7655	7196	6597	5375		25.2	23.6
	36.	37.64	10324	8700	7655	7196	6597	5375		24.6	23.1
PL1230	45.	44.79	8519	7170	6323	6084	5573	5325	3500	24.1	22.6
	56.	51.61	14202	13356	13168	11277	6958	5652		17.0	16.0
	63.	62.56	14202	13356	13168	11277	6958	5652		16.8	15.8
	71.	74.94	14202	13356	13168	11277	6958	5652		16.7	15.7
	80.	82.28	14202	13356	13168	11277	6958	5652		16.6	15.6
	90.	89.77	13385	12420	11064	9996	6813	5534		16.5	15.5
	100	98.56	14202	13356	13168	11277	6958	5652		16.4	15.5
	112	119.2	14202	13356	13168	11277	6958	5652		16.3	15.3
	125	127.0	14202	13356	13168	11277	6958	5652		16.2	15.3
	140	142.8	13385	12420	11064	9996	6813	5534		16.1	15.2
	160	153.7	14202	13356	13168	11277	6958	5652		16.1	15.1
	180	182.8	14202	13356	13168	11277	6958	5652		15.9	15.0
	225	219.0	13385	12420	11064	9996	6813	5534		15.8	14.9
	250	237.3	10324	8700	7655	7196	6597	5375		15.7	14.8
PL1240	280	282.3	10324	8700	7655	7196	6597	5375	15.6	14.7	
	360	335.9	8519	7170	6323	6084	5573	5325	15.5	14.6	
	250	243.3	14202	13356	13168	11277	6958	5652	3500	12.3	11.6
	315	294.9	14202	13356	13168	11277	6958	5652		12.1	11.4
	360	320.0	14202	13356	13168	11277	6958	5652		11.8	11.1
	400	387.1	14202	13356	13168	11277	6958	5652		11.5	10.8
	450	469.2	14202	13356	13168	11277	6958	5652		11.4	10.7
	500	510.1	14202	13356	13168	11277	6958	5652		11.4	10.7
	560	562.0	14202	13356	13168	11277	6958	5652		11.3	10.7
	630	617.1	14202	13356	13168	11277	6958	5652		11.3	10.7
	710	746.5	14202	13356	13168	11277	6958	5652		11.3	10.6
	800	787.7	14202	13356	13168	11277	6958	5652		11.2	10.6
	900	894.2	14202	13356	13168	11277	6958	5652		11.2	10.6
	10C	952.8	14202	13356	13168	11277	6958	5652		11.2	10.5
11C	1152.6	14202	13356	13168	11277	6958	5652	11.1		10.5	
12C	1371.3	14202	13356	13168	11277	6958	5652	11.1		10.4	
14C	1471.3	10324	8700	7655	7196	6597	5375	11.1	10.4		
16C	1642.7	13385	12420	11064	9996	6813	5534	11.0	10.4		
18C	1779.8	10324	8700	7655	7196	6597	5375	11.0	10.4		
20C	2117.5	10324	8700	7655	7196	6597	5375	10.9	10.3		
25C	2519.3	8519	7170	6323	6084	5573	5325	10.9	10.3		

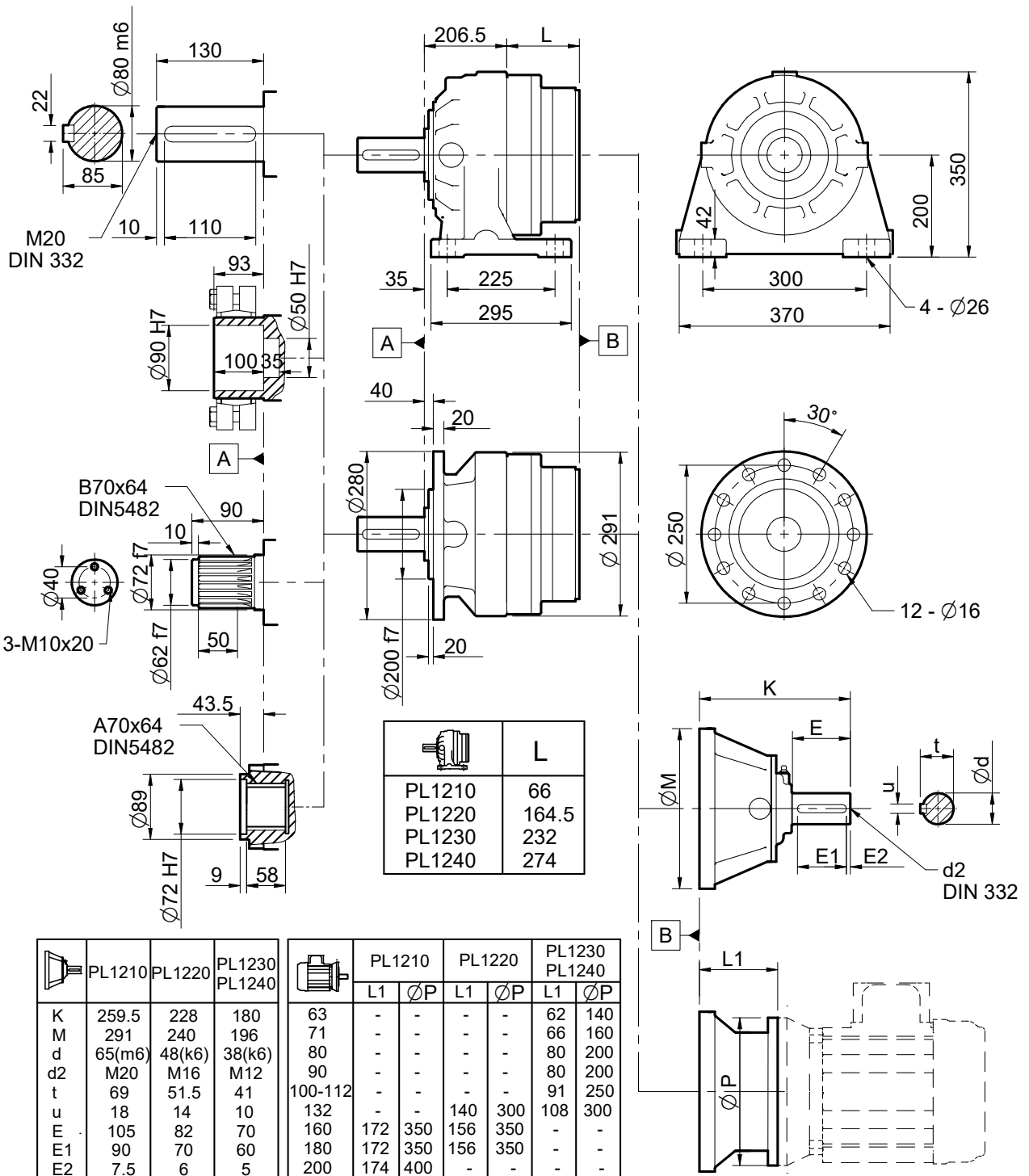

SERIES P

PL16

Series P	Ratio iN	Ratio i	T2 (Nm) n2*h rating						n1 Max	Pt (kW)	
			10,000	25,000	50,000	100,000	500,000	1,000,000		Type B	Type F
PL1610	4.0	3.88	21112	19780	18800	16539	10205	8289	2300	76.9	52.3
	5.0	4.83	18850	15898	14030	12911	9936	8071		70.4	47.8
	7.1	6.75	11138	9395	8310	7996	7327	7025		62.4	42.4
PL1620	14.	14.12	21112	19780	18800	16539	10205	8289	2800	50.2	34.5
	16.	16.91	21112	19780	18800	16539	10205	8289		48.9	33.6
	22.	21.80	21112	19780	18800	16539	10205	8289		47.0	32.3
	25.	25.93	21112	19780	18800	16539	10205	8289		45.9	31.5
	28.	27.19	18850	15898	14030	12911	9936	8071		45.6	31.3
	32.	32.35	18850	15898	14030	12911	9936	8071		44.5	30.6
	36.	37.97	11138	9395	8310	7996	7327	7025		43.5	29.9
	45.	45.17	11138	9395	8310	7996	7327	7025		42.5	29.2
PL1630	56.	54.90	21112	19780	18800	16539	10205	8289	3500	29.5	20.4
	63.	66.55	21112	19780	18800	16539	10205	8289		29.2	20.2
	80.	79.71	21112	19780	18800	16539	10205	8289		29.0	20.0
	90.	87.52	21112	19780	18800	16539	10205	8289		28.8	19.9
	100	105.87	21112	19780	18800	16539	10205	8289		28.5	19.7
	112	109.16	18850	15898	14030	12911	9936	8071		28.5	19.6
	125	126.82	21112	19780	18800	16539	10205	8289		28.3	19.5
	140	135.14	21112	19780	18800	16539	10205	8289		28.2	19.4
	160	163.48	21112	19780	18800	16539	10205	8289		27.9	19.2
	200	194.50	21112	19780	18800	16539	10205	8289		27.7	19.1
	225	203.91	18850	15898	14030	12911	9936	8071		27.6	19.0
	250	242.60	18850	15898	14030	12911	9936	8071		27.4	18.9
	280	284.77	11138	9395	8310	7996	7327	7025		27.1	18.7
315	338.80	11138	9395	8310	7996	7327	7025	26.9	18.6		
PL1640	225	213.5	21112	19780	18800	16539	10205	8289	3500	21.4	14.9
	280	258.8	21112	19780	18800	16539	10205	8289		21.4	14.9
	315	313.7	21112	19780	18800	16539	10205	8289		19.7	13.7
	360	340.4	21112	19780	18800	16539	10205	8289		19.4	13.5
	400	411.7	21112	19780	18800	16539	10205	8289		19.4	13.5
	500	499.1	21112	19780	18800	16539	10205	8289		19.3	13.5
	560	542.6	21112	19780	18800	16539	10205	8289		19.3	13.4
	630	597.9	21112	19780	18800	16539	10205	8289		19.2	13.4
	710	656.4	21112	19780	18800	16539	10205	8289		19.2	13.4
	800	794.0	21112	19780	18800	16539	10205	8289		19.1	13.3
	900	951.1	21112	19780	18800	16539	10205	8289		19.0	13.2
	10C	1013.6	21112	19780	18800	16539	10205	8289		18.9	13.2
	12C	1226.1	21112	19780	18800	16539	10205	8289		18.9	13.1
	14C	1458.7	21112	19780	18800	16539	10205	8289		18.8	13.1
	16C	1504.1	18850	15898	14030	12911	9936	8071		18.7	13.1
	18C	1819.5	18850	15898	14030	12911	9936	8071		18.7	13.0
	20C	2100.5	11138	9395	8310	7996	7327	7025		18.6	13.0
25C	2541.0	11138	9395	8310	7996	7327	7025	18.5	12.9		

SERIES P

PL16

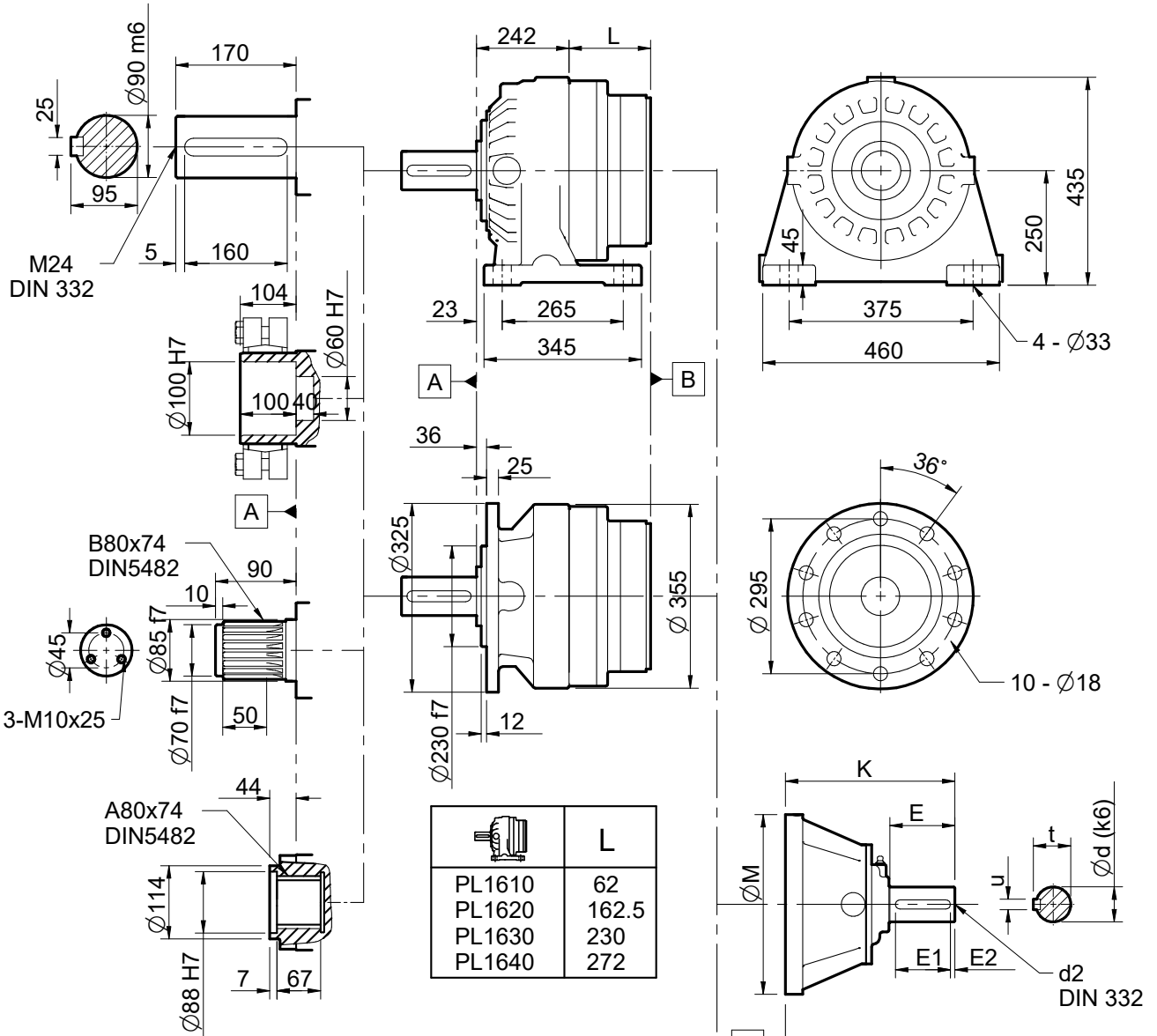

	PL1610	PL1620	PL1630 PL1640
K	313	228	180
M	355	240	196
d	80(m6)	48(k6)	38(k6)
d2	M20	M16	M12
t	85	51.5	41
u	22	14	10
E	130	82	70
E1	110	70	60
E2	10	6	5

	PL1610		PL1620		PL1630 PL1640	
	L1	ØP	L1	ØP	L1	ØP
63	-	-	-	-	62	140
71	-	-	-	-	66	160
80	-	-	-	-	80	200
90	-	-	-	-	80	200
100-112	-	-	-	-	91	250
132	-	-	140	300	108	300
160	-	-	156	350	-	-
180	-	-	156	350	-	-
200	176	400	-	-	-	-
225	204	450	-	-	-	-

SERIES P

PL25

Series P	Ratio iN	Ratio i	T2 (Nm) n2*h rating						n1 Max	Pt (kW) Type B	Pt (kW) Type F
			10,000	25,000	50,000	100,000	500,000	1,000,000			
PL2510	4.0	4.00	32666	29569	26126	23350	15648	12710	2000	-	55.5
	5.0	5.20	25385	21500	18990	17657	15258	12394		-	50.0
	6.3	6.25	18707	15813	13944	13339	12250	11780		-	46.8
PL2520	14.	14.57	32666	29569	26126	23350	15648	12710	2500	-	37.4
	18.	17.45	32666	29569	26126	23350	15648	12710		-	36.4
	22.	22.50	32666	29569	26126	23350	15648	12710		-	35.0
	25.	26.77	32666	29569	26126	23350	15648	12710		-	34.2
	28.	29.25	25385	21500	18990	17657	15258	12394		-	33.7
	32.	34.80	25385	21500	18990	17657	15258	12394		-	32.9
	36.	35.16	18707	15813	13944	13339	12250	11780		-	32.9
	40.	41.83	18707	15813	13944	13339	12250	11780		-	32.1
PL2530	56.	53.08	32666	29569	26126	23350	15648	12710	2800	-	22.1
	63.	63.58	32666	29569	26126	23350	15648	12710		-	21.9
	71.	76.17	32666	29569	26126	23350	15648	12710		-	21.7
	80.	81.96	32666	29569	26126	23350	15648	12710		-	21.6
	90.	97.52	32666	29569	26126	23350	15648	12710		-	21.4
	100	106.55	25385	21500	18990	17657	15258	12394		-	21.3
	112	116.81	32666	29569	26126	23350	15648	12710		-	21.2
	125	126.56	32666	29569	26126	23350	15648	12710		-	21.1
	140	150.58	32666	29569	26126	23350	15648	12710		-	20.9
	160	164.53	25385	21500	18990	17657	15258	12394		-	20.8
	180	179.15	32666	29569	26126	23350	15648	12710		-	20.8
	200	195.75	25385	21500	18990	17657	15258	12394		-	20.7
	250	232.89	25385	21500	18990	17657	15258	12394		-	20.5
280	279.92	18707	15813	13944	13339	12250	11780	-	20.3		
PL2540	200	206.43	32666	29569	26126	23350	15648	12710	3500	-	15.8
	250	250.24	32666	29569	26126	23350	15648	12710		-	15.6
	280	299.76	32666	29569	26126	23350	15648	12710		-	14.6
	315	329.11	32666	29569	26126	23350	15648	12710		-	14.2
	360	359.06	32666	29569	26126	23350	15648	12710		-	14.2
	400	398.11	32666	29569	26126	23350	15648	12710		-	14.2
	450	476.88	32666	29569	26126	23350	15648	12710		-	14.1
	500	508.18	32666	29569	26126	23350	15648	12710		-	14.1
	630	614.73	32666	29569	26126	23350	15648	12710		-	14.0
	710	731.37	32666	29569	26126	23350	15648	12710		-	13.9
	800	784.69	32666	29569	26126	23350	15648	12710		-	13.9
	900	876.08	32666	29569	26126	23350	15648	12710		-	13.8
	10C	949.22	32666	29569	26126	23350	15648	12710		-	13.8
	11C	1129.33	32666	29569	26126	23350	15648	12710		-	13.7
	12C	1343.61	32666	29569	26126	23350	15648	12710		-	13.7
	14C	1468.13	25385	21500	18990	17657	15258	12394		-	13.7
	18C	1746.69	25385	21500	18990	17657	15258	12394		-	13.6
20C	2099.39	18707	15813	13944	13339	12250	11780	-	13.5		

SERIES P

PL25

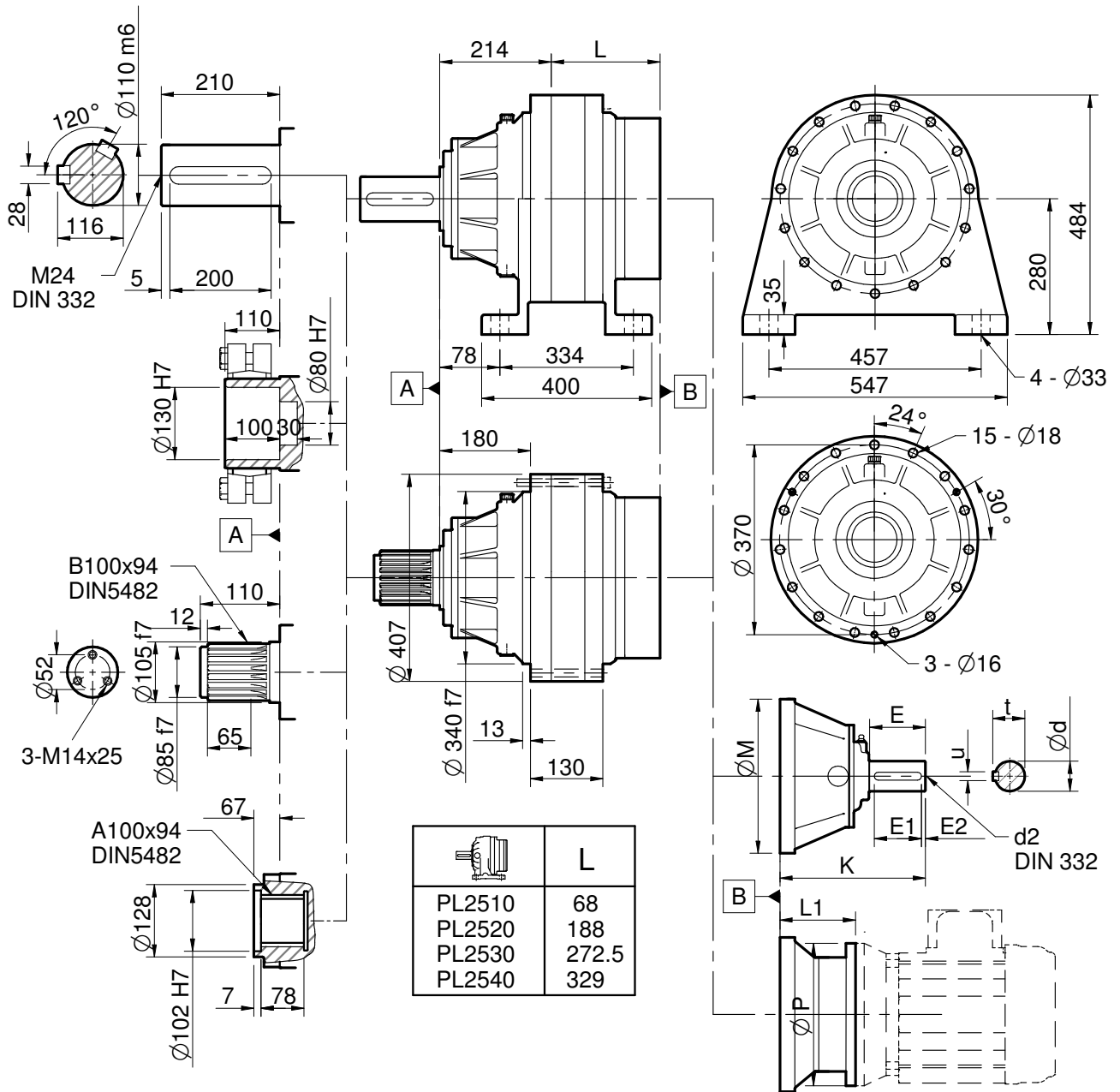

	PL2510	PL2520	PL2530	PL2540
K	373	259.5	228	180
M	407	291	240	196
d	90(m6)	65(m6)	48(k6)	38(k6)
d2	M24	M20	M16	M12
t	95	69	51.5	41
u	25	18	14	10
E	170	105	82	70
E1	160	90	70	60
E2	5	7.5	6	5

	PL2510		PL2520		PL2530		PL2540	
	L1	∅P	L1	∅P	L1	∅P	L1	∅P
63	-	-	-	-	-	-	62	140
71	-	-	-	-	-	-	66	160
80	-	-	-	-	-	-	80	200
90	-	-	-	-	-	-	80	200
100-112	-	-	-	-	-	-	91	250
132	-	-	-	-	140	300	108	300
160	-	-	172	350	156	350	-	-
180	-	-	172	350	156	350	-	-
200	189	400	174	400	-	-	-	-
225	216	450	-	-	-	-	-	-

SERIES P

PL40

Series P	Ratio iN	Ratio i	T2 (Nm) n2*h rating						n1 Max	Pt (kW) Type B	Pt (kW) Type F
			10,000	25,000	50,000	100,000	500,000	1,000,000			
PL4010	4.0	4.17	48787	45398	42760	38509	28637	23260	2000	-	64.2
	5.0	5.29	40870	34616	30595	28559	26276	22607		-	58.6
	6.3	6.21	33583	28415	25095	23985	22038	21170		-	55.3
PL4020	16.	16.17	48787	45398	42760	38509	28637	23260	2300	-	47.8
	20.	20.17	48787	45398	42760	38509	28637	23260		-	46.2
	25.	25.59	40870	34616	30595	28559	26276	22607		-	44.6
	28.	28.17	48787	45398	42760	38509	28637	23260		-	43.9
	32.	30.04	33583	28415	25095	23985	22038	21170		-	43.5
	36.	35.74	40870	34616	30595	28559	26276	22607		-	42.5
	45.	41.95	33583	28415	25095	23985	22038	21170		-	41.5
PL4030	56.	58.92	48787	45398	42760	38509	28637	23260	2800	-	28.1
	71.	70.58	48787	45398	42760	38509	28637	23260		-	27.9
	80.	74.73	40870	34616	30595	28559	26276	22607		-	27.8
	90.	90.98	48787	45398	42760	38509	28637	23260		-	27.5
	100	108.24	48787	45398	42760	38509	28637	23260		-	27.3
	112	113.48	48787	45398	42760	38509	28637	23260		-	27.2
	125	135.01	48787	45398	42760	38509	28637	23260		-	26.9
	140	143.93	40870	34616	30595	28559	26276	22607		-	26.8
	160	158.48	48787	45398	42760	38509	28637	23260		-	26.7
	180	188.55	48787	45398	42760	38509	28637	23260		-	26.5
	200	201.01	40870	34616	30595	28559	26276	22607		-	26.4
	250	239.15	40870	34616	30595	28559	26276	22607		-	26.2
	280	280.72	33583	28415	25095	23985	22038	21170		-	26.0
PL4040	225	229.1	48787	45398	42760	38509	28637	23260	3500	-	20.3
	280	277.8	48787	45398	42760	38509	28637	23260		-	19.3
	315	332.7	48787	45398	42760	38509	28637	23260		-	18.4
	360	365.3	48787	45398	42760	38509	28637	23260		-	18.3
	400	441.9	48787	45398	42760	38509	28637	23260		-	18.2
	450	455.6	48787	45398	42760	38509	28637	23260		-	18.2
	500	529.3	48787	45398	42760	38509	28637	23260		-	18.1
	560	564.1	48787	45398	42760	38509	28637	23260		-	18.1
	630	682.3	48787	45398	42760	38509	28637	23260		-	18.0
	710	715.5	40870	34616	30595	28559	26276	22607		-	18.0
	800	851.1	48787	45398	42760	38509	28637	23260		-	17.9
	900	865.5	40870	34616	30595	28559	26276	22607		-	17.9
	10C	1012.6	48787	45398	42760	38509	28637	23260		-	17.8
	12C	1188.6	48787	45398	42760	38509	28637	23260		-	17.7
	14C	1414.1	48787	45398	42760	38509	28637	23260		-	17.6
	18C	1793.6	40870	34616	30595	28559	26276	22607		-	17.5
	20C	2105.4	33583	28415	25095	23985	22038	21170		-	17.5

SERIES P

PL40

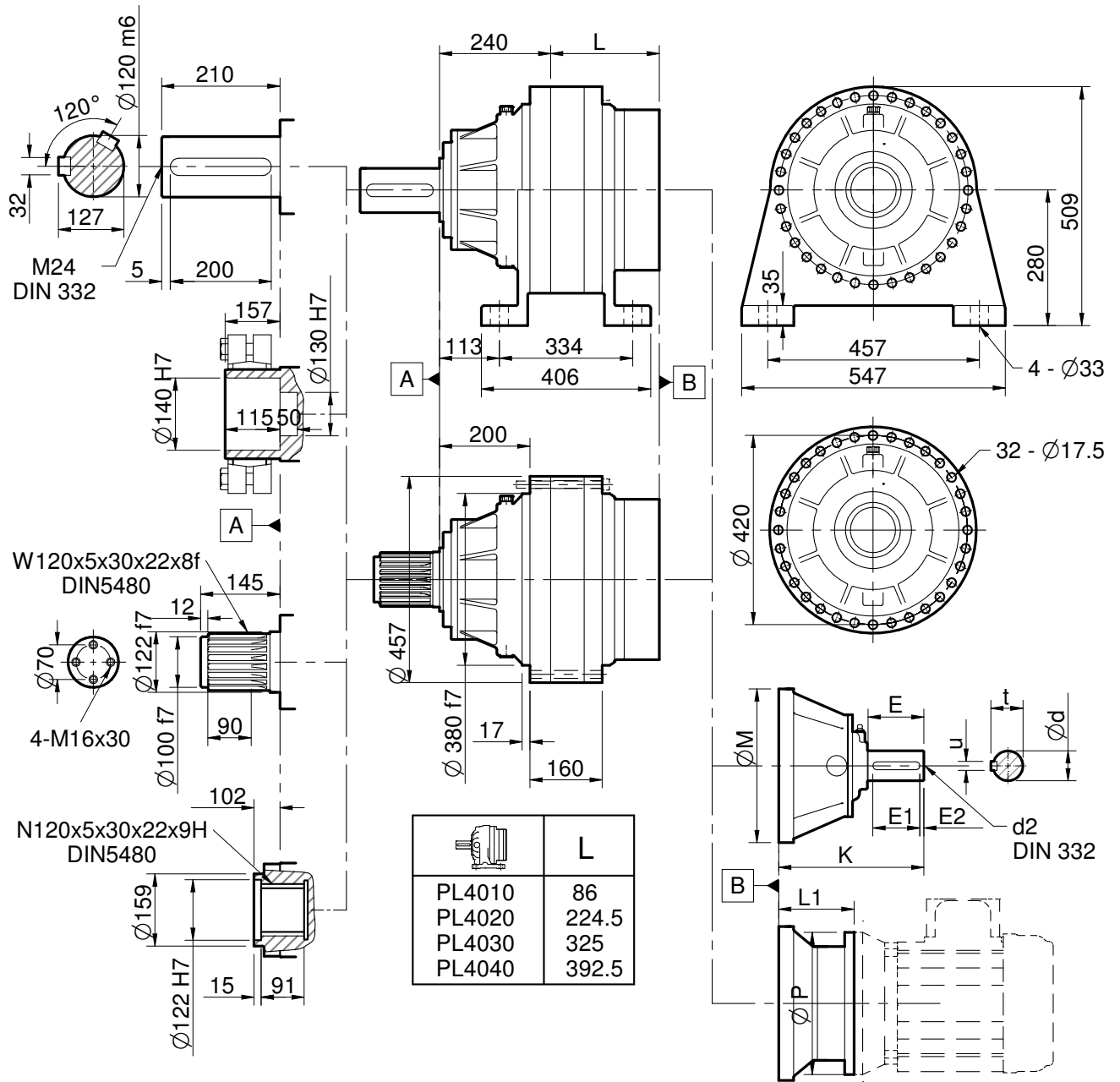

	PL4010	PL4020	PL4030	PL4040
K	410	313	228	180
M	457	355	240	196
d	100(m6)	80(m6)	48(k6)	38(k6)
d2	M24	M20	M16	M12
t	106	85	51.5	41
u	28	22	14	10
E	190	130	82	70
E1	180	110	70	60
E2	5	10	6	5

	PL4020		PL4030		PL4040	
	L1	ØP	L1	ØP	L1	ØP
63	-	-	-	-	62	140
71	-	-	-	-	66	160
80	-	-	-	-	80	200
90	-	-	-	-	80	200
100-112	-	-	-	-	91	250
132	-	-	140	300	108	300
160	-	-	156	350	-	-
180	-	-	156	350	-	-
200	176	400	-	-	-	-
225	204	450	-	-	-	-

SERIES P

PL65

Series P	Ratio iN	Ratio i	T2 (Nm) n2*h rating						n1 Max	Pt (kW) Type B	Pt (kW) Type F
			10,000	25,000	50,000	100,000	500,000	1,000,000			
PL6510	4.0	4.17	84700	78850	73150	68250	57443	46658	2000	-	89.6
	5.0	4.84	80100	67950	60150	57400	52930	45817		-	84.5
	6.3	5.87	60700	51460	46370	44680	41080	39480		-	78.7
PL6520	16.	16.70	84700	78850	73150	68250	57443	46658	2000	-	55.0
	18.	19.37	80100	67950	60150	57400	52930	45817		-	55.3
	20.	21.70	84700	78850	73150	68250	57443	46658		-	55.5
	22.	25.18	80100	67950	60150	57400	52930	45817		-	55.6
	28.	26.09	84700	78850	73150	68250	57443	46658		-	55.7
	32.	30.26	80100	67950	60150	57400	52930	45817		-	55.9
	40.	36.67	60700	51460	46370	44680	41080	39480		-	56.1
PL6530	56.	60.82	84700	78850	73150	68250	57443	46658	2500	-	38.8
	63.	70.56	80100	67950	60150	57400	52930	45817		-	38.4
	71.	72.85	84700	78850	73150	68250	57443	46658		-	38.4
	80.	84.52	80100	67950	60150	57400	52930	45817		-	38.1
	90.	93.91	84700	78850	73150	68250	57443	46658		-	37.9
	100	111.73	84700	78850	73150	68250	57443	46658		-	37.5
	112	122.09	84700	78850	73150	68250	57443	46658		-	37.3
	125	129.62	80100	67950	60150	57400	52930	45817		-	37.2
	140	145.25	84700	78850	73150	68250	57443	46658		-	37.0
	160	146.74	84700	78850	73150	68250	57443	46658		-	37.0
	180	188.55	84700	78850	73150	68250	57443	46658		-	36.5
	225	218.73	80100	67950	60150	57400	52930	45817		-	36.2
	250	265.02	60700	51460	46370	44680	41080	39480		-	35.9
PL6540	225	221.6	84700	78850	73150	68250	57443	46658	2800	-	27.6
	280	265.4	84700	78850	73150	68250	57443	46658		-	26.1
	315	317.9	84700	78850	73150	68250	57443	46658		-	25.9
	360	342.1	84700	78850	73150	68250	57443	46658		-	25.9
	400	407.0	84700	78850	73150	68250	57443	46658		-	25.7
	450	444.7	84700	78850	73150	68250	57443	46658		-	25.7
	500	487.6	84700	78850	73150	68250	57443	46658		-	25.6
	560	528.3	84700	78850	73150	68250	57443	46658		-	25.6
	630	628.5	84700	78850	73150	68250	57443	46658		-	25.4
	710	686.7	84700	78850	73150	68250	57443	46658		-	25.4
	800	817.0	84700	78850	73150	68250	57443	46658		-	25.2
	10C	972.1	84700	78850	73150	68250	57443	46658		-	25.1
	12C	1168.4	84700	78850	73150	68250	57443	46658		-	25.0
	14C	1355.4	80100	67950	60150	57400	52930	45817		-	24.9
	16C	1642.2	60700	51460	46370	44680	41080	39480		-	24.8

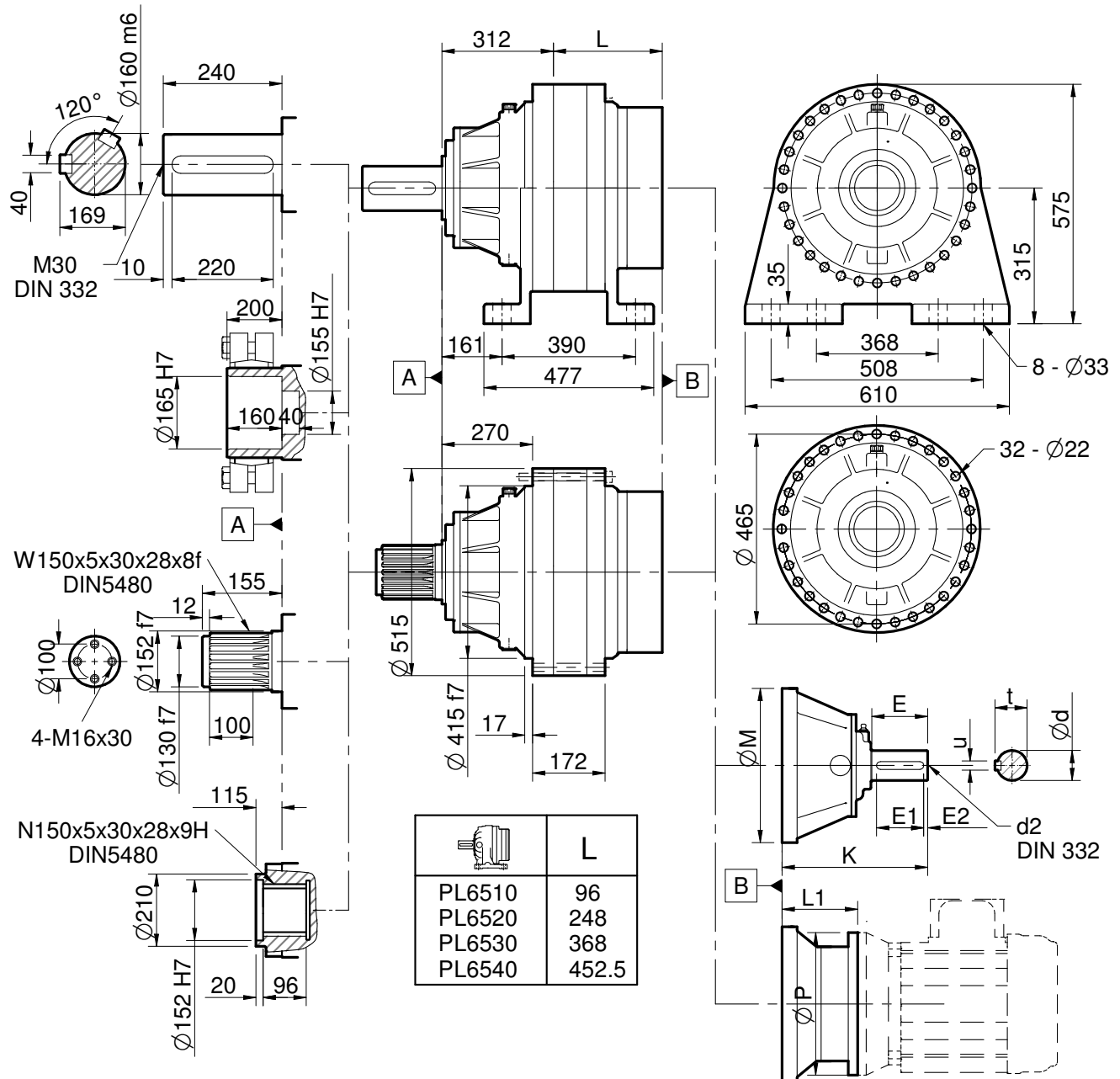

	PL6510	PL6520	PL6530	PL6540
K	477	373	259.5	228
M	515	407	291	240
d	110(m6)	90(m6)	65(k6)	48(k6)
d2	M24	M24	M20	M16
t	116	95	69	51.5
u	28	25	18	14
E	210	170	105	82
E1	200	160	90	70
E2	5	5	7.5	6

	PL6520		PL6530		PL6540	
	L1	ØP	L1	ØP	L1	ØP
132	-	-	-	-	140	300
160	-	-	172	350	156	350
180	-	-	172	350	156	350
200	189	400	174	400	-	-
225	216	450	-	-	-	-

SERIES P

PL MOTORISED RATINGS

	N2	Ratio <i>i</i>	M2 (NM)	fm	FR2 (N)	Unit Designation	Motor Frame	PT(kW) Type B	PT (kW) Type F	
0.12 kW 4 - Pole	5.0	288.30	219	3.15	15000	PL0130280. - M --- .12 A	63	6.4	5.9	
	4.2	348.75	265	2.64	15000	PL0130360. - M --- .12 A	63	6.4	5.8	
	3.4	421.88	320	1.63	15000	PL0130400. - M --- .12 A	63	6.3	5.8	
	5.2	277.26	208	5.83	15000	PL0140280. - M --- .12 A	63	5.6	5.2	
	4.3	336.11	252	4.87	15000	PL0140315 - M --- .12 A	63	5.5	5.1	
	4.0	364.64	274	4.51	15000	PL0140360 - M --- .12 A	63	5.3	4.9	
	3.3	441.10	331	3.77	15000	PL0140450 - M --- .12 A	63	5.1	4.7	
	2.7	534.72	401	3.15	15000	PL0140500 - M --- .12 A	63	4.7	4.3	
	2.5	581.35	436	2.91	15000	PL0140560 - M --- .12 A	63	4.7	4.3	
	2.2	648.21	487	2.63	15000	PL0140630 - M --- .12 A	63	4.7	4.3	
	2.1	703.24	528	2.44	15000	PL0140710 - M --- .12 A	63	4.7	4.3	
	1.7	850.69	639	2.04	15000	PL0140800 - M --- .12 A	63	4.6	4.3	
	1.6	926.83	696	1.88	15000	PL0140900 - M --- .12 A	63	4.6	4.3	
	1.4	1031.25	774	1.70	15000	PL014010C - M --- .12 A	63	4.6	4.3	
	1.3	1121.17	842	1.57	15000	PL014011C - M --- .12 A	63	4.6	4.2	
	1.1	1356.25	1018	1.32	15000	PL014014C - M --- .12 A	63	4.6	4.2	
	0.88	1640.63	1232	1.10	15000	PL014016C - M --- .12 A	63	4.6	4.2	
	1.7	850.69	639	3.77	15000	PL0240800 - M --- .12 A	63	4.8	4.4	
	1.6	926.83	696	3.47	15000	PL0240900 - M --- .12 A	63	4.8	4.4	
	1.4	1031.25	774	3.14	15000	PL024010C - M --- .12 A	63	4.7	4.4	
	1.3	1121.17	842	2.91	15000	PL024011C - M --- .12 A	63	4.7	4.4	
	1.1	1356.25	1018	2.43	15000	PL024014C - M --- .12 A	63	4.7	4.4	
	0.88	1640.63	1232	2.03	15000	PL024016C - M --- .12 A	63	4.7	4.3	
	0.81	1787.46	1342	1.06	15000	PL024018C - M --- .12 A	63	4.7	4.3	
	0.73	1988.84	1493	1.38	15000	PL024020C - M --- .12 A	63	4.7	4.3	
	0.67	2162.25	1623	0.89	15000	PL024022C - M --- .12 A	63	4.6	4.3	
	0.93	1536.83	1170	3.54	44500	PL034012C - M --- .12 A	63	7.1	6.8	
	0.88	1621.69	1235	1.99	44500	PL034014C - M --- .12 A	63	7.1	6.8	
	0.78	1840.91	1402	2.54	44500	PL034016C - M --- .12 A	63	7.0	6.8	
	0.73	1961.72	1494	1.66	44500	PL034018C - M --- .12 A	63	7.0	6.8	
	0.60	2373.05	1807	1.39	44500	PL034020C - M --- .12 A	63	7.0	6.8	
	0.51	2823.32	2149	0.88	44500	PL034022C - M --- .12 A	63	7.0	6.7	
	0.88	1621.69	1235	3.06	44500	PL054016C - M --- .12 A	63	7.4	7.1	
	0.78	1840.91	1402	3.91	44500	PL054018C - M --- .12 A	63	7.3	7.1	
	0.73	1961.72	1494	2.56	44500	PL054020C - M --- .12 A	63	7.3	7.1	
	0.60	2373.05	1807	2.14	44500	PL054022C - M --- .12 A	63	7.3	7.0	
	0.51	2823.32	2149	1.35	44500	PL054025C - M --- .12 A	63	7.3	7.0	
	0.68	2117.49	1612	4.16	52000	PL084020C - M --- .12 A	63	10.4	9.7	
	0.57	2519.27	1918	2.99	52000	PL084025C - M --- .12 A	63	10.3	9.7	
	0.57	2519.27	1918	3.99	52000	PL124025C - M --- .12 A	63	11.5	10.8	
	0.18 kW 4 - Pole	5.5	265.18	302	3.25	15000	PL0130250 - M --- .18 A	63	6.5	5.9
		5.0	288.30	328	2.10	15000	PL0130280 - M --- .18 A	63	6.4	5.9
		4.2	348.75	397	1.76	15000	PL0130360 - M --- .18 A	63	6.4	5.8
		3.4	421.88	480	1.08	15000	PL0130400 - M --- .18 A	63	6.3	5.8
		5.2	277.26	312	3.89	15000	PL0140280 - M --- .18 A	63	5.6	5.2
		4.3	336.11	379	3.24	15000	PL0140315 - M --- .18 A	63	5.5	5.1
		4.0	364.64	411	3.01	15000	PL0140360 - M --- .18 A	63	5.3	4.9
3.3		441.10	497	2.51	15000	PL0140450 - M --- .18 A	63	5.1	4.7	
2.7		534.72	602	2.10	15000	PL0140500 - M --- .18 A	63	4.7	4.3	
2.5		581.35	655	1.94	15000	PL0140560 - M --- .18 A	63	4.7	4.3	
2.2		648.21	730	1.75	15000	PL0140630 - M --- .18 A	63	4.7	4.3	
2.1		703.24	792	1.62	15000	PL0140710 - M --- .18 A	63	4.7	4.3	
1.7		850.69	958	1.36	15000	PL0140800 - M --- .18 A	63	4.6	4.3	
1.6		926.83	1044	1.25	15000	PL0140900 - M --- .18 A	63	4.6	4.3	
1.4		1031.25	1161	1.13	15000	PL014010C - M --- .18 A	63	4.6	4.3	
1.3		1121.17	1263	1.05	15000	PL014011C - M --- .18 A	63	4.6	4.2	
1.1		1356.25	1527	0.88	15000	PL014014C - M --- .18 A	63	4.6	4.2	
5.0		288.30	328	3.88	15000	PL0230280 - M --- .18 A	63	6.6	6.1	
4.2		348.75	397	3.25	15000	PL0230360 - M --- .18 A	63	6.6	6.0	
3.4		421.88	480	2.00	15000	PL0230400 - M --- .18 A	63	6.5	6.0	
2.7		534.72	602	3.88	15000	PL0240500 - M --- .18 A	63	5.2	4.8	
2.5		581.35	655	3.59	15000	PL0240560 - M --- .18 A	63	4.8	4.4	
2.2		648.21	730	3.24	15000	PL0240630 - M --- .18 A	63	4.8	4.4	
2.1		703.24	792	3.00	15000	PL0240710 - M --- .18 A	63	4.8	4.4	
1.7		850.69	958	2.51	15000	PL0240800 - M --- .18 A	63	4.8	4.4	
1.6		926.83	1044	2.32	15000	PL0240900 - M --- .18 A	63	4.8	4.4	
1.4		1031.25	1161	2.10	15000	PL024010C - M --- .18 A	63	4.7	4.4	
1.3		1121.17	1263	1.94	15000	PL024011C - M --- .18 A	63	4.7	4.4	
1.1		1356.25	1527	1.62	15000	PL024014C - M --- .18 A	63	4.7	4.4	
0.88		1640.63	1848	1.36	15000	PL024016C - M --- .18 A	63	4.7	4.3	
1.6		868.19	991	4.03	44500	PL0340900 - M --- .18 A	63	7.2	6.9	
1.5		966.01	1103	3.65	44500	PL034010C - M --- .18 A	63	7.1	6.9	
1.4		1050.24	1199	3.37	44500	PL034011C - M --- .18 A	63	7.1	6.9	
1.1		1270.45	1451	2.82	44500	PL034012C - M --- .18 A	63	7.1	6.8	
0.93		1536.83	1755	2.36	44500	PL034014C - M --- .18 A	63	7.1	6.8	

PL MOTORISED RATINGS

	N2	Ratio <i>i</i>	M2 (NM)	fm	FR2 (N)	Unit Designation	Motor Frame	PT(kW) Type B	PT (kW) Type F
0.18 kW 4 - Pole	0.88	1621.69	1852	1.33	44500	PL034016C - M --- .18 A	63	7.0	6.8
	0.78	1840.91	2102	1.69	44500	PL034018C - M --- .18 A	63	7.0	6.8
	0.73	1961.72	2240	1.11	44500	PL034020C - M --- .18 A	63	7.0	6.8
	0.60	2373.05	2710	0.93	44500	PL034022C - M --- .18 A	63	7.0	6.7
	0.93	1536.83	1755	3.63	44500	PL054014C - M --- .18 A	63	7.4	7.1
	0.88	1621.69	1852	2.04	44500	PL054016C - M --- .18 A	63	7.4	7.1
	0.78	1840.91	2102	2.60	44500	PL054018C - M --- .18 A	63	7.3	7.1
	0.73	1961.72	2240	1.71	44500	PL054020C - M --- .18 A	63	7.3	7.1
	0.60	2373.05	2710	1.43	44500	PL054022C - M --- .18 A	63	7.3	7.0
	0.51	2823.32	3224	0.90	44500	PL054025C - M --- .18 A	63	7.3	7.0
	0.80	1779.79	2033	3.27	52000	PL084018C - M --- .18 A	63	10.4	9.8
	0.68	2117.49	2418	2.77	52000	PL084020C - M --- .18 A	63	10.4	9.7
	0.57	2519.27	2877	1.99	52000	PL084025C - M --- .18 A	63	10.3	9.7
	0.68	2117.49	2418	3.70	52000	PL124020C - M --- .18 A	63	10.9	10.3
	0.57	2519.27	2877	2.66	52000	PL124025C - M --- .18 A	63	10.9	10.3
	0.68	2100.55	2399	4.14	54000	PL164020C - M --- .18 A	63	18.6	13.0
0.56	2540.99	2902	3.47	54000	PL164025C - M --- .18 A	63	18.5	12.9	
0.25 kW 4 - Pole	8.7	166.68	263	3.62	15000	PL0130160 - M --- .25 A	71	6.6	6.0
	8.0	180.83	286	4.13	15000	PL0130180 - M --- .25 A	71	6.6	6.0
	6.6	218.75	346	3.46	15000	PL0130225 - M --- .25 A	71	6.5	6.0
	5.5	265.18	419	2.34	15000	PL0130250 - M --- .25 A	71	6.5	5.9
	5.0	288.30	456	1.51	15000	PL0130280 - M --- .25 A	71	6.4	5.9
	4.2	348.75	551	1.27	15000	PL0130360 - M --- .25 A	71	6.4	5.8
	5.2	277.26	434	2.80	15000	PL0140280 - M --- .25 A	71	5.6	5.2
	4.3	336.11	526	2.34	15000	PL0140315 - M --- .25 A	71	5.5	5.1
	4.0	364.64	570	2.16	15000	PL0140360 - M --- .25 A	71	5.3	4.9
	3.3	441.10	690	1.81	15000	PL0140450 - M --- .25 A	71	5.1	4.7
	2.7	534.72	836	1.51	15000	PL0140500 - M --- .25 A	71	4.7	4.3
	2.5	581.35	909	1.40	15000	PL0140560 - M --- .25 A	71	4.7	4.3
	2.2	648.21	1014	1.26	15000	PL0140630 - M --- .25 A	71	4.7	4.3
	2.1	703.24	1100	1.17	15000	PL0140710 - M --- .25 A	71	4.7	4.3
	1.7	850.69	1331	0.98	15000	PL0140800 - M --- .25 A	71	4.6	4.3
	1.6	926.83	1450	0.90	15000	PL0140900 - M --- .25 A	71	4.6	4.3
	1.4	1031.25	1613	0.82	15000	PL014010C - M --- .25 A	71	4.6	4.3
	5.5	265.18	419	4.32	15000	PL0230250 - M --- .25 A	71	6.6	6.1
	5.0	288.30	456	2.79	15000	PL0230280 - M --- .25 A	71	6.6	6.1
	4.2	348.75	551	2.34	15000	PL0230360 - M --- .25 A	71	6.6	6.0
	3.4	421.88	667	1.44	15000	PL0230400 - M --- .25 A	71	6.5	6.0
	5.2	277.26	434	5.17	15000	PL0240280 - M --- .25 A	71	5.7	5.3
	4.3	336.11	526	4.31	15000	PL0240315 - M --- .25 A	71	5.7	5.2
	4.0	364.64	570	4.00	15000	PL0240360 - M --- .25 A	71	5.4	5.0
	3.3	441.10	690	3.34	15000	PL0240450 - M --- .25 A	71	5.2	4.8
	2.7	534.72	836	2.79	15000	PL0240500 - M --- .25 A	71	4.8	4.4
	2.5	581.35	909	2.58	15000	PL0240560 - M --- .25 A	71	4.8	4.4
	2.2	648.21	1014	2.33	15000	PL0240630 - M --- .25 A	71	4.8	4.4
	2.1	703.24	1100	2.16	15000	PL0240710 - M --- .25 A	71	4.8	4.4
	1.7	850.69	1331	1.81	15000	PL0240800 - M --- .25 A	71	4.8	4.4
	1.6	926.83	1450	1.67	15000	PL0240900 - M --- .25 A	71	4.7	4.4
	1.4	1031.25	1613	1.51	15000	PL024010C - M --- .25 A	71	4.7	4.4
	1.3	1121.17	1754	1.40	15000	PL024011C - M --- .25 A	71	4.7	4.4
	1.1	1356.25	2121	1.17	15000	PL024014C - M --- .25 A	71	4.7	4.3
	0.88	1640.63	2566	0.98	15000	PL024016C - M --- .25 A	71	4.7	4.3
	2.2	658.75	1045	3.76	44500	PL0340710 - M --- .25 A	71	7.2	6.9
	1.8	796.88	1264	3.15	44500	PL0340800 - M --- .25 A	71	7.2	6.9
	1.6	868.19	1377	2.90	44500	PL0340900 - M --- .25 A	71	7.2	6.9
	1.5	966.01	1532	2.63	44500	PL034010C - M --- .25 A	71	7.1	6.9
	1.4	1050.24	1666	2.43	44500	PL034011C - M --- .25 A	71	7.1	6.9
	1.1	1270.45	2015	2.03	44500	PL034012C - M --- .25 A	71	7.1	6.8
	0.9	1536.83	2438	1.70	44500	PL034014C - M --- .25 A	71	7.1	6.8
	0.9	1621.69	2572	0.95	44500	PL034016C - M --- .25 A	71	7.0	6.8
	0.8	1840.91	2920	1.22	44500	PL034018C - M --- .25 A	71	7.0	6.8
	0.7	1961.72	3111	0.80	44500	PL034020C - M --- .25 A	71	7.0	6.8
	1.5	966.01	1532	4.04	44500	PL054010C - M --- .25 A	71	7.5	7.3
	1.4	1050.24	1666	3.74	44500	PL054011C - M --- .25 A	71	7.5	7.2
	1.1	1270.45	2015	3.13	44500	PL054012C - M --- .25 A	71	7.5	7.2
0.93	1536.83	2438	2.62	44500	PL054014C - M --- .25 A	71	7.5	7.2	
0.88	1621.69	2572	1.47	44500	PL054016C - M --- .25 A	71	7.4	7.2	
0.78	1840.91	2920	1.88	44500	PL054018C - M --- .25 A	71	7.4	7.2	
0.73	1961.72	3111	1.23	44500	PL054020C - M --- .25 A	71	7.4	7.1	
0.60	2373.05	3764	1.03	44500	PL054022C - M --- .25 A	71	7.4	7.1	
0.97	1471.29	2334	2.81	52000	PL084014C - M --- .25 A	71	10.5	9.8	
0.87	1642.66	2605	3.68	52000	PL084016C - M --- .25 A	71	10.4	9.8	
0.80	1779.79	2823	2.35	52000	PL084018C - M --- .25 A	71	10.4	9.8	
0.68	2117.49	3359	2.00	52000	PL084020C - M --- .25 A	71	10.4	9.7	
0.57	2519.27	3996	1.44	52000	PL084025C - M --- .25 A	71	10.3	9.7	

SERIES P

PL MOTORISED RATINGS

	N2	Ratio <i>i</i>	M2 (NM)	fm	FR2 (N)	Unit Designation	Motor Frame	PT(kW) Type B	PT (κW) Type F
0.25 kW 4 - Pole	0.80	1779.79	2823	3.14	52000	PL124018C -M --- .25 A	71	11.0	10.4
	0.68	2117.49	3359	2.66	52000	PL124020C -M --- .25 A	71	10.9	10.3
	0.57	2519.27	3996	1.91	52000	PL124025C -M --- .25 A	71	10.9	10.3
	0.68	2100.55	3332	2.98	54000	PL164020C -M --- .25 A	71	18.6	13.0
	0.56	2540.99	4030	2.50	54000	PL164025C -M --- .25 A	71	18.5	12.9
0.37 kW 4 - Pole	13.8	104.77	245	3.77	15000	PL0130100 -M --- .37 A	71	6.7	6.2
	12.8	113.43	265	4.32	15000	PL0130112 -M --- .37 A	71	6.7	6.2
	10.5	137.50	322	3.61	15000	PL0130125 -M --- .37 A	71	6.7	6.1
	9.7	149.49	350	3.34	15000	PL0130140 -M --- .37 A	71	6.6	6.1
	8.7	166.68	390	2.44	15000	PL0130160 -M --- .37 A	71	6.6	6.0
	8.0	180.83	423	2.79	15000	PL0130180 -M --- .37 A	71	6.6	6.0
	6.6	218.75	512	2.34	15000	PL0130225 -M --- .37 A	71	6.5	6.0
	5.5	265.18	620	1.58	15000	PL0130250 -M --- .37 A	71	6.5	5.9
	5.0	288.30	674	1.02	15000	PL0130280 -M --- .37 A	71	6.4	5.9
	4.2	348.75	816	0.85	15000	PL0130360 -M --- .37 A	71	6.4	5.8
	5.2	277.26	649	1.87	15000	PL0140280 -M --- .37 A	71	5.6	5.2
	4.3	336.11	786	1.56	15000	PL0140315 -M --- .37 A	71	5.5	5.1
	4.0	364.64	853	1.45	15000	PL0140360 -M --- .37 A	71	5.3	4.9
	3.3	441.10	1032	1.21	15000	PL0140450 -M --- .37 A	71	5.1	4.7
	2.7	534.72	1251	1.01	15000	PL0140500 -M --- .37 A	71	4.7	4.3
	2.5	581.35	1360	0.93	15000	PL0140560 -M --- .37 A	71	4.7	4.3
	2.2	648.21	1516	0.84	15000	PL0140630 -M --- .37 A	71	4.7	4.3
	6.6	218.75	512	4.31	15000	PL0230225 -M --- .37 A	71	6.7	6.1
	5.5	265.18	620	2.92	15000	PL0230250 -M --- .37 A	71	6.6	6.1
	5.0	288.30	674	1.89	15000	PL0230280 -M --- .37 A	71	6.6	6.1
	4.2	348.75	816	1.58	15000	PL0230360 -M --- .37 A	71	6.6	6.0
	3.4	421.88	987	0.97	15000	PL0230400 -M --- .37 A	71	6.5	6.0
	5.2	277.26	642	3.49	15000	PL0240280 -M --- .37 A	71	5.7	5.3
	4.3	336.11	778	2.91	15000	PL0240315 -M --- .37 A	71	5.7	5.2
	4.0	364.64	844	2.70	15000	PL0240360 -M --- .37 A	71	5.4	5.0
	3.3	441.10	1021	2.26	15000	PL0240450 -M --- .37 A	71	5.2	4.8
	2.7	534.72	1238	1.89	15000	PL0240500 -M --- .37 A	71	4.8	4.4
	2.5	581.35	1346	1.74	15000	PL0240560 -M --- .37 A	71	4.8	4.4
	2.2	648.21	1501	1.58	15000	PL0240630 -M --- .37 A	71	4.8	4.4
	2.1	703.24	1628	1.46	15000	PL0240710 -M --- .37 A	71	4.8	4.4
	1.7	850.69	1969	1.22	15000	PL0240800 -M --- .37 A	71	4.8	4.4
	1.6	926.83	2146	1.13	15000	PL0240900 -M --- .37 A	71	4.7	4.4
	1.4	1031.25	2387	1.02	15000	PL024010C -M --- .37 A	71	4.7	4.4
	1.3	1121.17	2596	0.94	15000	PL024011C -M --- .37 A	71	4.7	4.4
	5.5	261.56	620	3.53	44500	PL0330280 -M --- .37 A	71	9.5	9.1
	4.5	316.41	751	2.95	44500	PL0330315 -M --- .37 A	71	9.4	9.0
	3.8	376.44	893	1.87	44500	PL0330360 -M --- .37 A	71	9.3	9.0
	3.5	413.19	970	3.93	44500	PL0340400 -M --- .37 A	71	7.3	7.0
	2.9	500.89	1176	3.28	44500	PL0340500 -M --- .37 A	71	7.3	7.0
	2.6	544.57	1278	3.04	44500	PL0340560 -M --- .37 A	71	7.2	7.0
	2.4	607.20	1425	2.74	44500	PL0340630 -M --- .37 A	71	7.2	7.0
	2.2	658.75	1546	2.54	44500	PL0340710 -M --- .37 A	71	7.2	6.9
	1.8	796.88	1871	2.13	44500	PL0340800 -M --- .37 A	71	7.2	6.9
	1.6	868.19	2038	1.96	44500	PL0340900 -M --- .37 A	71	7.2	6.9
	1.5	966.01	2268	1.77	44500	PL034010C -M --- .37 A	71	7.1	6.9
	1.4	1050.24	2465	1.64	44500	PL034011C -M --- .37 A	71	7.1	6.9
	1.1	1270.45	2982	1.37	44500	PL034012C -M --- .37 A	71	7.1	6.8
	0.93	1536.83	3608	1.15	44500	PL034014C -M --- .37 A	71	7.1	6.8
	0.88	1621.69	3807	0.65	44500	PL034016C -M --- .37 A	71	7.0	6.8
	0.78	1840.91	4321	0.82	44500	PL034018C -M --- .37 A	71	7.0	6.8
3.8	376.44	893	2.87	44500	PL0530360 -M --- .37 A	71	9.8	9.4	
2.4	607.20	1425	4.22	44500	PL0540630 -M --- .37 A	71	7.6	7.3	
2.2	658.75	1546	3.91	44500	PL0540710 -M --- .37 A	71	7.5	7.3	
1.8	796.88	1871	3.27	44500	PL0540800 -M --- .37 A	71	7.5	7.2	
1.6	868.19	2038	3.02	44500	PL0540900 -M --- .37 A	71	7.5	7.2	
1.5	966.01	2268	2.73	44500	PL054010C -M --- .37 A	71	7.5	7.2	
1.4	1050.24	2465	2.52	44500	PL054011C -M --- .37 A	71	7.4	7.2	
1.1	1270.45	2982	2.11	44500	PL054012C -M --- .37 A	71	7.4	7.2	
0.93	1536.83	3608	1.77	44500	PL054014C -M --- .37 A	71	7.4	7.1	
0.88	1621.69	3807	0.99	44500	PL054016C -M --- .37 A	71	7.4	7.1	
0.78	1840.91	4321	1.27	44500	PL054018C -M --- .37 A	71	7.3	7.1	
0.73	1961.72	4605	0.83	44500	PL054020C -M --- .37 A	71	7.3	7.1	
1.2	1152.62	2706	4.03	52000	PL084011C -M --- .37 A	71	10.5	9.9	
1.0	1371.33	3219	3.42	52000	PL084012C -M --- .37 A	71	10.5	9.8	
1.0	1471.29	3454	1.90	52000	PL084014C -M --- .37 A	71	10.5	9.8	
0.87	1642.66	3856	2.49	52000	PL084016C -M --- .37 A	71	10.4	9.8	
0.80	1779.79	4178	1.59	52000	PL084018C -M --- .37 A	71	10.4	9.8	
0.68	2117.49	4971	1.35	52000	PL084020C -M --- .37 A	71	10.4	9.7	
0.57	2519.27	5914	0.97	52000	PL084025C -M --- .37 A	71	10.3	9.7	

SERIES P

PL MOTORISED RATINGS

	N2	Ratio <i>i</i>	M2 (NM)	fm	FR2 (N)	Unit Designation	Motor Frame	PT(kW) Type B	PT (kW) Type F
0.37 kW 4 - Pole	1.0	1371.33	3219	4.24	52000	PL124012C - M --- .37 A	71	11.1	10.4
	0.97	1471.29	3454	2.53	52000	PL124014C - M --- .37 A	71	11.1	10.4
	0.87	1642.66	3856	3.17	52000	PL124016C - M --- .37 A	71	11.0	10.4
	0.80	1779.79	4178	2.12	52000	PL124018C - M --- .37 A	71	11.0	10.4
	0.68	2117.49	4971	1.80	52000	PL124020C - M --- .37 A	71	10.9	10.3
	0.57	2519.27	5914	1.29	52000	PL124025C - M --- .37 A	71	10.9	10.3
	0.79	1819.47	4271	3.72	54000	PL164018C - M --- .37 A	71	18.7	13.0
	0.68	2100.55	4931	2.02	54000	PL164020C - M --- .37 A	71	18.6	13.0
	0.56	2540.99	5965	1.69	54000	PL164025C - M --- .37 A	71	18.5	12.9
	0.68	2099.39	4928	3.36	80000	PL254020C - M --- 0.37 A	71	-	13.5
0.55 kW 4 - Pole	16.8	86.43	301	3.75	15000	PL013080. - M --- .55 A	80	6.8	6.2
	15.5	93.77	326	3.48	15000	PL013090. - M --- .55 A	80	6.8	6.2
	13.8	104.77	364	2.54	15000	PL0130100 - M --- .55 A	80	6.7	6.2
	12.8	113.43	394	2.91	15000	PL0130112 - M --- .55 A	80	6.7	6.2
	10.5	137.50	478	2.43	15000	PL0130125 - M --- .55 A	80	6.7	6.1
	9.7	149.49	520	2.24	15000	PL0130140 - M --- .55 A	80	6.6	6.1
	8.7	166.68	580	1.64	15000	PL0130160 - M --- .55 A	80	6.6	6.0
	8.0	180.83	629	1.88	15000	PL0130180 - M --- .55 A	80	6.6	6.0
	6.6	218.75	761	1.57	15000	PL0130225 - M --- .55 A	80	6.5	6.0
	5.5	265.18	922	1.06	15000	PL0130250 - M --- .55 A	80	6.5	5.9
	5.2	277.26	964	1.26	15000	PL0140280 - M --- .55 A	80	5.6	5.2
	4.3	336.11	1169	1.05	15000	PL0140315 - M --- .55 A	80	5.5	5.1
	4.0	364.64	1268	0.97	15000	PL0140360 - M --- .55 A	80	5.3	4.9
	3.3	441.10	1534	0.81	15000	PL0140450 - M --- .55 A	80	5.1	4.7
	8.7	166.68	580	3.03	15000	PL0230160 - M --- .55 A	80	6.8	6.2
	8.0	180.83	629	3.47	15000	PL0230180 - M --- .55 A	80	6.8	6.2
	6.6	218.75	761	2.90	15000	PL0230225 - M --- .55 A	80	6.7	6.1
	5.5	265.18	922	1.96	15000	PL0230250 - M --- .55 A	80	6.6	6.1
	5.0	288.30	1003	1.27	15000	PL0230280 - M --- .55 A	80	6.6	6.1
	4.2	348.75	1213	1.06	15000	PL0230360 - M --- .55 A	80	6.6	6.0
	5.2	277.26	954	2.35	15000	PL0240280 - M --- .55 A	80	5.7	5.3
	4.3	336.11	1157	1.96	15000	PL0240315 - M --- .55 A	80	5.7	5.2
	4.0	364.64	1255	1.82	15000	PL0240360 - M --- .55 A	80	5.4	5.0
	3.3	441.10	1518	1.52	15000	PL0240450 - M --- .55 A	80	5.2	4.8
	2.7	534.72	1840	1.27	15000	PL0240500 - M --- .55 A	80	4.8	4.4
	2.5	581.35	2001	1.17	15000	PL0240560 - M --- .55 A	80	4.8	4.4
	2.2	648.21	2231	1.06	15000	PL0240630 - M --- .55 A	80	4.8	4.4
	2.1	703.24	2420	0.98	15000	PL0240710 - M --- .55 A	80	4.8	4.4
	1.7	850.69	2927	0.82	15000	PL0240800 - M --- .55 A	80	4.8	4.4
	5.8	245.45	866	3.62	44500	PL0330250 - M --- .55 A	80	9.5	9.2
	5.5	261.56	922	2.37	44500	PL0330280 - M --- .55 A	80	9.5	9.1
	4.5	316.41	1116	1.99	44500	PL0330315 - M --- .55 A	80	9.4	9.0
	3.8	376.44	1327	1.26	44500	PL0330360 - M --- .55 A	80	9.3	9.0
	3.5	413.19	1442	2.65	44500	PL0340400 - M --- .55 A	80	7.3	7.0
	2.9	500.89	1748	2.21	44500	PL0340500 - M --- .55 A	80	7.3	7.0
	2.6	544.57	1900	2.04	44500	PL0340560 - M --- .55 A	80	7.2	7.0
	2.4	607.20	2119	1.84	44500	PL0340630 - M --- .55 A	80	7.2	7.0
	2.2	658.75	2299	1.71	44500	PL0340710 - M --- .55 A	80	7.2	6.9
	1.8	796.88	2781	1.43	44500	PL0340800 - M --- .55 A	80	7.2	6.9
	1.6	868.19	3029	1.32	44500	PL0340900 - M --- .55 A	80	7.2	6.9
	1.5	966.01	3371	1.19	44500	PL034010C - M --- .55 A	80	7.1	6.9
	1.4	1050.24	3665	1.10	44500	PL034011C - M --- .55 A	80	7.1	6.9
	1.1	1270.45	4433	0.92	44500	PL034012C - M --- .55 A	80	7.1	6.8
	4.5	316.41	1116	3.05	44500	PL0530315 - M --- .55 A	80	9.9	9.5
	3.8	376.44	1327	1.93	44500	PL0530360 - M --- .55 A	80	9.8	9.4
	3.5	413.19	1442	4.07	44500	PL0540400 - M --- .55 A	80	7.6	7.4
	2.9	500.89	1748	3.40	44500	PL0540500 - M --- .55 A	80	7.6	7.3
	2.6	544.57	1900	3.14	44500	PL0540560 - M --- .55 A	80	7.6	7.3
	2.4	607.20	2119	2.84	44500	PL0540630 - M --- .55 A	80	7.6	7.3
	2.2	658.75	2299	2.63	44500	PL0540710 - M --- .55 A	80	7.5	7.3
	1.8	796.88	2781	2.20	44500	PL0540800 - M --- .55 A	80	7.5	7.2
	1.6	868.19	3029	2.03	44500	PL0540900 - M --- .55 A	80	7.5	7.2
1.5	966.01	3371	1.84	44500	PL054010C - M --- .55 A	80	7.5	7.2	
1.4	1050.24	3665	1.70	44500	PL054011C - M --- .55 A	80	7.4	7.2	
1.1	1270.45	4433	1.42	44500	PL054012C - M --- .55 A	80	7.4	7.2	
0.93	1536.83	5363	1.19	44500	PL054014C - M --- .55 A	80	7.4	7.1	
1.9	746.46	2605	4.07	52000	PL0840710 - M --- .55 A	80	10.6	10.0	
1.8	787.68	2749	3.87	52000	PL0840800 - M --- .55 A	80	10.6	10.0	
1.6	894.16	3120	3.44	52000	PL0840900 - M --- .55 A	80	10.6	10.0	
1.5	952.83	3325	3.24	52000	PL084010C - M --- .55 A	80	10.6	9.9	
1.2	1152.62	4022	2.71	52000	PL084011C - M --- .55 A	80	10.5	9.9	
1.0	1371.33	4785	2.30	52000	PL084012C - M --- .55 A	80	10.5	9.8	
0.97	1471.29	5134	1.28	52000	PL084014C - M --- .55 A	80	10.5	9.8	
0.87	1642.66	5732	1.67	52000	PL084016C - M --- .55 A	80	10.4	9.8	
0.80	1779.79	6210	1.07	52000	PL084018C - M --- .55 A	80	10.4	9.8	
0.68	2117.49	7389	0.91	52000	PL084020C - M --- .55 A	80	10.4	9.7	

SERIES P

PL MOTORISED RATINGS

	N2	Ratio <i>i</i>	M2 (NM)	fm	FR2 (N)	Unit Designation	Motor Frame	PT(kW) Type B	PT (kW) Type F	
0.55 kW 4 - Pole	1.5	952.83	3325	4.01	52000	PL124010C - M --- .55 A	80	11.2	10.5	
	1.2	1152.62	4022	3.36	52000	PL124011C - M --- .55 A	80	11.1	10.5	
	1.0	1371.33	4785	2.85	52000	PL124012C - M --- .55 A	80	11.1	10.4	
	0.97	1471.29	5134	1.70	52000	PL124014C - M --- .55 A	80	11.1	10.4	
	0.87	1642.66	5732	2.13	52000	PL124016C - M --- .55 A	80	11.0	10.4	
	0.80	1779.79	6210	1.43	52000	PL124018C - M --- .55 A	80	11.0	10.4	
	0.68	2117.49	7389	1.21	52000	PL124020C - M --- .55 A	80	10.9	10.3	
	0.57	2519.27	8791	0.87	52000	PL124025C - M --- .55 A	80	10.9	10.3	
	1.17	1226.07	4278	4.64	54000	PL164012C - M --- .55 A	80	18.9	13.1	
	0.98	1458.71	5090	3.95	54000	PL164014C - M --- .55 A	80	18.8	13.1	
	0.95	1504.10	5248	2.99	54000	PL164016C - M --- .55 A	80	18.7	13.1	
	0.79	1819.47	6349	2.50	54000	PL164018C - M --- .55 A	80	18.7	13.0	
	0.68	2100.55	7330	1.36	54000	PL164020C - M --- .55 A	80	18.6	13.0	
	0.56	2540.99	8867	1.13	54000	PL164025C - M --- .55 A	80	18.5	12.9	
	0.82	1746.69	6095	3.56	80000	PL254018C - M --- .55 A	80	-	13.6	
	0.68	2099.39	7326	2.26	80000	PL254020C - M --- .55 A	80	-	13.5	
	0.75 kW 4 - Pole	20.3	71.30	338	3.29	15000	PL013071. - M --- .75 A	80	6.9	6.3
		16.8	86.43	410	2.75	15000	PL013080. - M --- .75 A	80	6.8	6.2
		15.5	93.77	445	2.55	15000	PL013090. - M --- .75 A	80	6.8	6.2
13.8		104.77	497	1.86	15000	PL0130100 - M --- .75 A	80	6.7	6.2	
12.8		113.43	538	2.13	15000	PL0130112 - M --- .75 A	80	6.7	6.2	
10.5		137.50	652	1.78	15000	PL0130125 - M --- .75 A	80	6.7	6.1	
9.7		149.49	709	1.65	15000	PL0130140 - M --- .75 A	80	6.6	6.1	
8.7		166.68	790	1.21	15000	PL0130160 - M --- .75 A	80	6.6	6.0	
8.0		180.83	858	1.38	15000	PL0130180 - M --- .75 A	80	6.6	6.0	
6.6		218.75	1037	1.15	15000	PL0130225 - M --- .75 A	80	6.5	6.0	
5.5		265.18	1257	0.78	15000	PL0130250 - M --- .75 A	80	6.5	5.9	
5.0		288.30	1367	0.50	15000	PL0130280 - M --- .75 A	80	6.4	5.9	
4.2		348.75	1654	0.42	15000	PL0130360 - M --- .75 A	80	6.4	5.8	
3.4		421.88	2001	0.26	15000	PL0130400 - M --- .75 A	80	6.3	5.8	
5.2		277.26	1315	0.92	15000	PL0140280 - M --- .75 A	80	5.6	5.2	
4.3		336.11	1594	0.77	15000	PL0140315 - M --- .75 A	80	5.5	5.1	
13.8		104.77	497	3.44	15000	PL0230100 - M --- .75 A	80	6.9	6.4	
12.8		113.43	538	3.94	15000	PL0230112 - M --- .75 A	80	6.9	6.3	
10.5		137.50	652	3.29	15000	PL0230125 - M --- .75 A	80	6.8	6.3	
9.7		149.49	709	3.04	15000	PL0230140 - M --- .75 A	80	6.8	6.3	
8.7		166.68	790	2.22	15000	PL0230160 - M --- .75 A	80	6.8	6.2	
8.0		180.83	858	2.54	15000	PL0230180 - M --- .75 A	80	6.8	6.2	
6.6		218.75	1037	2.13	15000	PL0230225 - M --- .75 A	80	6.7	6.1	
5.5		265.18	1257	1.44	15000	PL0230250 - M --- .75 A	80	6.6	6.1	
5.0		288.30	1367	0.93	15000	PL0230280 - M --- .75 A	80	6.6	6.1	
4.2		348.75	1654	0.78	15000	PL0230360 - M --- .75 A	80	6.6	6.0	
5.2		277.26	1315	1.70	15000	PL0240280 - M --- .75 A	80	5.7	5.3	
4.3		336.11	1594	1.42	15000	PL0240315 - M --- .75 A	80	5.7	5.2	
4.0		364.64	1729	1.32	15000	PL0240360 - M --- .75 A	80	5.4	5.0	
3.3		441.10	2092	1.10	15000	PL0240450 - M --- .75 A	80	5.2	4.8	
2.7		534.72	2536	0.92	15000	PL0240500 - M --- .75 A	80	4.8	4.4	
2.5		581.35	2757	0.85	15000	PL0240560 - M --- .75 A	80	4.8	4.4	
7.0		204.91	985	3.70	44500	PL0330200 - M --- .75 A	80	9.6	9.2	
5.8		245.45	1180	2.66	44500	PL0330250 - M --- .75 A	80	9.5	9.2	
5.5		261.56	1258	1.74	44500	PL0330280 - M --- .75 A	80	9.5	9.1	
4.5		316.41	1521	1.46	44500	PL0330315 - M --- .75 A	80	9.4	9.0	
3.8		376.44	1810	0.92	44500	PL0330360 - M --- .75 A	80	9.3	9.0	
5.5		259.72	1236	3.00	44500	PL0340250 - M --- .75 A	80	8.0	7.7	
4.5		314.85	1498	2.50	44500	PL0340315 - M --- .75 A	80	7.9	7.6	
4.2		341.57	1625	2.32	44500	PL0340360 - M --- .75 A	80	7.5	7.2	
2.9		500.89	2383	1.62	44500	PL0340500 - M --- .75 A	80	7.3	7.0	
2.6		544.57	2591	1.50	44500	PL0340560 - M --- .75 A	80	7.2	7.0	
2.4		607.20	2889	1.35	44500	PL0340630 - M --- .75 A	80	7.2	7.0	
2.2		658.75	3135	1.25	44500	PL0340710 - M --- .75 A	80	7.2	6.9	
1.8		796.88	3792	1.05	44500	PL0340800 - M --- .75 A	80	7.2	6.9	
1.6		868.19	4131	0.97	44500	PL0340900 - M --- .75 A	80	7.2	6.9	
1.5		966.01	4597	0.88	44500	PL034010C - M --- .75 A	80	7.1	6.9	
5.8		245.45	1180	4.09	44500	PL0530250 - M --- .75 A	80	10.0	9.6	
5.5		261.56	1258	2.68	44500	PL0530280 - M --- .75 A	80	10.0	9.6	
4.5		316.41	1521	2.24	44500	PL0530315 - M --- .75 A	80	9.9	9.5	
3.8		376.44	1810	1.42	44500	PL0530360 - M --- .75 A	80	9.8	9.4	
4.5		314.85	1498	3.85	44500	PL0540315 - M --- .75 A	80	8.2	7.9	
4.2		341.57	1625	3.57	44500	PL0540360 - M --- .75 A	80	7.8	7.6	
3.5		413.19	1966	2.98	44500	PL0540400 - M --- .75 A	80	7.6	7.4	
2.9		500.89	2383	2.49	44500	PL0540500 - M --- .75 A	80	7.6	7.3	
2.6		544.57	2591	2.30	44500	PL0540560 - M --- .75 A	80	7.6	7.3	
2.4		607.20	2889	2.08	44500	PL0540630 - M --- .75 A	80	7.6	7.3	
2.2	658.75	3135	1.93	44500	PL0540710 - M --- .75 A	80	7.5	7.3		
1.8	796.88	3792	1.61	44500	PL0540800 - M --- .75 A	80	7.5	7.2		
1.6	868.19	4131	1.49	44500	PL0540900 - M --- .75 A	80	7.5	7.2		

SERIES P

PL MOTORISED RATINGS

	N2	Ratio <i>i</i>	M2 (NM)	fm	FR2 (N)	Unit Designation	Motor Frame	PT(kW) Type B	PT (kW) Type F	
0.75 kW 4 - Pole	1.5	966.01	4597	1.35	44500	PL054010C - M --- .75 A	80	7.5	7.2	
	1.4	1050.24	4997	1.25	44500	PL054011C - M --- .75 A	80	7.4	7.2	
	1.1	1270.45	6045	1.04	44500	PL054012C - M --- .75 A	80	7.4	7.2	
	0.9	1536.83	7313	0.87	44500	PL054014C - M --- .75 A	80	7.4	7.1	
	5.1	282.33	1358	4.35	52000	PL0830280 - M --- .75 A	80	14.7	13.8	
	4.3	335.90	1615	3.13	52000	PL0830360 - M --- .75 A	80	14.6	13.7	
	4.5	319.96	1522	6.61	52000	PL0840360 - M --- .75 A	80	11.1	10.4	
	3.7	387.05	1842	5.53	52000	PL0840400 - M --- .75 A	80	10.8	10.2	
	3.0	469.20	2233	4.62	52000	PL0840450 - M --- .75 A	80	10.8	10.1	
	2.8	510.11	2427	4.27	52000	PL0840500 - M --- .75 A	80	10.8	10.1	
	2.5	562.04	2674	3.90	52000	PL0840560 - M --- .75 A	80	10.7	10.1	
	2.3	617.07	2936	3.57	52000	PL0840630 - M --- .75 A	80	10.7	10.1	
	1.9	746.46	3552	2.99	52000	PL0840710 - M --- .75 A	80	10.6	10.0	
	1.8	787.68	3748	2.84	52000	PL0840800 - M --- .75 A	80	10.6	10.0	
	1.6	894.16	4255	2.52	52000	PL0840900 - M --- .75 A	80	10.6	10.0	
	1.5	952.83	4534	2.38	52000	PL084010C - M --- .75 A	80	10.6	9.9	
	1.2	1152.62	5485	1.99	52000	PL084011C - M --- .75 A	80	10.5	9.9	
	1.0	1371.33	6525	1.69	52000	PL084012C - M --- .75 A	80	10.5	9.8	
	0.97	1471.29	7001	0.94	52000	PL084014C - M --- .75 A	80	10.5	9.8	
	0.87	1642.66	7816	1.23	52000	PL084016C - M --- .75 A	80	10.4	9.8	
	1.9	746.46	3552	3.70	52000	PL1240710 - M --- .75 A	80	11.3	10.6	
	1.8	787.68	3748	3.52	52000	PL1240800 - M --- .75 A	80	11.2	10.6	
	1.6	894.16	4255	3.12	52000	PL1240900 - M --- .75 A	80	11.2	10.6	
	1.5	952.83	4534	2.94	52000	PL124010C - M --- .75 A	80	11.2	10.5	
	1.2	1152.62	5485	2.46	52000	PL124011C - M --- .75 A	80	11.1	10.5	
	1.0	1371.33	6525	2.09	52000	PL124012C - M --- .75 A	80	11.1	10.4	
	0.97	1471.29	7001	1.25	52000	PL124014C - M --- .75 A	80	11.1	10.4	
	0.87	1642.66	7816	1.57	52000	PL124016C - M --- .75 A	80	11.0	10.4	
	0.80	1779.79	8469	1.05	52000	PL124018C - M --- .75 A	80	11.0	10.4	
	0.68	2117.49	10076	0.89	52000	PL124020C - M --- .75 A	80	10.9	10.3	
	1.41	1013.55	4823	4.07	54000	PL164010C - M --- .75 A	80	18.9	13.2	
	1.17	1226.07	5834	3.41	54000	PL164012C - M --- .75 A	80	18.9	13.1	
	0.98	1458.71	6941	2.89	54000	PL164014C - M --- .75 A	80	18.8	13.1	
	0.95	1504.10	7157	2.20	54000	PL164016C - M --- .75 A	80	18.7	13.1	
	0.79	1819.47	8658	1.84	54000	PL164018C - M --- .75 A	80	18.7	13.0	
	0.68	2100.55	9995	0.99	54000	PL164020C - M --- .75 A	80	18.6	13.0	
	0.56	2540.99	12091	0.83	54000	PL164025C - M --- .75 A	80	18.5	12.9	
	0.97	1468.13	6986	3.07	80000	PL254014C - M --- .75 A	80	-	13.7	
	0.82	1746.69	8311	2.61	80000	PL254018C - M --- .75 A	80	-	13.6	
	0.68	2099.39	9990	1.66	80000	PL254020C - M --- .75 A	80	-	13.5	
	0.81	1793.64	8683	4.04	110000	PL404018C - M --- .75 A	80	-	17.5	
	0.69	2105.39	10192	2.92	110000	PL404020C - M --- .75 A	80	-	17.5	
	1.1 kW 4 - Pole	37.7	38.44	270	2.25	15000	PL012040. - M --- 1.1 A	90	8.5	7.7
		31.2	46.50	327	1.88	15000	PL012045. - M --- 1.1 A	90	8.4	7.5
		25.8	56.25	395	1.16	15000	PL012056. - M --- 1.1 A	90	8.2	7.4
		24.7	58.81	409	2.69	15000	PL013063. - M --- 1.1 A	90	6.9	6.4
		20.3	71.30	496	2.25	15000	PL013071. - M --- 1.1 A	90	6.9	6.3
		16.8	86.43	601	1.88	15000	PL013080. - M --- 1.1 A	90	6.8	6.2
		15.5	93.77	652	1.74	15000	PL013090. - M --- 1.1 A	90	6.8	6.2
		13.8	104.77	729	1.27	15000	PL0130100 - M --- 1.1 A	90	6.7	6.2
12.8		113.43	789	1.45	15000	PL0130112 - M --- 1.1 A	90	6.7	6.2	
10.5		137.50	956	1.21	15000	PL0130125 - M --- 1.1 A	90	6.7	6.1	
9.7		149.49	1040	1.12	15000	PL0130140 - M --- 1.1 A	90	6.6	6.1	
8.7		166.68	1159	0.82	15000	PL0130160 - M --- 1.1 A	90	6.6	6.0	
8.0		180.83	1258	0.94	15000	PL0130180 - M --- 1.1 A	90	6.6	6.0	
6.6		218.75	1521	0.79	15000	PL0130225 - M --- 1.1 A	90	6.5	6.0	
31.2		46.50	327	3.47	15000	PL022045. - M --- 1.1 A	90	9.1	8.2	
25.8		56.25	395	2.14	15000	PL022056. - M --- 1.1 A	90	8.9	8.0	
20.3		71.30	496	4.15	15000	PL023071. - M --- 1.1 A	90	7.1	6.5	
16.8		86.43	601	3.46	15000	PL023080. - M --- 1.1 A	90	7.0	6.4	
15.5		93.77	652	3.21	15000	PL023090. - M --- 1.1 A	90	7.0	6.4	
13.8		104.77	729	2.34	15000	PL0230100 - M --- 1.1 A	90	6.9	6.4	
12.8		113.43	789	2.68	15000	PL0230112 - M --- 1.1 A	90	6.9	6.3	
10.5		137.50	956	2.24	15000	PL0230125 - M --- 1.1 A	90	6.8	6.3	
9.7		149.49	1040	2.07	15000	PL0230140 - M --- 1.1 A	90	6.8	6.3	
8.7		166.68	1159	1.52	15000	PL0230160 - M --- 1.1 A	90	6.8	6.2	
8.0		180.83	1258	1.73	15000	PL0230180 - M --- 1.1 A	90	6.8	6.2	
6.6		218.75	1521	1.45	15000	PL0230225 - M --- 1.1 A	90	6.7	6.1	
5.5		265.18	1844	0.98	15000	PL0230250 - M --- 1.1 A	90	6.6	6.1	
5.2		277.26	1928	1.16	15000	PL0240280 - M --- 1.1 A	90	5.7	5.3	
4.3		336.11	2338	0.97	15000	PL0240315 - M --- 1.1 A	90	5.7	5.2	
4.0		364.64	2536	0.90	15000	PL0240360 - M --- 1.1 A	90	5.4	5.0	
11.1		128.80	908	3.90	44500	PL0330125 - M --- 1.1 A	90	9.8	9.4	
10.2		140.03	988	3.61	44500	PL0330140 - M --- 1.1 A	90	9.8	9.4	

SERIES P

PL MOTORISED RATINGS

	N2	Ratio <i>i</i>	M2 (NM)	fm	FR2 (N)	Unit Designation	Motor Frame	PT(kW) Type B	PT (kW) Type F
1.1 kW 4 - Pole	9.3	154.29	1088	2.80	44500	PL0330160 - M --- 1.1 A	90	9.7	9.4
	8.4	169.39	1195	3.02	44500	PL0330180 - M --- 1.1 A	90	9.7	9.3
	7.0	204.91	1445	2.53	44500	PL0330200 - M --- 1.1 A	90	9.6	9.2
	5.8	245.45	1731	1.81	44500	PL0330250 - M --- 1.1 A	90	9.5	9.2
	5.5	261.56	1845	1.19	44500	PL0330280 - M --- 1.1 A	90	9.5	9.1
	4.5	316.41	2231	0.99	44500	PL0330315 - M --- 1.1 A	90	9.4	9.0
	5.5	259.72	1832	2.02	44500	PL0340250 - M --- 1.1 A	90	8.0	7.7
	4.5	314.85	2220	1.69	44500	PL0340315 - M --- 1.1 A	90	7.9	7.6
	4.2	341.57	2409	1.56	44500	PL0340360 - M --- 1.1 A	90	7.5	7.2
	3.5	413.19	2914	1.31	44500	PL0340400 - M --- 1.1 A	90	7.3	7.0
2.9	500.89	3532	1.09	44500	PL0340500 - M --- 1.1 A	90	7.3	7.0	
2.6	544.57	3840	1.01	44500	PL0340560 - M --- 1.1 A	90	7.2	7.0	
2.4	607.20	4282	0.91	44500	PL0340630 - M --- 1.1 A	90	7.2	7.0	
7.0	204.91	1445	3.89	44500	PL0530200 - M --- 1.1 A	90	10.1	9.7	
5.8	245.45	1731	2.79	44500	PL0530250 - M --- 1.1 A	90	10.0	9.6	
5.5	261.56	1845	1.83	44500	PL0530280 - M --- 1.1 A	90	10.0	9.6	
4.5	316.41	2231	1.53	44500	PL0530315 - M --- 1.1 A	90	9.9	9.5	
3.8	376.44	2655	0.97	44500	PL0530360 - M --- 1.1 A	90	9.8	9.4	
5.5	259.72	1813	3.14	44500	PL0540250 - M --- 1.1 A	90	8.4	8.1	
4.5	314.85	2197	2.63	44500	PL0540315 - M --- 1.1 A	90	8.2	7.9	
4.2	341.57	2384	2.43	44500	PL0540360 - M --- 1.1 A	90	7.8	7.6	
3.5	413.19	2884	2.04	44500	PL0540400 - M --- 1.1 A	90	7.6	7.4	
2.9	500.89	3496	1.70	44500	PL0540500 - M --- 1.1 A	90	7.6	7.3	
2.6	544.57	3800	1.57	44500	PL0540560 - M --- 1.1 A	90	7.6	7.3	
2.4	607.20	4238	1.42	44500	PL0540630 - M --- 1.1 A	90	7.6	7.3	
2.2	658.75	4597	1.31	44500	PL0540710 - M --- 1.1 A	90	7.5	7.3	
1.8	796.88	5561	1.10	44500	PL0540800 - M --- 1.1 A	90	7.5	7.2	
1.6	868.19	6059	1.01	44500	PL0540900 - M --- 1.1 A	90	7.5	7.2	
1.5	966.01	6742	0.92	44500	PL054010C - M --- 1.1 A	90	7.5	7.2	
6.0	237.30	1674	3.49	52000	PL0830250 - M --- 1.1 A	90	14.9	13.9	
5.1	282.33	1991	2.97	52000	PL0830280 - M --- 1.1 A	90	14.7	13.8	
4.3	335.90	2369	2.13	52000	PL0830360 - M --- 1.1 A	90	14.6	13.7	
4.8	294.93	2058	4.86	52000	PL0840315 - M --- 1.1 A	90	11.5	10.8	
4.5	319.96	2233	4.50	52000	PL0840360 - M --- 1.1 A	90	11.1	10.4	
3.7	387.05	2701	3.77	52000	PL0840400 - M --- 1.1 A	90	10.8	10.2	
3.0	469.20	3275	3.15	52000	PL0840450 - M --- 1.1 A	90	10.8	10.1	
2.8	510.11	3560	2.91	52000	PL0840500 - M --- 1.1 A	90	10.8	10.1	
2.5	562.04	3922	2.66	52000	PL0840560 - M --- 1.1 A	90	10.7	10.1	
2.3	617.07	4306	2.43	52000	PL0840630 - M --- 1.1 A	90	10.7	10.1	
1.9	746.46	5209	2.04	52000	PL0840710 - M --- 1.1 A	90	10.6	10.0	
1.8	787.68	5497	1.94	52000	PL0840800 - M --- 1.1 A	90	10.6	10.0	
1.6	894.16	6240	1.72	52000	PL0840900 - M --- 1.1 A	90	10.6	10.0	
1.5	952.83	6650	1.62	52000	PL084010C - M --- 1.1 A	90	10.6	9.9	
1.2	1152.62	8044	1.36	52000	PL084011C - M --- 1.1 A	90	10.5	9.9	
1.0	1371.33	9570	1.15	52000	PL084012C - M --- 1.1 A	90	10.5	9.8	
1.0	1471.29	10268	0.64	52000	PL084014C - M --- 1.1 A	90	10.5	9.8	
0.9	1642.66	11464	0.84	52000	PL084016C - M --- 1.1 A	90	10.4	9.8	
4.3	335.90	2369	2.84	52000	PL1230360 - M --- 1.1 A	90	15.5	14.6	
4.5	319.96	2233	5.58	52000	PL1240360 - M --- 1.1 A	90	11.8	11.1	
3.7	387.05	2701	4.66	52000	PL1240400 - M --- 1.1 A	90	11.5	10.8	
3.0	469.20	3275	3.89	52000	PL1240450 - M --- 1.1 A	90	11.4	10.7	
2.8	510.11	3560	3.60	52000	PL1240500 - M --- 1.1 A	90	11.4	10.7	
2.5	562.04	3922	3.29	52000	PL1240560 - M --- 1.1 A	90	11.3	10.7	
2.3	617.07	4306	3.01	52000	PL1240630 - M --- 1.1 A	90	11.3	10.7	
1.9	746.46	5209	2.52	52000	PL1240710 - M --- 1.1 A	90	11.3	10.6	
1.8	787.68	5497	2.40	52000	PL1240800 - M --- 1.1 A	90	11.2	10.6	
1.6	894.16	6240	2.13	52000	PL1240900 - M --- 1.1 A	90	11.2	10.6	
1.5	952.83	6650	2.01	52000	PL124010C - M --- 1.1 A	90	11.2	10.5	
1.2	1152.62	8044	1.68	52000	PL124011C - M --- 1.1 A	90	11.1	10.5	
1.0	1371.33	9570	1.43	52000	PL124012C - M --- 1.1 A	90	11.1	10.4	
0.97	1471.29	10268	0.85	52000	PL124014C - M --- 1.1 A	90	11.1	10.4	
4.22	338.80	2389	3.71	54000	PL1630280 - M --- 1.1 A	90	27.1	18.7	
4.20	340.35	2400	3.69	54000	PL1630315 - M --- 1.1 A	90	26.9	18.6	
4.20	340.35	2375	7.72	54000	PL1640360 - M --- 1.1 A	90	19.4	13.5	
3.47	411.72	2873	6.46	54000	PL1640400 - M --- 1.1 A	90	19.4	13.5	
2.87	499.10	3483	5.39	54000	PL1640500 - M --- 1.1 A	90	19.3	13.5	
2.64	542.62	3787	4.98	54000	PL1640560 - M --- 1.1 A	90	19.3	13.4	
2.39	597.86	4172	4.55	54000	PL1640630 - M --- 1.1 A	90	19.2	13.4	
2.18	656.40	4581	4.17	54000	PL1640710 - M --- 1.1 A	90	19.2	13.4	
1.80	794.03	5541	3.49	54000	PL1640800 - M --- 1.1 A	90	19.1	13.3	
1.50	951.14	6638	2.95	54000	PL1640900 - M --- 1.1 A	90	19.0	13.2	
1.41	1013.55	7073	2.78	54000	PL164010C - M --- 1.1 A	90	18.9	13.2	
1.17	1226.07	8557	2.32	54000	PL164012C - M --- 1.1 A	90	18.9	13.1	
0.98	1458.71	10180	1.97	54000	PL164014C - M --- 1.1 A	90	18.8	13.1	
0.95	1504.10	10497	1.50	54000	PL164016C - M --- 1.1 A	90	18.7	13.1	
0.79	1819.47	12698	1.25	54000	PL164018C - M --- 1.1 A	90	18.7	13.0	

SERIES P

PL MOTORISED RATINGS

	N2	Ratio <i>i</i>	M2 (NM)	fm	FR2 (N)	Unit Designation	Motor Frame	PT(kW) Type B	PT (kW) Type F
1.1 kW 4 - Pole	1.51	949.22	6624	4.17	80000	PL254010C - M --- 1.1 A	90	-	13.8
	1.27	1129.33	7881	3.54	80000	PL254011C - M --- 1.1 A	90	-	13.7
	1.06	1343.61	9377	3.01	80000	PL254012C - M --- 1.1 A	90	-	13.7
	0.97	1468.13	10246	2.09	80000	PL254014C - M --- 1.1 A	90	-	13.7
	0.82	1746.69	12190	1.78	80000	PL254018C - M --- 1.1 A	90	-	13.6
	0.68	2099.39	14651	1.13	80000	PL254020C - M --- 1.1 A	90	-	13.5
	0.81	1793.64	12735	2.76	110000	PL404018C - M --- 1.1 A	90	-	17.5
	0.69	2105.39	14948	1.99	110000	PL404020C - M --- 1.1 A	90	-	17.5
1.5 kW 4 - Pole	41.0	35.36	339	2.55	15000	PL012036. - M --- 1.5 A	90	8.6	7.8
	37.7	38.44	368	1.65	15000	PL012040. - M --- 1.5 A	90	8.5	7.7
	31.2	46.50	446	1.38	15000	PL012045. - M --- 1.5 A	90	8.4	7.5
	25.8	56.25	539	0.85	15000	PL012056. - M --- 1.5 A	90	8.2	7.4
	24.7	58.81	558	1.97	15000	PL013063. - M --- 1.5 A	90	6.9	6.4
	20.3	71.30	676	1.65	15000	PL013071. - M --- 1.5 A	90	6.9	6.3
	16.8	86.43	820	1.38	15000	PL013080. - M --- 1.5 A	90	6.8	6.2
	15.5	93.77	889	1.27	15000	PL013090. - M --- 1.5 A	90	6.8	6.2
	13.8	104.77	994	0.93	15000	PL0130100 - M --- 1.5 A	90	6.7	6.2
	12.8	113.43	1076	1.07	15000	PL0130112 - M --- 1.5 A	90	6.7	6.2
	10.5	137.50	1304	0.89	15000	PL0130125 - M --- 1.5 A	90	6.7	6.1
	37.7	38.44	368	3.04	15000	PL022040. - M --- 1.5 A	90	9.3	8.4
	31.2	46.50	446	2.55	15000	PL022045. - M --- 1.5 A	90	9.1	8.2
	25.8	56.25	539	1.57	15000	PL022056. - M --- 1.5 A	90	8.9	8.0
	24.7	58.81	558	3.64	15000	PL023063. - M --- 1.5 A	90	7.1	6.5
	20.3	71.30	676	3.04	15000	PL023071. - M --- 1.5 A	90	7.1	6.5
	16.8	86.43	820	2.54	15000	PL023080. - M --- 1.5 A	90	7.0	6.4
	15.5	93.77	889	2.35	15000	PL023090. - M --- 1.5 A	90	7.0	6.4
	13.8	104.77	994	1.72	15000	PL0230100 - M --- 1.5 A	90	6.9	6.4
	12.8	113.43	1076	1.97	15000	PL0230112 - M --- 1.5 A	90	6.9	6.3
	10.5	137.50	1304	1.64	15000	PL0230125 - M --- 1.5 A	90	6.8	6.3
	9.7	149.49	1418	1.52	15000	PL0230140 - M --- 1.5 A	90	6.8	6.3
	8.7	166.68	1581	1.11	15000	PL0230160 - M --- 1.5 A	90	6.8	6.2
	8.0	180.83	1715	1.27	15000	PL0230180 - M --- 1.5 A	90	6.8	6.2
	6.6	218.75	2075	1.06	15000	PL0230225 - M --- 1.5 A	90	6.7	6.1
	14.7	96.98	933	3.17	44500	PL0330100 - M --- 1.5 A	90	10.0	9.6
	13.4	106.48	1024	3.42	44500	PL0330112 - M --- 1.5 A	90	9.9	9.5
	11.1	128.80	1239	2.86	44500	PL0330125 - M --- 1.5 A	90	9.8	9.4
	10.2	140.03	1347	2.65	44500	PL0330140 - M --- 1.5 A	90	9.8	9.4
	9.3	154.29	1484	2.05	44500	PL0330160 - M --- 1.5 A	90	9.7	9.4
	8.4	169.39	1629	2.21	44500	PL0330180 - M --- 1.5 A	90	9.7	9.3
	7.0	204.91	1971	1.85	44500	PL0330200 - M --- 1.5 A	90	9.6	9.2
	5.8	245.45	2360	1.33	44500	PL0330250 - M --- 1.5 A	90	9.5	9.2
	5.5	261.56	2515	0.87	44500	PL0330280 - M --- 1.5 A	90	9.5	9.1
	5.5	259.72	2498	1.48	44500	PL0340250 - M --- 1.5 A	90	8.0	7.7
	4.5	314.85	3028	1.24	44500	PL0340315 - M --- 1.5 A	90	7.9	7.6
	4.2	341.57	3285	1.15	44500	PL0340360 - M --- 1.5 A	90	7.5	7.2
	3.5	413.19	3974	0.96	44500	PL0340400 - M --- 1.5 A	90	7.3	7.0
	2.9	500.89	4817	0.80	44500	PL0340500 - M --- 1.5 A	90	7.3	7.0
	9.3	154.29	1484	3.16	44500	PL0530160 - M --- 1.5 A	90	10.2	9.8
	8.4	169.39	1629	3.41	44500	PL0530180 - M --- 1.5 A	90	10.2	9.8
	7.0	204.91	1971	2.85	44500	PL0530200 - M --- 1.5 A	90	10.1	9.7
	5.8	245.45	2360	2.04	44500	PL0530250 - M --- 1.5 A	90	10.0	9.6
	5.5	261.56	2515	1.34	44500	PL0530280 - M --- 1.5 A	90	10.0	9.6
	4.5	316.41	3043	1.12	44500	PL0530315 - M --- 1.5 A	90	9.9	9.5
	5.5	259.72	2472	2.31	44500	PL0540250 - M --- 1.5 A	90	8.4	8.1
	4.5	314.85	2996	1.93	44500	PL0540315 - M --- 1.5 A	90	8.2	7.9
	4.2	341.57	3251	1.78	44500	PL0540360 - M --- 1.5 A	90	7.8	7.6
3.5	413.19	3932	1.49	44500	PL0540400 - M --- 1.5 A	90	7.6	7.4	
2.9	500.89	4767	1.25	44500	PL0540500 - M --- 1.5 A	90	7.6	7.3	
2.6	544.57	5182	1.15	44500	PL0540560 - M --- 1.5 A	90	7.6	7.3	
2.4	607.20	5779	1.04	44500	PL0540630 - M --- 1.5 A	90	7.6	7.3	
2.2	658.75	6269	0.96	44500	PL0540710 - M --- 1.5 A	90	7.5	7.3	
6.53	219.02	2106	4.01	52000	PL0830225 - M --- 1.5 A	90	14.9	14.0	
6.03	237.30	2282	2.56	52000	PL0830250 - M --- 1.5 A	90	14.9	13.9	
5.06	282.33	2715	2.18	52000	PL0830280 - M --- 1.5 A	90	14.7	13.8	
4.26	335.90	3230	1.56	52000	PL0830360 - M --- 1.5 A	90	14.6	13.7	
3.69	387.05	3683	2.76	52000	PL0840400 - M --- 1.5 A	90	10.8	10.2	
3.05	469.20	4465	2.31	52000	PL0840450 - M --- 1.5 A	90	10.8	10.1	
2.80	510.11	4855	2.13	52000	PL0840500 - M --- 1.5 A	90	10.8	10.1	
2.54	562.04	5349	1.95	52000	PL0840560 - M --- 1.5 A	90	10.7	10.1	
2.32	617.07	5872	1.79	52000	PL0840630 - M --- 1.5 A	90	10.7	10.1	
1.92	746.46	7104	1.49	52000	PL0840710 - M --- 1.5 A	90	10.6	10.0	
1.82	787.68	7496	1.42	52000	PL0840800 - M --- 1.5 A	90	10.6	10.0	
1.60	894.16	8509	1.26	52000	PL0840900 - M --- 1.5 A	90	10.6	10.0	
1.50	952.83	9068	1.19	52000	PL084010C - M --- 1.5 A	90	10.6	9.9	
1.24	1152.62	10969	0.99	52000	PL084011C - M --- 1.5 A	90	10.5	9.9	
1.04	1371.33	13050	0.84	52000	PL084012C - M --- 1.5 A	90	10.5	9.8	

SERIES P

PL MOTORISED RATINGS

	N2	Ratio <i>i</i>	M2 (NM)	fm	FR2 (N)	Unit Designation	Motor Frame	PT(kW) Type B	PT (kW) Type F	
1.5 kW	5.06	282.33	2715	2.90	52000	PL1230280 - M --- 1.5 A	90	15.6	14.7	
	4.26	335.90	3230	2.09	52000	PL1230360 - M --- 1.5 A	90	15.5	14.6	
4 - Pole	4.85	294.93	2807	4.41	52000	PL1240315 - M --- 1.5 A	90	12.1	11.4	
	4.47	319.96	3045	4.09	52000	PL1240360 - M --- 1.5 A	90	11.8	11.1	
	3.69	387.05	3683	3.42	52000	PL1240400 - M --- 1.5 A	90	11.5	10.8	
	3.05	469.20	4465	2.86	52000	PL1240450 - M --- 1.5 A	90	11.4	10.7	
	2.80	510.11	4855	2.64	52000	PL1240500 - M --- 1.5 A	90	11.4	10.7	
	2.54	562.04	5349	2.41	52000	PL1240560 - M --- 1.5 A	90	11.3	10.7	
	2.32	617.07	5872	2.21	52000	PL1240630 - M --- 1.5 A	90	11.3	10.7	
	1.92	746.46	7104	1.85	52000	PL1240710 - M --- 1.5 A	90	11.3	10.6	
	1.82	787.68	7496	1.76	52000	PL1240800 - M --- 1.5 A	90	11.2	10.6	
	1.60	894.16	8509	1.56	52000	PL1240900 - M --- 1.5 A	90	11.2	10.6	
	1.50	952.83	9068	1.47	52000	PL124010C - M --- 1.5 A	90	11.2	10.5	
	1.24	1152.62	10969	1.23	52000	PL124011C - M --- 1.5 A	90	11.1	10.5	
	1.04	1371.33	13050	1.05	52000	PL124012C - M --- 1.5 A	90	11.1	10.4	
	5.02	284.77	2739	3.20	54000	PL1630280 - M --- 1.5 A	90	27.1	18.7	
	4.22	338.80	3258	2.72	54000	PL1630315 - M --- 1.5 A	90	26.9	18.6	
	6.70	213.48	2032	8.76	54000	PL1640225 - M --- 1.5 A	90	12.3	11.6	
	5.53	258.79	2463	7.32	54000	PL1640280 - M --- 1.5 A	90	12.1	11.4	
	4.56	313.72	2986	6.11	54000	PL1640315 - M --- 1.5 A	90	11.8	11.1	
	4.20	340.35	3239	5.66	54000	PL1640360 - M --- 1.5 A	90	11.5	10.8	
	3.47	411.72	3918	4.73	54000	PL1640400 - M --- 1.5 A	90	11.4	10.7	
	2.87	499.10	4750	3.95	54000	PL1640500 - M --- 1.5 A	90	11.4	10.7	
	2.64	542.62	5164	3.66	54000	PL1640560 - M --- 1.5 A	90	11.3	10.7	
	2.39	597.86	5690	3.34	54000	PL1640630 - M --- 1.5 A	90	11.3	10.7	
	2.18	656.40	6247	3.06	54000	PL1640710 - M --- 1.5 A	90	11.3	10.6	
	1.80	794.03	7556	2.56	54000	PL1640800 - M --- 1.5 A	90	11.2	10.6	
	1.50	951.14	9052	2.16	54000	PL1640900 - M --- 1.5 A	90	11.2	10.6	
	1.41	1013.55	9646	2.04	54000	PL164010C - M --- 1.5 A	90	11.2	10.5	
	1.17	1226.07	11668	1.70	54000	PL164012C - M --- 1.5 A	90	11.1	10.5	
	0.98	1458.71	13882	1.45	54000	PL164014C - M --- 1.5 A	90	11.1	10.4	
	0.95	1504.10	14314	1.10	54000	PL164016C - M --- 1.5 A	90	11.1	10.4	
	0.79	1819.47	17315	0.92	54000	PL164018C - M --- 1.5 A	90	11.0	10.4	
	1.96	731.37	7033	3.86	80000	PL2540710 - M --- 1.5 A	90	-	13.9	
	1.82	784.69	7546	3.61	80000	PL2540800 - M --- 1.5 A	90	-	13.9	
	1.63	876.08	8425	3.26	80000	PL2540900 - M --- 1.5 A	90	-	13.8	
	1.51	949.22	9128	3.02	80000	PL254010C - M --- 1.5 A	90	-	13.8	
	1.27	1129.33	10860	2.57	80000	PL254011C - M --- 1.5 A	90	-	13.7	
	1.06	1343.61	12921	2.18	80000	PL254012C - M --- 1.5 A	90	-	13.7	
	0.97	1468.13	14119	1.52	80000	PL254014C - M --- 1.5 A	90	-	13.7	
	0.82	1746.69	16798	1.29	80000	PL254018C - M --- 1.5 A	90	-	13.6	
	0.68	2099.39	20189	0.82	80000	PL254020C - M --- 1.5 A	90	-	13.5	
	1.03	1414.11	13691	3.41	110000	PL404014C - M --- 1.5 A	90	-	17.6	
	0.81	1793.64	17365	2.02	110000	PL404018C - M --- 1.5 A	90	-	17.5	
	0.69	2105.39	20384	1.46	110000	PL404020C - M --- 1.5 A	90	-	17.5	
	2.2 kW	65.2	22.22	312	2.69	11217	PL012022. - M --- 2.2 A	100	9.1	8.2
		60.1	24.11	339	3.07	12170	PL012025. - M --- 2.2 A	100	9.1	8.2
		49.7	29.17	410	2.57	14721	PL012028. - M --- 2.2 A	100	8.8	8.0
		41.0	35.36	497	1.74	15000	PL012036. - M --- 2.2 A	100	8.6	7.8
		37.7	38.44	540	1.12	15000	PL012040. - M --- 2.2 A	100	8.5	7.7
		31.2	46.50	654	0.94	15000	PL012045. - M --- 2.2 A	100	8.4	7.5
24.7		58.81	818	1.35	15000	PL013063. - M --- 2.2 A	100	6.9	6.4	
20.3		71.30	992	1.12	15000	PL013071. - M --- 2.2 A	100	6.9	6.3	
16.8		86.43	1202	0.94	15000	PL013080. - M --- 2.2 A	100	6.8	6.2	
15.5		93.77	1304	0.87	15000	PL013090. - M --- 2.2 A	100	6.8	6.2	
41.0		35.36	497	3.21	15000	PL022036. - M --- 2.2 A	100	9.4	8.5	
37.7		38.44	540	2.08	15000	PL022040. - M --- 2.2 A	100	9.3	8.4	
31.2		46.50	654	1.74	15000	PL022045. - M --- 2.2 A	100	9.1	8.2	
25.8		56.25	791	1.07	15000	PL022056. - M --- 2.2 A	100	8.9	8.0	
24.7		58.81	818	2.48	15000	PL023063. - M --- 2.2 A	100	7.1	6.5	
20.3		71.30	992	2.07	15000	PL023071. - M --- 2.2 A	100	7.1	6.5	
16.8		86.43	1202	1.73	15000	PL023080. - M --- 2.2 A	100	7.0	6.4	
15.5		93.77	1304	1.60	15000	PL023090. - M --- 2.2 A	100	7.0	6.4	
13.8		104.77	1457	1.17	15000	PL0230100 - M --- 2.2 A	100	6.9	6.4	
12.8		113.43	1578	1.34	15000	PL0230112 - M --- 2.2 A	100	6.9	6.3	
10.5		137.50	1913	1.12	15000	PL0230125 - M --- 2.2 A	100	6.8	6.3	
9.7		149.49	2079	1.04	15000	PL0230140 - M --- 2.2 A	100	6.8	6.3	
34.4		42.19	593	3.29	44500	PL032045. - M --- 2.2 A	100	13.5	13.0	
28.9		50.19	705	2.08	44500	PL032050. - M --- 2.2 A	100	13.3	12.7	
26.3		55.09	766	4.38	44500	PL033056. - M --- 2.2 A	100	10.2	9.8	
21.7		66.79	929	3.66	44500	PL033071. - M --- 2.2 A	100	10.1	9.7	
17.9		80.96	1126	3.05	44500	PL033080. - M --- 2.2 A	100	10.0	9.7	
16.5		87.83	1222	2.83	44500	PL033090. - M --- 2.2 A	100	10.0	9.6	
15.0		96.98	1349	2.19	44500	PL0330100 - M --- 2.2 A	100	10.0	9.6	

SERIES P

PL MOTORISED RATINGS

	N2	Ratio <i>i</i>	M2 (NM)	fm	FR2 (N)	Unit Designation	Motor Frame	PT(kW) Type B	PT (kW) Type F
2.2 kW 4 - Pole	13.6	106.48	1481	2.36	44500	PL0330112 - M --- 2.2 A	100	9.9	9.5
	11.3	128.80	1792	1.98	44500	PL0330125 - M --- 2.2 A	100	9.8	9.4
	10.4	140.03	1948	1.83	44500	PL0330140 - M --- 2.2 A	100	9.8	9.4
	9.4	154.29	2146	1.42	44500	PL0330160 - M --- 2.2 A	100	9.7	9.4
	8.6	169.39	2356	1.53	44500	PL0330180 - M --- 2.2 A	100	9.7	9.3
	7.1	204.91	2850	1.28	44500	PL0330200 - M --- 2.2 A	100	9.6	9.2
	5.9	245.45	3414	0.92	44500	PL0330250 - M --- 2.2 A	100	9.5	9.2
	5.6	259.72	3613	1.02	44500	PL0340250 - M --- 2.2 A	100	8.0	7.7
	4.6	314.85	4380	0.86	44500	PL0340315 - M --- 2.2 A	100	7.9	7.6
	13.6	106.48	1481	3.63	44500	PL0530112 - M --- 2.2 A	100	10.4	10.0
11.3	128.80	1792	3.04	44500	PL0530125 - M --- 2.2 A	100	10.3	9.9	
10.4	140.03	1948	2.81	44500	PL0530140 - M --- 2.2 A	100	10.3	9.9	
9.4	154.29	2146	2.18	44500	PL0530160 - M --- 2.2 A	100	10.2	9.8	
8.6	169.39	2356	2.35	44500	PL0530180 - M --- 2.2 A	100	10.2	9.8	
7.1	204.91	2850	1.97	44500	PL0530200 - M --- 2.2 A	100	10.1	9.7	
5.9	245.45	3414	1.41	44500	PL0530250 - M --- 2.2 A	100	10.0	9.6	
5.5	261.56	3638	0.92	44500	PL0530280 - M --- 2.2 A	100	10.0	9.6	
5.6	259.72	3575	1.59	44500	PL0540250 - M --- 2.2 A	100	8.4	8.1	
4.6	314.85	4334	1.33	44500	PL0540315 - M --- 2.2 A	100	8.2	7.9	
4.2	341.57	4702	1.23	44500	PL0540360 - M --- 2.2 A	100	7.8	7.6	
3.5	413.19	5688	1.03	44500	PL0540400 - M --- 2.2 A	100	7.6	7.4	
2.9	500.89	6895	0.86	44500	PL0540500 - M --- 2.2 A	100	7.6	7.3	
2.7	544.57	7496	0.80	44500	PL0540560 - M --- 2.2 A	100	7.6	7.3	
7.9	182.84	2543	3.81	52000	PL0830180 - M --- 2.2 A	100	15.0	14.1	
6.6	219.02	3047	2.77	52000	PL0830225 - M --- 2.2 A	100	14.9	14.0	
6.1	237.30	3301	1.77	52000	PL0830250 - M --- 2.2 A	100	14.9	13.9	
5.1	282.33	3927	1.50	52000	PL0830280 - M --- 2.2 A	100	14.7	13.8	
6.0	243.29	3349	2.95	52000	PL0840250 - M --- 2.2 A	100	11.7	11.0	
4.9	294.93	4060	2.46	52000	PL0840315 - M --- 2.2 A	100	11.5	10.8	
4.5	319.96	4404	2.28	52000	PL0840360 - M --- 2.2 A	100	11.1	10.4	
3.7	387.05	5328	1.91	52000	PL0840400 - M --- 2.2 A	100	10.8	10.2	
3.1	469.20	6459	1.59	52000	PL0840450 - M --- 2.2 A	100	10.8	10.1	
2.8	510.11	7022	1.47	52000	PL0840500 - M --- 2.2 A	100	10.8	10.1	
2.6	562.04	7737	1.35	52000	PL0840560 - M --- 2.2 A	100	10.7	10.1	
2.3	617.07	8494	1.23	52000	PL0840630 - M --- 2.2 A	100	10.7	10.1	
1.9	746.46	10275	1.03	52000	PL0840710 - M --- 2.2 A	100	10.6	10.0	
1.8	787.68	10843	0.98	52000	PL0840800 - M --- 2.2 A	100	10.6	10.0	
1.6	894.16	12308	0.87	52000	PL0840900 - M --- 2.2 A	100	10.6	10.0	
6.6	219.02	3047	3.53	52000	PL1230225 - M --- 2.2 A	100	15.8	14.9	
6.1	237.30	3301	2.36	52000	PL1230250 - M --- 2.2 A	100	15.7	14.8	
5.1	282.33	3927	2.01	52000	PL1230280 - M --- 2.2 A	100	15.6	14.7	
4.3	335.90	4672	1.44	52000	PL1230360 - M --- 2.2 A	100	15.5	14.6	
6.0	243.29	3349	3.65	52000	PL1240250 - M --- 2.2 A	100	12.3	11.6	
4.9	294.93	4060	3.05	52000	PL1240315 - M --- 2.2 A	100	12.1	11.4	
4.5	319.96	4404	2.82	52000	PL1240360 - M --- 2.2 A	100	11.8	11.1	
3.7	387.05	5328	2.36	52000	PL1240400 - M --- 2.2 A	100	11.5	10.8	
3.1	469.20	6459	1.97	52000	PL1240450 - M --- 2.2 A	100	11.4	10.7	
2.8	510.11	7022	1.82	52000	PL1240500 - M --- 2.2 A	100	11.4	10.7	
2.6	562.04	7737	1.67	52000	PL1240560 - M --- 2.2 A	100	11.3	10.7	
2.3	617.07	8494	1.53	52000	PL1240630 - M --- 2.2 A	100	11.3	10.7	
1.9	746.46	10275	1.28	52000	PL1240710 - M --- 2.2 A	100	11.3	10.6	
1.8	787.68	10843	1.21	52000	PL1240800 - M --- 2.2 A	100	11.2	10.6	
1.6	894.16	12308	1.08	52000	PL1240900 - M --- 2.2 A	100	11.2	10.6	
1.5	952.83	13116	1.02	52000	PL124010C - M --- 2.2 A	100	11.2	10.5	
1.3	1152.62	15866	0.85	52000	PL124011C - M --- 2.2 A	100	11.1	10.5	
6.0	242.60	3375	4.15	54000	PL1630250 - M --- 2.2 A	100	27.4	18.9	
5.1	284.77	3961	2.21	54000	PL1630280 - M --- 2.2 A	100	27.1	18.7	
4.3	338.80	4713	1.88	54000	PL1630315 - M --- 2.2 A	100	26.9	18.6	
4.3	340.35	4685	3.91	54000	PL1640360 - M --- 2.2 A	100	19.4	13.5	
3.5	411.72	5667	3.27	54000	PL1640400 - M --- 2.2 A	100	19.4	13.5	
2.9	499.10	6870	2.73	54000	PL1640500 - M --- 2.2 A	100	19.3	13.5	
2.7	542.62	7469	2.52	54000	PL1640560 - M --- 2.2 A	100	19.3	13.4	
2.4	597.86	8230	2.31	54000	PL1640630 - M --- 2.2 A	100	19.2	13.4	
2.2	656.40	9035	2.11	54000	PL1640710 - M --- 2.2 A	100	19.2	13.4	
1.8	794.03	10930	1.77	54000	PL1640800 - M --- 2.2 A	100	19.1	13.3	
1.5	951.14	13093	1.49	54000	PL1640900 - M --- 2.2 A	100	19.0	13.2	
1.4	1013.55	13952	1.41	54000	PL164010C - M --- 2.2 A	100	18.9	13.2	
1.2	1226.07	16877	1.18	54000	PL164012C - M --- 2.2 A	100	18.9	13.1	
1.0	1458.71	20079	1.00	54000	PL164014C - M --- 2.2 A	100	18.8	13.1	
3.0	476.88	6564	4.02	80000	PL2540450 - M --- 2.2 A	100	-	14.1	
2.9	508.18	6995	3.79	80000	PL2540500 - M --- 2.2 A	100	-	14.1	
2.4	614.73	8462	3.17	80000	PL2540630 - M --- 2.2 A	100	-	14.0	
2.0	731.37	10067	2.69	80000	PL2540710 - M --- 2.2 A	100	-	13.9	
1.8	784.69	10801	2.52	80000	PL2540800 - M --- 2.2 A	100	-	13.9	
1.7	876.08	12059	2.28	80000	PL2540900 - M --- 2.2 A	100	-	13.8	
1.5	949.22	13066	2.11	80000	PL254010C - M --- 2.2 A	100	-	13.8	

SERIES P

PL MOTORISED RATINGS

	N2	Ratio <i>i</i>	M2 (NM)	fm	FR2 (N)	Unit Designation	Motor Frame	PT(kW) Type B	PT (kW) Type F	
2.2 kW	1.1	1343.61	18495	1.52	80000	PL254012C - M --- 2.2 A	100	-	13.7	
	1.0	1468.13	20209	1.06	80000	PL254014C - M --- 2.2 A	100	-	13.7	
4 - Pole	2.0	715.45	10159	3.26	110000	PL4040710 - M --- 2.2 A	100	-	18.0	
	1.7	851.09	12085	3.74	110000	PL4040800 - M --- 2.2 A	100	-	17.9	
	1.7	865.46	12289	2.73	110000	PL4040900 - M --- 2.2 A	100	-	17.9	
	1.4	1012.58	14378	3.18	110000	PL404010C - M --- 2.2 A	100	-	17.8	
	1.2	1188.59	16878	2.73	110000	PL404012C - M --- 2.2 A	100	-	17.7	
	1.0	1414.11	20080	2.32	110000	PL404014C - M --- 2.2 A	100	-	17.6	
	0.8	1793.64	25469	1.38	110000	PL404018C - M --- 2.2 A	100	-	17.5	
	0.7	2105.39	29896	1.00	110000	PL404020C - M --- 2.2 A	100	-	17.5	
	3.0 kW	79.1	18.33	351	2.89	9253	PL012018. - M --- 3.0 A	100	9.4	8.5
		65.2	22.22	426	1.97	11217	PL012022. - M --- 3.0 A	100	9.1	8.2
60.1		24.11	462	2.25	12170	PL012025. - M --- 3.0 A	100	9.1	8.2	
49.7		29.17	559	1.88	14721	PL012028. - M --- 3.0 A	100	8.8	8.0	
41.0		35.36	678	1.28	15000	PL012036. - M --- 3.0 A	100	8.6	7.8	
37.7		38.44	737	0.82	15000	PL012040. - M --- 3.0 A	100	8.5	7.7	
49.7		29.17	559	3.48	14721	PL022028. - M --- 3.0 A	100	9.8	8.9	
41.0		35.36	678	2.35	15000	PL022036. - M --- 3.0 A	100	9.6	8.7	
37.7		38.44	737	1.52	15000	PL022040. - M --- 3.0 A	100	9.4	8.5	
31.2		46.50	891	1.27	15000	PL022045. - M --- 3.0 A	100	9.3	8.4	
25.8	56.25	1078	0.78	15000	PL022056. - M --- 3.0 A	100	9.1	8.2		
24.7	58.81	1116	1.82	15000	PL023063. - M --- 3.0 A	100	7.1	6.5		
20.3	71.30	1352	1.52	15000	PL023071. - M --- 3.0 A	100	7.1	6.5		
16.8	86.43	1639	1.27	15000	PL023080. - M --- 3.0 A	100	7.1	6.5		
15.5	93.77	1779	1.18	15000	PL023090. - M --- 3.0 A	100	7.1	6.5		
13.8	104.77	1987	0.86	15000	PL0230100 - M --- 3.0 A	100	7.1	6.5		
12.8	113.43	2151	0.98	15000	PL0230112 - M --- 3.0 A	100	7.1	6.5		
10.5	137.50	2608	0.82	15000	PL0230125 - M --- 3.0 A	100	7.1	6.5		
41.6	34.88	668	2.88	44500	PL032036. - M --- 3.0 A	100	13.8	13.3		
34.4	42.19	809	2.41	44500	PL032045. - M --- 3.0 A	100	13.5	13.0		
28.9	50.19	962	1.52	44500	PL032050. - M --- 3.0 A	100	13.3	12.7		
26.3	55.09	1045	3.21	44500	PL033056. - M --- 3.0 A	100	10.2	9.8		
21.7	66.79	1267	2.68	44500	PL033071. - M --- 3.0 A	100	10.1	9.7		
17.9	80.96	1536	2.24	44500	PL033080. - M --- 3.0 A	100	10.0	9.7		
16.5	87.83	1666	2.07	44500	PL033090. - M --- 3.0 A	100	10.0	9.6		
15.0	96.98	1840	1.61	44500	PL0330100 - M --- 3.0 A	100	10.0	9.6		
13.6	106.48	2020	1.73	44500	PL0330112 - M --- 3.0 A	100	9.9	9.5		
11.3	128.80	2443	1.45	44500	PL0330125 - M --- 3.0 A	100	9.8	9.4		
10.4	140.03	2656	1.34	44500	PL0330140 - M --- 3.0 A	100	9.8	9.4		
9.4	154.29	2927	1.04	44500	PL0330160 - M --- 3.0 A	100	9.7	9.4		
8.6	169.39	3213	1.12	44500	PL0330180 - M --- 3.0 A	100	9.7	9.3		
7.1	204.91	3887	0.94	44500	PL0330200 - M --- 3.0 A	100	9.6	9.2		
17.9	80.96	1536	3.45	44500	PL053080. - M --- 3.0 A	100	10.5	10.1		
16.5	87.83	1666	3.19	44500	PL053090. - M --- 3.0 A	100	10.5	10.1		
15.0	96.98	1840	2.47	44500	PL0530100 - M --- 3.0 A	100	10.4	10.1		
13.6	106.48	2020	2.67	44500	PL0530112 - M --- 3.0 A	100	10.4	10.0		
11.3	128.80	2443	2.23	44500	PL0530125 - M --- 3.0 A	100	10.3	9.9		
10.4	140.03	2656	2.06	44500	PL0530140 - M --- 3.0 A	100	10.3	9.9		
9.4	154.29	2927	1.60	44500	PL0530160 - M --- 3.0 A	100	10.2	9.8		
8.6	169.39	3213	1.73	44500	PL0530180 - M --- 3.0 A	100	10.2	9.8		
7.1	204.91	3887	1.44	44500	PL0530200 - M --- 3.0 A	100	10.1	9.7		
5.9	245.45	4656	1.03	44500	PL0530250 - M --- 3.0 A	100	10.0	9.6		
5.6	259.72	4926	1.16	44500	PL0540250 - M --- 3.0 A	100	8.4	8.1		
4.6	314.85	5972	0.97	44500	PL0540315 - M --- 3.0 A	100	8.2	7.9		
4.2	341.57	6479	0.89	44500	PL0540360 - M --- 3.0 A	100	7.8	7.6		
12.2	119.22	2261	4.18	52000	PL0830112 - M --- 3.0 A	100	15.4	14.4		
11.4	127.04	2410	3.93	52000	PL0830125 - M --- 3.0 A	100	15.3	14.3		
10.2	142.81	2709	3.03	52000	PL0830140 - M --- 3.0 A	100	15.2	14.3		
9.4	153.68	2915	3.29	52000	PL0830160 - M --- 3.0 A	100	15.2	14.2		
7.9	182.84	3468	2.80	52000	PL0830180 - M --- 3.0 A	100	15.0	14.1		
6.6	219.02	4154	2.03	52000	PL0830225 - M --- 3.0 A	100	14.9	14.0		
6.1	237.30	4501	1.30	52000	PL0830250 - M --- 3.0 A	100	14.9	13.9		
5.1	282.33	5355	1.10	52000	PL0830280 - M --- 3.0 A	100	14.7	13.8		
4.3	335.90	6371	0.79	52000	PL0830360 - M --- 3.0 A	100	14.6	13.7		
6.0	243.29	4615	2.14	52000	PL0840250 - M --- 3.0 A	100	11.7	11.0		
4.9	294.93	5594	1.79	52000	PL0840315 - M --- 3.0 A	100	11.5	10.8		
4.5	319.96	6069	1.66	52000	PL0840360 - M --- 3.0 A	100	11.1	10.4		
3.7	387.05	7342	1.39	52000	PL0840400 - M --- 3.0 A	100	10.8	10.2		
3.1	469.20	8900	1.16	52000	PL0840450 - M --- 3.0 A	100	10.8	10.1		
2.8	510.11	9676	1.07	52000	PL0840500 - M --- 3.0 A	100	10.8	10.1		
2.6	562.04	10661	0.98	52000	PL0840560 - M --- 3.0 A	100	10.7	10.1		
2.3	617.07	11705	0.89	52000	PL0840630 - M --- 3.0 A	100	10.7	10.1		
9.4	153.68	2915	4.07	52000	PL1230160 - M --- 3.0 A	100	16.1	15.1		
7.9	182.84	3468	3.46	52000	PL1230180 - M --- 3.0 A	100	15.9	15.0		
6.6	219.02	4154	2.59	52000	PL1230225 - M --- 3.0 A	100	15.8	14.9		

PL MOTORISED RATINGS

	N2	Ratio <i>i</i>	M2 (NM)	fm	FR2 (N)	Unit Designation	Motor Frame	PT(kW) Type B	PT (kW) Type F
3.0 kW 4 - Pole	6.1	237.30	4501	1.73	52000	PL1230250 - M --- 3.0 A	100	15.7	14.8
	5.1	282.33	5355	1.47	52000	PL1230280 - M --- 3.0 A	100	15.6	14.7
	4.3	335.90	6371	1.06	52000	PL1230360 - M --- 3.0 A	100	15.5	14.6
	6.0	243.29	4567	2.68	52000	PL1240250 - M --- 3.0 A	100	12.3	11.6
	4.9	294.93	5536	2.24	52000	PL1240315 - M --- 3.0 A	100	12.1	11.4
	4.5	319.96	6006	2.07	52000	PL1240360 - M --- 3.0 A	100	11.8	11.1
	3.7	387.05	7265	1.73	52000	PL1240400 - M --- 3.0 A	100	11.5	10.8
	3.1	469.20	8807	1.45	52000	PL1240450 - M --- 3.0 A	100	11.4	10.7
	2.8	510.11	9575	1.34	52000	PL1240500 - M --- 3.0 A	100	11.4	10.7
	2.6	562.04	10550	1.22	52000	PL1240560 - M --- 3.0 A	100	11.3	10.7
	2.3	617.07	11583	1.12	52000	PL1240630 - M --- 3.0 A	100	11.3	10.7
	1.9	746.46	14012	0.94	52000	PL1240710 - M --- 3.0 A	100	11.3	10.6
	1.8	787.68	14785	0.89	52000	PL1240800 - M --- 3.0 A	100	11.2	10.6
	7.1	203.91	3868	3.58	54000.0	PL1630225 - M --- 3.0 A	100	27.6	19.0
	6.0	242.60	4602	3.04	54000.0	PL1630250 - M --- 3.0 A	100	27.4	18.9
	5.1	284.77	5402	1.62	54000.0	PL1630280 - M --- 3.0 A	100	27.1	18.7
	4.3	338.80	6426	1.38	54000.0	PL1630315 - M --- 3.0 A	100	26.9	18.6
	5.6	258.79	4858	3.71	54000.0	PL1640280 - M --- 3.0 A	100	21.4	14.9
	4.6	313.72	5889	3.09	54000.0	PL1640315 - M --- 3.0 A	100	19.7	13.7
	4.3	340.35	6389	2.87	54000.0	PL1640360 - M --- 3.0 A	100	19.4	13.5
	3.5	411.72	7728	2.40	54000.0	PL1640400 - M --- 3.0 A	100	19.4	13.5
	2.9	499.10	9369	2.00	54000.0	PL1640500 - M --- 3.0 A	100	19.3	13.5
	2.7	542.62	10185	1.85	54000.0	PL1640560 - M --- 3.0 A	100	19.3	13.4
	2.4	597.86	11222	1.69	54000.0	PL1640630 - M --- 3.0 A	100	19.2	13.4
	2.2	656.40	12321	1.55	54000.0	PL1640710 - M --- 3.0 A	100	19.2	13.4
	1.8	794.03	14904	1.30	54000.0	PL1640800 - M --- 3.0 A	100	19.1	13.3
	1.5	951.14	17853	1.09	54000.0	PL1640900 - M --- 3.0 A	100	19.0	13.2
	1.4	1013.55	19025	1.03	54000.0	PL164010C - M --- 3.0 A	100	18.9	13.2
	1.2	1226.07	23014	0.86	54000.0	PL164012C - M --- 3.0 A	100	18.9	13.1
	4.4	329.1	6178	4.18	80000	PL2540315 - M --- 3.0 A	100	-	14.2
	4.0	359.1	6740	3.85	80000	PL2540360 - M --- 3.0 A	100	-	14.2
	3.6	398.1	7473	3.49	80000	PL2540400 - M --- 3.0 A	100	-	14.2
	3.0	476.9	8951	2.95	80000	PL2540450 - M --- 3.0 A	100	-	14.1
	2.9	508.2	9539	2.78	80000	PL2540500 - M --- 3.0 A	100	-	14.1
	2.4	614.7	11539	2.33	80000	PL2540630 - M --- 3.0 A	100	-	14.0
	2.0	731.4	13728	1.98	80000	PL2540710 - M --- 3.0 A	100	-	13.9
	1.8	784.7	14729	1.85	80000	PL2540800 - M --- 3.0 A	100	-	13.9
	1.7	876.1	16445	1.67	80000	PL2540900 - M --- 3.0 A	100	-	13.8
	1.5	949.2	17817	1.55	80000	PL254010C - M --- 3.0 A	100	-	13.8
	1.3	1129.3	21198	1.32	80000	PL254011C - M --- 3.0 A	100	-	13.7
	1.1	1343.6	25220	1.12	80000	PL254012C - M --- 3.0 A	100	-	13.7
	1.0	1468.1	27558	0.78	80000	PL254014C - M --- 3.0 A	100	-	13.7
	2.1	682.34	13212	3.37	110000	PL4040630 - M --- 3.0 A	100	-	18.0
	2.0	715.45	13854	2.39	110000	PL4040710 - M --- 3.0 A	100	-	18.0
	1.7	851.09	16480	2.74	110000	PL4040800 - M --- 3.0 A	100	-	17.9
	1.7	865.46	16758	2.00	110000	PL4040900 - M --- 3.0 A	100	-	17.9
	1.4	1012.58	19607	2.33	110000	PL404010C - M --- 3.0 A	100	-	17.8
1.2	1188.59	23015	2.00	110000	PL404012C - M --- 3.0 A	100	-	17.7	
1.0	1414.11	27382	1.70	110000	PL404014C - M --- 3.0 A	100	-	17.6	
0.8	1793.64	34731	1.01	110000	PL404018C - M --- 3.0 A	100	-	17.5	
4.0 kW 4 - Pole	95.9	15.12	386	2.48	7633	PL012016. - M --- 4.0 A	112	9.6	8.7
	79.1	18.33	468	2.17	9253	PL012018. - M --- 4.0 A	112	9.4	8.5
	65.2	22.22	568	1.48	11217	PL012022. - M --- 4.0 A	112	9.6	8.7
	60.1	24.11	616	1.69	12170	PL012025. - M --- 4.0 A	112	9.4	8.5
	49.7	29.17	745	1.41	14721	PL012028. - M --- 4.0 A	112	9.1	8.2
	41.0	35.36	904	0.96	15000	PL012036. - M --- 4.0 A	112	9.1	8.2
	79.1	18.33	468	3.71	9253	PL022018. - M --- 4.0 A	112	10.2	9.2
	65.2	22.22	568	2.73	11217	PL022022. - M --- 4.0 A	112	9.9	9.0
	60.1	24.11	616	3.07	12170	PL022025. - M --- 4.0 A	112	9.8	8.9
	49.7	29.17	745	2.61	14721	PL022028. - M --- 4.0 A	112	9.6	8.7
	41.0	35.36	904	1.76	15000	PL022036. - M --- 4.0 A	112	9.4	8.5
	37.7	38.44	982	1.14	15000	PL022040. - M --- 4.0 A	112	9.3	8.4
	31.2	46.50	1188	0.96	15000	PL022045. - M --- 4.0 A	112	9.1	8.2
	24.7	58.81	1487	1.37	15000	PL023063. - M --- 4.0 A	112	7.1	6.5
	20.3	71.30	1803	1.14	15000	PL023071. - M --- 4.0 A	112	7.1	6.5
	16.8	86.43	2186	0.95	15000	PL023080. - M --- 4.0 A	112	7.0	6.4
	15.5	93.77	2371	0.88	15000	PL023090. - M --- 4.0 A	112	7.0	6.4
	44.3	32.73	836	3.30	44500	PL032032. - M --- 4.0 A	112	14.0	13.4
	41.6	34.88	891	2.16	44500	PL032036. - M --- 4.0 A	112	13.8	13.3
	34.4	42.19	1078	1.81	44500	PL032045. - M --- 4.0 A	112	13.5	13.0
	28.9	50.19	1283	1.14	44500	PL032050. - M --- 4.0 A	112	13.3	12.7
	26.3	55.09	1393	2.41	44500	PL033056. - M --- 4.0 A	112	10.2	9.8
	21.7	66.79	1689	2.01	44500	PL033071. - M --- 4.0 A	112	10.1	9.7
	17.9	80.96	2048	1.68	44500	PL033080. - M --- 4.0 A	112	10.0	9.7
	16.5	87.83	2221	1.56	44500	PL033090. - M --- 4.0 A	112	10.0	9.6
	15.0	96.98	2453	1.20	44500	PL0330100 - M --- 4.0 A	112	10.0	9.6

SERIES P

PL MOTORISED RATINGS

	N2	Ratio <i>i</i>	M2 (NM)	fm	FR2 (N)	Unit Designation	Motor Frame	PT(kW) Type B	PT (kW) Type F
4.0 kW 4 - Pole	13.6	106.48	2693	1.30	44500	PL0330112 - M --- 4.0 A	112	9.9	9.5
	11.3	128.80	3258	1.09	44500	PL0330125 - M --- 4.0 A	112	9.8	9.4
	10.4	140.03	3542	1.01	44500	PL0330140 - M --- 4.0 A	112	9.8	9.4
	9.4	154.29	3902	0.78	44500	PL0330160 - M --- 4.0 A	112	9.7	9.4
	26.3	55.09	1393	3.71	44500	PL053056. - M --- 4.0 A	112	10.7	10.3
	21.7	66.79	1689	3.09	44500	PL053071. - M --- 4.0 A	112	10.6	10.2
	17.9	80.96	2048	2.58	44500	PL053080. - M --- 4.0 A	112	10.7	10.3
	16.5	87.83	2221	2.39	44500	PL053090. - M --- 4.0 A	112	10.7	10.3
	15.0	96.98	2453	1.85	44500	PL0530100 - M --- 4.0 A	112	10.7	10.3
	13.6	106.48	2693	2.00	44500	PL0530112 - M --- 4.0 A	112	10.7	10.3
11.3	128.80	3258	1.67	44500	PL0530125 - M --- 4.0 A	112	10.7	10.3	
10.4	140.03	3542	1.55	44500	PL0530140 - M --- 4.0 A	112	10.7	10.3	
9.4	154.29	3902	1.20	44500	PL0530160 - M --- 4.0 A	112	10.7	10.3	
8.6	169.39	4284	1.29	44500	PL0530180 - M --- 4.0 A	112	10.7	10.3	
7.1	204.91	5182	1.08	44500	PL0530200 - M --- 4.0 A	112	10.7	10.3	
16.2	89.77	2270	3.52	52000	PL083090. - M --- 4.0 A	112	15.6	14.6	
14.7	98.56	2493	3.74	52000	PL0830100 - M --- 4.0 A	112	15.5	14.5	
12.2	119.22	3015	3.13	52000	PL0830112 - M --- 4.0 A	112	15.4	14.4	
11.4	127.04	3213	2.95	52000	PL0830125 - M --- 4.0 A	112	15.3	14.3	
10.2	142.81	3612	2.28	52000	PL0830140 - M --- 4.0 A	112	15.2	14.3	
9.4	153.68	3887	2.47	52000	PL0830160 - M --- 4.0 A	112	15.2	14.2	
7.9	182.84	4624	2.10	52000	PL0830180 - M --- 4.0 A	112	15.0	14.1	
6.6	219.02	5539	1.52	52000	PL0830225 - M --- 4.0 A	112	14.9	14.0	
6.1	237.30	6002	0.97	52000	PL0830250 - M --- 4.0 A	112	14.9	13.9	
5.1	282.33	7140	0.83	52000	PL0830280 - M --- 4.0 A	112	14.7	13.8	
6.0	243.29	6153	1.61	52000	PL0840250 - M --- 4.0 A	112	11.7	11.0	
4.9	294.93	7459	1.34	52000	PL0840315 - M --- 4.0 A	112	11.5	10.8	
4.5	319.96	8092	1.24	52000	PL0840360 - M --- 4.0 A	112	11.1	10.4	
3.7	387.05	9789	1.04	52000	PL0840400 - M --- 4.0 A	112	10.8	10.2	
3.1	469.20	11867	0.87	52000	PL0840450 - M --- 4.0 A	112	10.8	10.1	
2.8	510.11	12901	0.80	52000	PL0840500 - M --- 4.0 A	112	10.8	10.1	
12.2	119.22	3015	3.88	52000	PL1230112 - M --- 4.0 A	112	16.3	15.3	
11.4	127.04	3213	3.65	52000	PL1230125 - M --- 4.0 A	112	16.2	15.3	
10.2	142.81	3612	2.90	52000	PL1230140 - M --- 4.0 A	112	16.1	15.2	
9.4	153.68	3887	3.06	52000	PL1230160 - M --- 4.0 A	112	16.1	15.1	
7.9	182.84	4624	2.60	52000	PL1230180 - M --- 4.0 A	112	15.9	15.0	
6.6	219.02	5539	1.94	52000	PL1230225 - M --- 4.0 A	112	15.8	14.9	
6.1	237.30	6002	1.30	52000	PL1230250 - M --- 4.0 A	112	15.7	14.8	
5.1	282.33	7140	1.10	52000	PL1230280 - M --- 4.0 A	112	15.6	14.7	
6.0	243.29	6089	2.01	52000	PL1240250 - M --- 4.0 A	112	12.3	11.6	
4.9	294.93	7381	1.68	52000	PL1240315 - M --- 4.0 A	112	12.1	11.4	
4.5	319.96	8008	1.55	52000	PL1240360 - M --- 4.0 A	112	11.8	11.1	
3.7	387.05	9687	1.30	52000	PL1240400 - M --- 4.0 A	112	11.5	10.8	
3.1	469.20	11743	1.09	52000	PL1240450 - M --- 4.0 A	112	11.4	10.7	
2.8	510.11	12767	1.00	52000	PL1240500 - M --- 4.0 A	112	11.4	10.7	
2.6	562.04	14067	0.92	52000	PL1240560 - M --- 4.0 A	112	11.3	10.7	
2.3	617.07	15444	0.84	52000	PL1240630 - M --- 4.0 A	112	11.3	10.7	
7.5	194.50	4919	3.59	54000	PL1630200 - M --- 4.0 A	112	27.7	19.1	
7.1	203.91	5157	2.68	54000	PL1630225 - M --- 4.0 A	112	27.6	19.0	
6.0	242.60	6136	2.28	54000	PL1630250 - M --- 4.0 A	112	27.4	18.9	
5.1	284.77	7202	1.22	54000	PL1630280 - M --- 4.0 A	112	27.1	18.7	
4.3	338.80	8569	1.03	54000	PL1630315 - M --- 4.0 A	112	26.9	18.6	
6.8	213.48	5343	3.33	54000	PL1640225 - M --- 4.0 A	112	21.4	14.9	
5.6	258.79	6477	2.78	54000	PL1640280 - M --- 4.0 A	112	21.4	14.9	
4.6	313.72	7852	2.32	54000	PL1640315 - M --- 4.0 A	112	19.7	13.7	
4.3	340.35	8518	2.15	54000	PL1640360 - M --- 4.0 A	112	19.4	13.5	
3.5	411.72	10304	1.80	54000	PL1640400 - M --- 4.0 A	112	19.4	13.5	
2.9	499.10	12491	1.50	54000	PL1640500 - M --- 4.0 A	112	19.3	13.5	
2.7	542.62	13581	1.39	54000	PL1640560 - M --- 4.0 A	112	19.3	13.4	
2.4	597.86	14963	1.27	54000	PL1640630 - M --- 4.0 A	112	19.2	13.4	
2.2	656.40	16428	1.16	54000	PL1640710 - M --- 4.0 A	112	19.2	13.4	
1.8	794.03	19873	0.97	54000	PL1640800 - M --- 4.0 A	112	19.1	13.3	
1.5	951.14	23805	0.82	54000	PL1640900 - M --- 4.0 A	112	19.0	13.2	
5.8	250.24	6263	4.05	80000	PL2540250 - M --- 4.0 A	112	-	15.6	
4.8	299.76	7502	3.42	80000	PL2540280 - M --- 4.0 A	112	-	14.6	
4.4	329.11	8237	3.13	80000	PL2540315 - M --- 4.0 A	112	-	14.2	
4.0	359.06	8987	2.89	80000	PL2540360 - M --- 4.0 A	112	-	14.2	
3.6	398.11	9964	2.62	80000	PL2540400 - M --- 4.0 A	112	-	14.2	
3.0	476.88	11935	2.21	80000	PL2540450 - M --- 4.0 A	112	-	14.1	
2.9	508.18	12718	2.08	80000	PL2540500 - M --- 4.0 A	112	-	14.1	
2.4	614.73	15385	1.74	80000	PL2540630 - M --- 4.0 A	112	-	14.0	
2.0	731.37	18305	1.48	80000	PL2540710 - M --- 4.0 A	112	-	13.9	
1.8	784.69	19639	1.39	80000	PL2540800 - M --- 4.0 A	112	-	13.9	
1.7	876.08	21926	1.25	80000	PL2540900 - M --- 4.0 A	112	-	13.8	
1.5	949.22	23757	1.16	80000	PL254010C - M --- 4.0 A	112	-	13.8	
1.3	1129.33	28264	0.99	80000	PL254011C - M --- 4.0 A	112	-	13.7	
1.1	1343.61	33627	0.84	80000	PL254012C - M --- 4.0 A	112	-	13.7	

PL MOTORISED RATINGS

	N2	Ratio <i>i</i>	M2 (NM)	fm	FR2 (N)	Unit Designation	Motor Frame	PT(kW) Type B	PT (kW) Type F
4.0 kW 4 - Pole	3.3	441.89	11409	3.80	110000	PL4040400 - M --- 4.0 A	112	-	18.2
	3.2	455.64	11764	3.69	110000	PL4040450 - M --- 4.0 A	112	-	18.2
	2.7	529.33	13666	3.21	110000	PL4040500 - M --- 4.0 A	112	-	18.1
	2.6	564.07	14563	3.02	110000	PL4040560 - M --- 4.0 A	112	-	18.1
	2.1	682.34	17617	2.53	110000	PL4040630 - M --- 4.0 A	112	-	18.0
	2.0	715.45	18471	1.79	110000	PL4040710 - M --- 4.0 A	112	-	18.0
	1.7	851.09	21973	2.06	110000	PL4040800 - M --- 4.0 A	112	-	17.9
	1.7	865.46	22344	1.50	110000	PL4040900 - M --- 4.0 A	112	-	17.9
	1.4	1012.58	26143	1.75	110000	PL404010C - M --- 4.0 A	112	-	17.8
	1.2	1188.59	30687	1.50	110000	PL404012C - M --- 4.0 A	112	-	17.7
	1.0	1414.11	36509	1.28	110000	PL404014C - M --- 4.0 A	112	-	17.6
5.5 kW 4 - Pole	233.9	6.20	218	2.48	3129	PL01106.3 - M --- 5.5 A	132	13.0	11.6
	193.3	7.50	264	1.53	3785	PL01107.1 - M --- 5.5 A	132	12.2	10.9
	95.9	15.12	531	1.80	7633	PL012016. - M --- 5.5 A	132	9.6	8.7
	79.1	18.33	644	1.58	9253	PL012018. - M --- 5.5 A	132	9.4	8.5
	65.2	22.22	781	1.07	11217	PL012022. - M --- 5.5 A	132	9.1	8.2
	60.1	24.11	847	1.23	12170	PL012025. - M --- 5.5 A	132	9.1	8.2
	49.7	29.17	1025	1.03	14721	PL012028. - M --- 5.5 A	132	8.8	8.0
	95.9	15.12	531	3.09	7633	PL022016. - M --- 5.5 A	132	10.4	9.5
	79.1	18.33	644	2.70	9253	PL022018. - M --- 5.5 A	132	10.2	9.2
	65.2	22.22	781	1.98	11217	PL022022. - M --- 5.5 A	132	9.9	9.0
	60.1	24.11	847	2.23	12170	PL022025. - M --- 5.5 A	132	9.8	8.9
49.7	29.17	1025	1.90	14721	PL022028. - M --- 5.5 A	132	9.6	8.7	
41.0	35.36	1242	1.28	15000	PL022036. - M --- 5.5 A	132	9.4	8.5	
37.7	38.44	1351	0.83	15000	PL022040. - M --- 5.5 A	132	9.3	8.4	
70.5	20.57	723	3.71	31691	PL032020. - M --- 5.5 A	132	14.8	14.2	
64.2	22.59	794	3.65	34795	PL032022. - M --- 5.5 A	132	14.6	14.0	
53.1	27.32	960	3.19	42090	PL032025. - M --- 5.5 A	132	14.3	13.7	
44.3	32.73	1150	2.40	44500	PL032032. - M --- 5.5 A	132	14.0	13.4	
41.6	34.88	1225	1.57	44500	PL032036. - M --- 5.5 A	132	13.8	13.3	
34.4	42.19	1482	1.32	44500	PL032045. - M --- 5.5 A	132	13.5	13.0	
28.9	50.19	1764	0.83	44500	PL032050. - M --- 5.5 A	132	13.3	12.7	
26.3	55.09	1916	1.75	44500	PL033056. - M --- 5.5 A	132	10.2	9.8	
21.7	66.79	2322	1.46	44500	PL033071. - M --- 5.5 A	132	10.1	9.7	
17.9	80.96	2815	1.22	44500	PL033080. - M --- 5.5 A	132	10.0	9.7	
16.5	87.83	3054	1.13	44500	PL033090. - M --- 5.5 A	132	10.0	9.6	
15.0	96.98	3372	0.88	44500	PL0330100 - M --- 5.5 A	132	10.0	9.6	
13.6	106.48	3703	0.94	44500	PL0330112 - M --- 5.5 A	132	9.9	9.5	
11.3	128.80	4479	0.79	44500	PL0330125 - M --- 5.5 A	132	9.8	9.4	
44.3	32.73	1150	3.69	44500	PL052032. - M --- 5.5 A	132	14.7	14.1	
41.6	34.88	1225	2.42	44500	PL052036. - M --- 5.5 A	132	14.6	14.0	
34.4	42.19	1482	2.02	44500	PL052045. - M --- 5.5 A	132	14.2	13.7	
28.9	50.19	1764	1.28	44500	PL052050. - M --- 5.5 A	132	14.0	13.4	
26.3	55.09	1916	2.70	44500	PL053056. - M --- 5.5 A	132	10.7	10.3	
21.7	66.79	2322	2.25	44500	PL053071. - M --- 5.5 A	132	10.6	10.2	
17.9	80.96	2815	1.88	44500	PL053080. - M --- 5.5 A	132	10.5	10.1	
16.5	87.83	3054	1.74	44500	PL053090. - M --- 5.5 A	132	10.5	10.1	
15.0	96.98	3372	1.35	44500	PL0530100 - M --- 5.5 A	132	10.4	10.1	
13.6	106.48	3703	1.45	44500	PL0530112 - M --- 5.5 A	132	10.4	10.0	
11.3	128.80	4479	1.22	44500	PL0530125 - M --- 5.5 A	132	10.3	9.9	
10.4	140.03	4870	1.12	44500	PL0530140 - M --- 5.5 A	132	10.3	9.9	
9.4	154.29	5365	0.87	44500	PL0530160 - M --- 5.5 A	132	10.2	9.8	
8.6	169.39	5891	0.94	44500	PL0530180 - M --- 5.5 A	132	10.2	9.8	
38.5	37.64	1323	3.93	52000	PL082036. - M --- 5.5 A	132	23.5	22.0	
32.4	44.79	1574	2.83	52000	PL082045. - M --- 5.5 A	132	23.0	21.5	
23.2	62.56	2176	4.01	52000	PL083063. - M --- 5.5 A	132	15.9	14.9	
19.3	74.94	2606	3.46	52000	PL083071. - M --- 5.5 A	132	15.7	14.7	
17.6	82.28	2861	3.22	52000	PL083080. - M --- 5.5 A	132	15.7	14.7	
16.2	89.77	3122	2.56	52000	PL083090. - M --- 5.5 A	132	15.6	14.6	
14.7	98.56	3427	2.72	52000	PL0830100 - M --- 5.5 A	132	15.5	14.5	
12.2	119.22	4146	2.28	52000	PL0830112 - M --- 5.5 A	132	15.4	14.4	
11.4	127.04	4418	2.15	52000	PL0830125 - M --- 5.5 A	132	15.3	14.3	
10.2	142.81	4966	1.65	52000	PL0830140 - M --- 5.5 A	132	15.2	14.3	
9.4	153.68	5344	1.80	52000	PL0830160 - M --- 5.5 A	132	15.2	14.2	
7.9	182.84	6358	1.53	52000	PL0830180 - M --- 5.5 A	132	15.0	14.1	
6.6	219.02	7616	1.11	52000	PL0830225 - M --- 5.5 A	132	14.9	14.0	
6.0	243.29	8460	1.17	52000	PL0840250 - M --- 5.5 A	132	11.7	11.0	
4.9	294.93	10256	0.97	52000	PL0840315 - M --- 5.5 A	132	11.5	10.8	
4.5	319.96	11127	0.90	52000	PL0840360 - M --- 5.5 A	132	11.1	10.4	
17.6	82.28	2861	3.99	52000	PL123080. - M --- 5.5 A	132	16.6	15.6	
16.2	89.77	3122	3.26	52000	PL123090. - M --- 5.5 A	132	16.5	15.5	
14.7	98.56	3427	3.37	52000	PL1230100 - M --- 5.5 A	132	16.4	15.5	
12.2	119.22	4146	2.82	52000	PL1230112 - M --- 5.5 A	132	16.3	15.3	
11.4	127.04	4418	2.66	52000	PL1230125 - M --- 5.5 A	132	16.2	15.3	
10.2	142.81	4966	2.11	52000	PL1230140 - M --- 5.5 A	132	16.1	15.2	

SERIES P

PL MOTORISED RATINGS

	N2	Ratio <i>i</i>	M2 (NM)	fm	FR2 (N)	Unit Designation	Motor Frame	PT(kW) Type B	PT (kW) Type F
5.5 kW 4 - Pole	9.4	153.68	5344	2.22	52000	PL1230160 - M --- 5.5 A	132	16.1	15.1
	7.9	182.84	6358	1.89	52000	PL1230180 - M --- 5.5 A	132	15.9	15.0
	6.6	219.02	7616	1.41	52000	PL1230225 - M --- 5.5 A	132	15.8	14.9
	6.1	237.30	8252	0.94	52000	PL1230250 - M --- 5.5 A	132	15.7	14.8
	5.1	282.33	9818	0.80	52000	PL1230280 - M --- 5.5 A	132	15.6	14.7
	6.0	243.29	8460	1.44	52000	PL1240250 - M --- 5.5 A	132	12.3	11.6
	4.9	294.93	10256	1.21	52000	PL1240315 - M --- 5.5 A	132	12.1	11.4
	4.5	319.96	11127	1.12	52000	PL1240360 - M --- 5.5 A	132	11.8	11.1
	3.7	387.05	13460	0.94	52000	PL1240400 - M --- 5.5 A	132	11.5	10.8
	13.3	109.16	3796	3.51	54000	PL1630112 - M --- 5.5 A	132	28.5	19.6
	11.4	126.82	4410	3.90	54000	PL1630125 - M --- 5.5 A	132	28.3	19.5
	10.7	135.14	4700	3.68	54000	PL1630140 - M --- 5.5 A	132	28.2	19.4
	8.9	163.48	5685	3.08	54000	PL1630160 - M --- 5.5 A	132	27.9	19.2
	7.5	194.50	6764	2.61	54000	PL1630200 - M --- 5.5 A	132	27.7	19.1
	7.1	203.91	7091	1.95	54000	PL1630225 - M --- 5.5 A	132	27.6	19.0
	6.0	242.60	8436	1.66	54000	PL1630250 - M --- 5.5 A	132	27.4	18.9
	5.1	284.77	9903	0.88	54000	PL1630280 - M --- 5.5 A	132	27.1	18.7
	6.8	213.48	7424	2.40	54000	PL1640225 - M --- 5.5 A	132	21.4	14.9
	5.6	258.79	9000	2.00	54000	PL1640280 - M --- 5.5 A	132	21.4	14.9
	4.6	313.72	10910	1.67	54000	PL1640315 - M --- 5.5 A	132	19.7	13.7
	4.3	340.35	11836	1.55	54000	PL1640360 - M --- 5.5 A	132	19.4	13.5
	3.5	411.72	14318	1.29	54000	PL1640400 - M --- 5.5 A	132	19.4	13.5
	2.9	499.10	17356	1.08	54000	PL1640500 - M --- 5.5 A	132	19.3	13.5
	2.7	542.62	18870	1.00	54000	PL1640560 - M --- 5.5 A	132	19.3	13.4
	2.4	597.86	20791	0.91	54000	PL1640630 - M --- 5.5 A	132	19.2	13.4
	2.2	656.40	22826	0.84	54000	PL1640710 - M --- 5.5 A	132	19.2	13.4
	8.8	164.53	5722	3.26	80000	PL2530160 - M --- 5.5 A	132	-	20.8
	8.1	179.15	6230	3.99	80000	PL2530180 - M --- 5.5 A	132	-	20.8
	7.4	195.75	6807	2.77	80000	PL2530200 - M --- 5.5 A	132	-	20.7
	6.2	232.89	8099	2.36	80000	PL2530250 - M --- 5.5 A	132	-	20.5
	5.2	279.92	9734	1.50	80000	PL2530280 - M --- 5.5 A	132	-	20.3
	7.0	206.43	7104	3.53	80000	PL2540200 - M --- 5.5 A	132	-	15.8
	5.8	250.24	8612	2.94	80000	PL2540250 - M --- 5.5 A	132	-	15.6
	4.8	299.76	10315	2.49	80000	PL2540280 - M --- 5.5 A	132	-	14.6
	4.4	329.11	11326	2.28	80000	PL2540315 - M --- 5.5 A	132	-	14.2
	4.0	359.06	12356	2.10	80000	PL2540360 - M --- 5.5 A	132	-	14.2
	3.6	398.11	13700	1.91	80000	PL2540400 - M --- 5.5 A	132	-	14.2
	3.0	476.88	16411	1.61	80000	PL2540450 - M --- 5.5 A	132	-	14.1
	2.9	508.18	17488	1.52	80000	PL2540500 - M --- 5.5 A	132	-	14.1
	2.4	614.73	21155	1.27	80000	PL2540630 - M --- 5.5 A	132	-	14.0
	2.0	731.37	25169	1.08	80000	PL2540710 - M --- 5.5 A	132	-	13.9
	1.8	784.69	27003	1.01	80000	PL2540800 - M --- 5.5 A	132	-	13.9
	1.7	876.08	30149	0.91	80000	PL2540900 - M --- 5.5 A	132	-	13.8
	1.5	949.22	32665	0.84	80000	PL254010C - M --- 5.5 A	132	-	13.8
	6.1	239.15	8490	3.64	110000	PL4030250 - M --- 5.5 A	132	-	26.2
5.2	280.72	9965	2.63	110000	PL4030280 - M --- 5.5 A	132	-	26.0	
5.2	277.76	9860	4.27	110000	PL4040280 - M --- 5.5 A	132	-	19.3	
4.4	332.72	11811	3.60	110000	PL4040315 - M --- 5.5 A	132	-	18.4	
4.0	365.30	12968	3.30	110000	PL4040360 - M --- 5.5 A	132	-	18.3	
3.3	441.89	15687	2.76	110000	PL4040400 - M --- 5.5 A	132	-	18.2	
3.2	455.64	16175	2.69	110000	PL4040450 - M --- 5.5 A	132	-	18.2	
2.7	529.33	18791	2.33	110000	PL4040500 - M --- 5.5 A	132	-	18.1	
2.6	564.07	20024	2.20	110000	PL4040560 - M --- 5.5 A	132	-	18.1	
2.1	682.34	24223	1.84	110000	PL4040630 - M --- 5.5 A	132	-	18.0	
2.0	715.45	25398	1.30	110000	PL4040710 - M --- 5.5 A	132	-	18.0	
1.7	851.09	30213	1.50	110000	PL4040800 - M --- 5.5 A	132	-	17.9	
1.7	865.46	30724	1.09	110000	PL4040900 - M --- 5.5 A	132	-	17.9	
1.4	1012.58	35946	1.27	110000	PL404010C - M --- 5.5 A	132	-	17.8	
1.2	1188.59	42194	1.09	110000	PL404012C - M --- 5.5 A	132	-	17.7	
1.0	1414.11	50201	0.93	110000	PL404014C - M --- 5.5 A	132	-	17.6	
2.3	628	22311	3.52	240000	PL6540630 - M --- 5.5 A	132	-	25.4	
2.1	687	24379	3.24	240000	PL6540710 - M --- 5.5 A	132	-	25.4	
1.8	817	29005	2.75	240000	PL6540800 - M --- 5.5 A	132	-	25.2	
1.5	972	34508	2.34	240000	PL654010C - M --- 5.5 A	132	-	25.1	
1.2	1168	41476	1.97	240000	PL654012C - M --- 5.5 A	132	-	25.0	
1.1	1355	48116	1.44	240000	PL654014C - M --- 5.5 A	132	-	24.9	
0.9	1642	58297	0.94	240000	PL654016C - M --- 5.5 A	132	-	24.8	
7.5 kW 4 - Pole	372.9	3.89	188	3.39	1963	PL01103.6 - M --- 7.5 A	132	15.5	13.8
	307.6	4.71	228	2.89	2379	PL01104.5 - M --- 7.5 A	132	14.3	12.8
	233.9	6.20	300	1.80	3129	PL01106.3 - M --- 7.5 A	132	13.0	11.6
	193.3	7.50	363	1.11	3785	PL01107.1 - M --- 7.5 A	132	12.2	10.9
	95.9	15.12	725	1.32	7633	PL012016 - M --- 7.5 A	132	9.6	8.7
	79.1	18.33	878	1.16	9253	PL012018 - M --- 7.5 A	132	9.4	8.5
	65.2	22.22	1065	0.79	11217	PL012022 - M --- 7.5 A	132	9.1	8.2
	60.1	24.11	1155	0.90	12170	PL012025 - M --- 7.5 A	132	9.1	8.2

PL MOTORISED RATINGS

	N2	Ratio <i>i</i>	M2 (NM)	fm	FR2 (N)	Unit Designation	Motor Frame	PT(kW) Type B	PT (kW) Type F
7.5 kW 4 - Pole	372.9	3.89	188	5.80	1963	PL02103.6 - M --- 7.5 A	132	16.0	14.4
	307.6	4.71	228	4.95	2379	PL02104.5 - M --- 7.5 A	132	14.8	13.3
	233.9	6.20	300	3.33	3129	PL02106.3 - M --- 7.5 A	132	13.5	12.1
	193.3	7.50	363	2.05	3785	PL02107.1 - M --- 7.5 A	132	12.6	11.3
	95.9	15.12	725	2.27	7633	PL022016. - M --- 7.5 A	132	10.4	9.5
	79.1	18.33	878	1.98	9253	PL022018. - M --- 7.5 A	132	10.2	9.2
	65.2	22.22	1065	1.45	11217	PL022022. - M --- 7.5 A	132	9.9	9.0
	60.1	24.11	1155	1.64	12170	PL022025. - M --- 7.5 A	132	9.8	8.9
	49.7	29.17	1398	1.39	14721	PL0222028. - M --- 7.5 A	132	9.6	8.7
	41.0	35.36	1694	0.94	15000	PL022036. - M --- 7.5 A	132	9.4	8.5
102.4	14.17	679	3.71	21825	PL032014. - M --- 7.5 A	132	15.6	14.9	
84.4	17.17	823	3.24	26457	PL032016. - M --- 7.5 A	132	15.2	14.5	
70.5	20.57	986	2.72	31691	PL032020. - M --- 7.5 A	132	14.8	14.2	
64.2	22.59	1082	2.68	34795	PL032022. - M --- 7.5 A	132	14.6	14.0	
53.1	27.32	1309	2.34	42090	PL032025. - M --- 7.5 A	132	14.3	13.7	
44.3	32.73	1568	1.76	44500	PL032032. - M --- 7.5 A	132	14.0	13.4	
41.6	34.88	1671	1.15	44500	PL032036. - M --- 7.5 A	132	13.8	13.3	
34.4	42.19	2021	0.96	44500	PL032045. - M --- 7.5 A	132	13.5	13.0	
70.5	20.57	986	3.94	31691	PL052020. - M --- 7.5 A	132	15.6	15.0	
64.2	22.59	1082	3.85	34795	PL052022. - M --- 7.5 A	132	15.4	14.8	
53.1	27.32	1309	3.37	42090	PL052025. - M --- 7.5 A	132	15.0	14.4	
44.3	32.73	1568	2.71	44500	PL052032. - M --- 7.5 A	132	14.7	14.1	
41.6	34.88	1671	1.77	44500	PL052036. - M --- 7.5 A	132	14.6	14.0	
34.4	42.19	2021	1.48	44500	PL052045. - M --- 7.5 A	132	14.2	13.7	
28.9	50.19	2405	0.94	44500	PL052050. - M --- 7.5 A	132	14.0	13.4	
26.3	55.09	2613	1.98	44500	PL053056. - M --- 7.5 A	132	10.7	10.3	
21.7	66.79	3167	1.65	44500	PL053071. - M --- 7.5 A	132	10.6	10.2	
17.9	80.96	3839	1.38	44500	PL053080. - M --- 7.5 A	132	10.5	10.1	
16.5	87.83	4165	1.28	44500	PL053090. - M --- 7.5 A	132	10.5	10.1	
15.0	96.98	4599	0.99	44500	PL0530100 - M --- 7.5 A	132	10.4	10.1	
13.6	106.48	5049	1.07	44500	PL0530112 - M --- 7.5 A	132	10.4	10.0	
11.3	128.80	6108	0.89	44500	PL0530125 - M --- 7.5 A	132	10.3	9.9	
10.4	140.03	6640	0.82	44500	PL0530140 - M --- 7.5 A	132	10.3	9.9	
45.8	31.64	1516	3.39	52000	PL082032. - M --- 7.5 A	132	24.0	22.5	
38.5	37.64	1804	2.88	52000	PL082036. - M --- 7.5 A	132	23.5	22.0	
32.4	44.79	2146	2.07	52000	PL082045. - M --- 7.5 A	132	23.0	21.5	
28.1	51.61	2447	3.36	52000	PL083056. - M --- 7.5 A	132	16.0	15.0	
23.2	62.56	2967	2.94	52000	PL083063. - M --- 7.5 A	132	15.9	14.9	
19.3	74.94	3554	2.53	52000	PL083071. - M --- 7.5 A	132	15.7	14.7	
17.6	82.28	3902	2.36	52000	PL083080. - M --- 7.5 A	132	15.7	14.7	
16.2	89.77	4257	1.88	52000	PL083090. - M --- 7.5 A	132	15.6	14.6	
14.7	98.56	4674	2.00	52000	PL0830100 - M --- 7.5 A	132	15.5	14.5	
12.2	119.22	5654	1.67	52000	PL0830112 - M --- 7.5 A	132	15.4	14.4	
11.4	127.04	6025	1.57	52000	PL0830125 - M --- 7.5 A	132	15.3	14.3	
10.2	142.81	6772	1.21	52000	PL0830140 - M --- 7.5 A	132	15.2	14.3	
9.4	153.68	7288	1.32	52000	PL0830160 - M --- 7.5 A	132	15.2	14.2	
7.9	182.84	8671	1.12	52000	PL0830180 - M --- 7.5 A	132	15.0	14.1	
6.6	219.02	10386	0.81	52000	PL0830225 - M --- 7.5 A	132	14.9	14.0	
6.0	243.29	11537	0.86	52000	PL0840250 - M --- 7.5 A	132	11.7	11.0	
32.4	44.79	2146	2.76	52000	PL122045. - M --- 7.5 A	132	24.1	22.6	
28.1	51.61	2447	4.16	52000	PL123056. - M --- 7.5 A	132	17.0	16.0	
23.2	62.56	2967	3.64	52000	PL123063. - M --- 7.5 A	132	16.8	15.8	
19.3	74.94	3554	3.19	52000	PL123071. - M --- 7.5 A	132	16.7	15.7	
17.6	82.28	3902	2.93	52000	PL123080. - M --- 7.5 A	132	16.6	15.6	
16.2	89.77	4257	2.39	52000	PL123090. - M --- 7.5 A	132	16.5	15.5	
14.7	98.56	4674	2.47	52000	PL1230100 - M --- 7.5 A	132	16.4	15.5	
12.2	119.22	5654	2.07	52000	PL1230112 - M --- 7.5 A	132	16.3	15.3	
11.4	127.04	6025	1.95	52000	PL1230125 - M --- 7.5 A	132	16.2	15.3	
10.2	142.81	6772	1.55	52000	PL1230140 - M --- 7.5 A	132	16.1	15.2	
9.4	153.68	7288	1.63	52000	PL1230160 - M --- 7.5 A	132	16.1	15.1	
7.9	182.84	8671	1.38	52000	PL1230180 - M --- 7.5 A	132	15.9	15.0	
6.6	219.02	10386	1.04	52000	PL1230225 - M --- 7.5 A	132	15.8	14.9	
6.0	243.29	11537	1.06	52000	PL1240250 - M --- 7.5 A	132	12.3	11.6	
4.9	294.93	13986	0.88	52000	PL1240315 - M --- 7.5 A	132	12.1	11.4	
4.5	319.96	15173	0.82	52000	PL1240360 - M --- 7.5 A	132	11.8	11.1	
16.6	87.52	4150	4.05	54000	PL163090. - M --- 7.5 A	132	28.8	19.9	
13.7	105.87	5020	3.39	54000	PL1630100 - M --- 7.5 A	132	28.5	19.7	
13.3	109.16	5177	2.57	54000	PL1630112 - M --- 7.5 A	132	28.5	19.6	
11.4	126.82	6014	2.86	54000	PL1630125 - M --- 7.5 A	132	28.3	19.5	
10.7	135.14	6408	2.70	54000	PL1630140 - M --- 7.5 A	132	28.2	19.4	
8.9	163.48	7752	2.26	54000	PL1630160 - M --- 7.5 A	132	27.9	19.2	
7.5	194.50	9223	1.92	54000	PL1630200 - M --- 7.5 A	132	27.7	19.1	
7.1	203.91	9669	1.43	54000	PL1630225 - M --- 7.5 A	132	27.6	19.0	
6.0	242.60	11504	1.22	54000	PL1630250 - M --- 7.5 A	132	27.4	18.9	

SERIES P

PL MOTORISED RATINGS

	N2	Ratio <i>i</i>	M2 (NM)	fm	FR2 (N)	Unit Designation	Motor Frame	PT(kW) Type B	PT (kW) Type F
7.5 kW 4 - Pole	6.8	213.48	10124	1.76	54000	PL1640225 -M--- 7.5 A	132	21.4	14.9
	5.6	258.79	12272	1.47	54000	PL1640280 -M--- 7.5 A	132	21.4	14.9
	4.6	313.72	14877	1.22	54000	PL1640315 -M--- 7.5 A	132	19.7	13.7
	4.3	340.35	16140	1.13	54000	PL1640360 -M--- 7.5 A	132	19.4	13.5
	3.5	411.72	19524	0.95	54000	PL1640400 -M--- 7.5 A	132	19.4	13.5
	11.5	126.56	6002	4.05	80000	PL2530125 -M--- 7.5 A	132	-	21.1
	9.6	150.58	7140	3.44	80000	PL2530140 -M--- 7.5 A	132	-	20.9
	8.8	164.53	7802	2.39	80000	PL2530160 -M--- 7.5 A	132	-	20.8
	8.1	179.15	8495	2.92	80000	PL2530180 -M--- 7.5 A	132	-	20.8
	7.4	195.75	9283	2.03	80000	PL2530200 -M--- 7.5 A	132	-	20.7
	6.2	232.89	11044	1.73	80000	PL2530250 -M--- 7.5 A	132	-	20.5
	5.2	279.92	13274	1.10	80000	PL2530280 -M--- 7.5 A	132	-	20.3
	7.0	206.43	9687	2.59	80000	PL2540200 -M--- 7.5 A	132	-	15.8
	5.8	250.24	11743	2.16	80000	PL2540250 -M--- 7.5 A	132	-	15.6
	4.8	299.76	14067	1.82	80000	PL2540280 -M--- 7.5 A	132	-	14.6
	4.4	329.11	15444	1.67	80000	PL2540315 -M--- 7.5 A	132	-	14.2
	4.0	359.06	16850	1.54	80000	PL2540360 -M--- 7.5 A	132	-	14.2
	3.6	398.11	18682	1.40	80000	PL2540400 -M--- 7.5 A	132	-	14.2
	3.0	476.88	22379	1.18	80000	PL2540450 -M--- 7.5 A	132	-	14.1
	2.9	508.18	23847	1.11	80000	PL2540500 -M--- 7.5 A	132	-	14.1
	2.4	614.73	28847	0.93	80000	PL2540630 -M--- 7.5 A	132	-	14.0
	2.0	731.37	34321	0.79	80000	PL2540710 -M--- 7.5 A	132	-	13.9
	7.2	201.01	9731	3.14	110000	PL4030200 -M--- 7.5 A	132	-	26.4
	6.1	239.15	11577	2.67	110000	PL4030250 -M--- 7.5 A	132	-	26.2
	5.2	280.72	13589	1.93	110000	PL4030280 -M--- 7.5 A	132	-	26.0
	6.3	229.13	11092	3.75	110000	PL4040225 -M--- 7.5 A	132	-	20.3
	5.2	277.76	13446	3.13	110000	PL4040280 -M--- 7.5 A	132	-	19.3
	4.4	332.72	16107	2.64	110000	PL4040315 -M--- 7.5 A	132	-	18.4
	4.0	365.30	17684	2.42	110000	PL4040360 -M--- 7.5 A	132	-	18.3
	3.3	441.89	21391	2.03	110000	PL4040400 -M--- 7.5 A	132	-	18.2
	3.2	455.64	22057	1.97	110000	PL4040450 -M--- 7.5 A	132	-	18.2
	2.7	529.33	25624	1.71	110000	PL4040500 -M--- 7.5 A	132	-	18.1
	2.6	564.07	27306	1.61	110000	PL4040560 -M--- 7.5 A	132	-	18.1
	2.1	682.34	33031	1.35	110000	PL4040630 -M--- 7.5 A	132	-	18.0
	2.0	715.45	34634	0.96	110000	PL4040710 -M--- 7.5 A	132	-	18.0
	1.7	851.09	41200	1.10	110000	PL4040800 -M--- 7.5 A	132	-	17.9
	1.7	865.46	41896	0.80	110000	PL4040900 -M--- 7.5 A	132	-	17.9
	1.4	1012.58	49017	0.93	110000	PL404010C -M--- 7.5 A	132	-	17.8
	1.2	1188.59	57538	0.80	110000	PL404012C -M--- 7.5 A	132	-	17.7
	3.6	407	19703.5	3.88	240000	PL6540400 -M--- 7.5 A	132	-	25.7
	3.3	445	21529.5	3.57	240000	PL6540450 -M--- 7.5 A	132	-	25.7
	3.0	488	23602.1	3.28	240000	PL6540500 -M--- 7.5 A	132	-	25.6
	2.7	528	25572.4	3.04	240000	PL6540560 -M--- 7.5 A	132	-	25.6
	2.3	628	30424.6	2.58	240000	PL6540630 -M--- 7.5 A	132	-	25.4
	2.1	687	33244.1	2.38	240000	PL6540710 -M--- 7.5 A	132	-	25.4
	1.8	817	39551.9	2.02	240000	PL6540800 -M--- 7.5 A	132	-	25.2
	1.5	972	47056.7	1.72	240000	PL654010C -M--- 7.5 A	132	-	25.1
1.2	1168	56558.5	1.44	240000	PL654012C -M--- 7.5 A	132	-	25.0	
1.1	1355	65612.8	1.06	240000	PL654014C -M--- 7.5 A	132	-	24.9	
11.0 kW 4 - Pole	398.0	3.64	259	6.48	5612	PL03103.6 -M--- 11. A	160	27.3	26.1
	332.3	4.36	310	5.61	6722	PL03104.5 -M--- 11. A	160	25.4	24.3
	257.8	5.63	399	4.30	8666	PL03105.6 -M--- 11. A	160	23.1	22.1
	216.7	6.69	475	2.72	10310	PL03107.1 -M--- 11. A	160	21.8	20.9
	398.0	3.64	259	9.32	5612	PL05103.6 -M--- 11. A	160	28.1	27.0
	332.3	4.36	310	7.87	6722	PL05104.5 -M--- 11. A	160	26.2	25.1
	257.8	5.63	399	6.35	8666	PL05105.6 -M--- 11. A	160	23.8	22.9
	216.7	6.69	475	4.18	10310	PL05107.1 -M--- 11. A	160	22.4	21.5
	59.5	24.38	1713	3.84	43873	PL082025. -M--- 11. A	160	24.9	23.3
	49.7	29.20	2052	3.31	52000	PL082028. -M--- 11. A	160	24.3	22.8
	45.8	31.64	2224	2.31	52000	PL082032. -M--- 11. A	160	24.0	22.5
	38.5	37.64	2645	1.97	52000	PL082036. -M--- 11. A	160	23.5	22.0
	32.4	44.79	3147	1.41	52000	PL082045. -M--- 11. A	160	23.0	21.5
	45.8	31.64	2224	3.09	52000	PL122032. -M--- 11. A	160	25.2	23.6
	38.5	37.64	2645	2.62	52000	PL122036. -M--- 11. A	160	24.6	23.1
	32.4	44.79	3147	1.88	52000	PL122045. -M--- 11. A	160	24.1	22.6
	38.2	37.97	2668	2.9	54000	PL162036. -M--- 11. A	160	44	30
	32.1	45.17	3175	2.5	54000	PL162045. -M--- 11. A	160	43	29
	14.9	97.52	6782	3.52	80000	PL253090. -M--- 11. A	160	-	21.4
	13.6	106.55	7411	2.45	80000	PL2530100 -M--- 11. A	160	-	21.3
	12.4	116.81	8124	2.98	80000	PL2530112 -M--- 11. A	160	-	21.2
	11.5	126.56	8802	2.76	80000	PL2530125 -M--- 11. A	160	-	21.1
	9.6	150.58	10473	2.35	80000	PL2530140 -M--- 11. A	160	-	20.9
	8.8	164.53	11443	1.63	80000	PL2530160 -M--- 11. A	160	-	20.8
	8.1	179.15	12460	1.99	80000	PL2530180 -M--- 11. A	160	-	20.8
	7.4	195.75	13614	1.39	80000	PL2530200 -M--- 11. A	160	-	20.7
	6.2	232.89	16198	1.18	80000	PL2530250 -M--- 11. A	160	-	20.5

PL MOTORISED RATINGS

	N2	Ratio <i>i</i>	M2 (NM)	fm	FR2 (N)	Unit Designation	Motor Frame	PT(kW) Type B	PT (kW) Type F	
11.0 kW 4 - Pole	10.1	143.93	10219	2.93	110000	PL4030140 - M --- 11 A	160	-	26.8	
	9.1	158.48	11252	3.61	110000	PL4030160 - M --- 11 A	160	-	26.7	
	7.7	188.55	13387	3.07	110000	PL4030180 - M --- 11 A	160	-	26.5	
	7.2	201.01	14272	2.14	110000	PL4030200 - M --- 11 A	160	-	26.4	
	6.1	239.15	16980	1.82	110000	PL4030250 - M --- 11 A	160	-	26.2	
	5.2	280.72	19931	1.32	110000	PL4030280 - M --- 11 A	160	-	26.0	
	6.6	219	15530	3.98	240000	PL6530225 - M --- 11. A	160	-	36.2	
	5.5	265	18816	2.59	240000	PL6530250 - M --- 11. A	160	-	35.9	
	6.5	222	15730	4.12	240000	PL6540225 - M --- 11. A	160	-	27.6	
	5.5	265	18843	3.64	240000	PL6540280 - M --- 11. A	160	-	26.1	
	4.6	318	22571	3.20	240000	PL6540315 - M --- 11. A	160	-	25.9	
	4.2	342	24290	3.04	240000	PL6540360 - M --- 11. A	160	-	25.9	
	3.6	407	28899	2.64	240000	PL6540400 - M --- 11. A	160	-	25.7	
	3.3	445	31577	2.43	240000	PL6540450 - M --- 11. A	160	-	25.7	
	3.0	488	34616	2.23	240000	PL6540500 - M --- 11. A	160	-	25.6	
	2.7	528	37506	2.07	240000	PL6540560 - M --- 11. A	160	-	25.6	
	2.3	628	44623	1.76	240000	PL6540630 - M --- 11. A	160	-	25.4	
	2.1	687	48758	1.62	240000	PL6540710 - M --- 11. A	160	-	25.4	
	1.8	817	58010	1.38	240000	PL6540800 - M --- 11. A	160	-	25.2	
	1.5	972	69016	1.17	240000	PL654010C - M --- 11. A	160	-	25.1	
	1.2	1168	82952	0.98	240000	PL654012C - M --- 11. A	160	-	25.0	
	15.0 kW 4 - Pole	398.0	3.64	353	4.75	5612	PL03103.6 - M --- 15. A	160	27.3	26.1
		332.3	4.36	422	4.12	6722	PL03104.5 - M --- 15. A	160	25.4	24.3
		257.8	5.63	545	3.15	8666	PL03105.6 - M --- 15. A	160	23.1	22.1
		216.7	6.69	648	1.99	10310	PL03107.1 - M --- 15. A	160	21.8	20.9
		398.0	3.64	353	6.84	5612	PL05103.6 - M --- 15. A	160	28.1	27.0
		332.3	4.36	422	5.77	6722	PL05104.5 - M --- 15. A	160	26.2	25.1
		257.8	5.63	545	4.66	8666	PL05105.6 - M --- 15. A	160	23.8	22.9
		216.7	6.69	648	3.07	10310	PL05107.1 - M --- 15. A	160	22.4	21.5
		109.3	13.27	1272	4.31	23882	PL082014. - M --- 15. A	160	27.2	25.4
		91.2	15.90	1523	3.79	28607	PL082016. - M --- 15. A	160	26.5	24.8
		76.2	19.04	1825	3.27	34267	PL082020. - M --- 15. A	160	25.8	24.1
		70.8	20.49	1964	3.18	36876	PL082022. - M --- 15. A	160	25.5	23.9
		59.5	24.38	2336	2.81	43873	PL082025. - M --- 15. A	160	24.9	23.3
		49.7	29.20	2798	2.43	52000	PL082028. - M --- 15. A	160	24.3	22.8
		45.8	31.64	3032	1.70	52000	PL082032. - M --- 15. A	160	24.0	22.5
38.5		37.64	3607	1.44	52000	PL082036. - M --- 15. A	160	23.5	22.0	
32.4		44.79	4292	1.04	52000	PL082045. - M --- 15. A	160	23.0	21.5	
76.2		19.04	1825	4.05	34267	PL122020. - M --- 15. A	160	27.0	25.4	
70.8		20.49	1964	3.93	36876	PL122022. - M --- 15. A	160	26.7	25.1	
59.5		24.38	2336	3.48	43873	PL122025. - M --- 15. A	160	26.1	24.5	
49.7		29.20	2798	3.00	52000	PL122028. - M --- 15. A	160	25.4	23.9	
45.8		31.64	3032	2.26	52000	PL122032. - M --- 15. A	160	25.2	23.6	
38.5		37.64	3607	1.92	52000	PL122036. - M --- 15. A	160	24.6	23.1	
32.4		44.79	4292	1.38	52000	PL122045. - M --- 15. A	160	24.1	22.6	
44.8		32.35	3100	3.96	54000	PL162032. - M --- 15. A	160	44.5	30.6	
38.2		37.97	3639	2.12	54000	PL162036. - M --- 15. A	160	43.5	29.9	
32.1		45.17	4329	1.80	54000	PL162045. - M --- 15. A	160	42.5	29.2	
22.8		63.6	6030	3.86	80000	PL253063. - M --- 15. A	160	-	21.9	
19.0		76.17	7224	3.26	80000	PL253071. - M --- 15. A	160	-	21.7	
17.7		81.96	7774	3.04	80000	PL253080. - M --- 15. A	160	-	21.6	
14.9		97.52	9249	2.58	80000	PL253090. - M --- 15. A	160	-	21.4	
13.6		106.55	10106	1.80	80000	PL2530100 - M --- 15. A	160	-	21.3	
12.4		116.81	11079	2.18	80000	PL2530112 - M --- 15. A	160	-	21.2	
11.5		126.56	12003	2.02	80000	PL2530125 - M --- 15. A	160	-	21.1	
9.6		150.58	14281	1.72	80000	PL2530140 - M --- 15. A	160	-	20.9	
8.8		164.53	15604	1.20	80000	PL2530160 - M --- 15. A	160	-	20.8	
8.1		179.15	16991	1.46	80000	PL2530180 - M --- 15. A	160	-	20.8	
7.4		195.75	18565	1.02	80000	PL2530200 - M --- 15. A	160	-	20.7	
6.2		232.89	22088	0.86	80000	PL2530250 - M --- 15. A	160	-	20.5	
19.4		74.73	7235	3.97	110000	PL403080. - M --- 15. A	160	-	27.8	
15.9		90.98	8808	4.45	110000	PL403090. - M --- 15. A	160	-	27.5	
13.4		108.24	10480	3.79	110000	PL4030100 - M --- 15. A	160	-	27.3	
12.8		113.48	10987	3.62	110000	PL4030112 - M --- 15. A	160	-	27.2	
10.7		135.01	13071	3.08	110000	PL4030125 - M --- 15. A	160	-	26.9	
10.1		143.93	13935	2.15	110000	PL4030140 - M --- 15. A	160	-	26.8	
9.1		158.48	15343	2.65	110000	PL4030160 - M --- 15. A	160	-	26.7	
7.7		188.55	18255	2.25	110000	PL4030180 - M --- 15. A	160	-	26.5	
7.2		201.01	19461	1.57	110000	PL4030200 - M --- 15. A	160	-	26.4	
6.1		239.15	23154	1.34	110000	PL4030250 - M --- 15. A	160	-	26.2	
5.2		280.72	27178	0.97	110000	PL4030280 - M --- 15. A	160	-	26.0	
9.9		146.7	14207	4.04	240000	PL6530160 - M --- 15. A	160	-	37.0	
7.7		188.5	18255	3.29	240000	PL6530180 - M --- 15. A	160	-	36.5	
6.6		218.7	21177	2.92	240000	PL6530225 - M --- 15. A	160	-	36.2	
5.5		265.0	25658	1.90	240000	PL6530250 - M --- 15. A	160	-	35.9	
6.5		221.6	21451	2.91	240000	PL6540225 - M --- 15. A	160	-	27.6	
5.5		265.4	25695	2.57	240000	PL6540280 - M --- 15. A	160	-	26.1	

SERIES P

PL MOTORISED RATINGS

	N2	Ratio <i>i</i>	M2 (NM)	fm	FR2 (N)	Unit Designation	Motor Frame	PT(kW) Type B	PT (κW) Type F
15.0 kW 4 - Pole	4.6	317.9	30779	2.26	240000	PL6540315 -M--- 15. A	160	-	25.9
	4.2	342.1	33122	2.15	240000	PL6540360 -M--- 15. A	160	-	25.9
	3.6	407.0	39407	1.90	240000	PL6540400 -M--- 15. A	160	-	25.7
	3.3	444.7	43059	1.78	240000	PL6540450 -M--- 15. A	160	-	25.7
	3.0	487.6	47204	1.64	240000	PL6540500 -M--- 15. A	160	-	25.6
	2.7	528.3	51145	1.52	240000	PL6540560 -M--- 15. A	160	-	25.6
	2.3	628.5	60849	1.29	240000	PL6540630 -M--- 15. A	160	-	25.4
	2.1	686.7	66488	1.19	240000	PL6540710 -M--- 15. A	160	-	25.4
	1.8	817.0	79104	1.01	240000	PL6540800 -M--- 15. A	160	-	25.2
	1.5	972.1	94113	0.86	240000	PL654010C -M--- 15. A	160	-	25.1
18.5 kW 4 - Pole	398.0	3.64	430	8.63	6556	PL08103.6 -M--- 18. A	180	40.4	37.5
	332.3	4.36	516	7.44	7853	PL08104.5 -M--- 18. A	180	37.5	34.8
	257.8	5.63	665	6.05	10123	PL08105.6 -M--- 18. A	180	34.0	31.6
	216.7	6.69	791	4.99	12044	PL08107.1 -M--- 18. A	180	32.0	29.7
	109.3	13.27	1568	3.49	23882	PL082014. -M--- 18. A	180	27.2	25.4
	91.2	15.90	1878	3.08	28607	PL082016. -M--- 18. A	180	26.5	24.8
	76.2	19.04	2250	2.65	34267	PL082020. -M--- 18. A	180	25.8	24.1
	70.8	20.49	2421	2.58	36876	PL082022. -M--- 18. A	180	25.5	23.9
	59.5	24.38	2881	2.28	43873	PL082025. -M--- 18. A	180	24.9	23.3
	49.7	29.20	3451	1.97	52000	PL082028. -M--- 18. A	180	24.3	22.8
45.8	31.64	3739	1.38	52000	PL082032. -M--- 18. A	180	24.0	22.5	
38.5	37.64	4448	1.17	52000	PL082036. -M--- 18. A	180	23.5	22.0	
32.4	44.79	5292	0.84	52000	PL082045. -M--- 18. A	180	23.0	21.5	
109.3	13.27	1568	4.32	23882	PL122014. -M--- 18. A	180	28.5	26.7	
91.2	15.90	1878	3.81	28607	PL122016. -M--- 18. A	180	27.7	26.0	
76.2	19.04	2250	3.28	34267	PL122020. -M--- 18. A	180	27.0	25.4	
70.8	20.49	2421	3.19	36876	PL122022. -M--- 18. A	180	26.7	25.1	
59.5	24.38	2881	2.82	43873	PL122025. -M--- 18. A	180	26.1	24.5	
49.7	29.20	3451	2.43	52000	PL122028. -M--- 18. A	180	25.4	23.9	
45.8	31.64	3739	1.84	52000	PL122032. -M--- 18. A	180	25.2	23.6	
38.5	37.64	4448	1.56	52000	PL122036. -M--- 18. A	180	24.6	23.1	
32.4	44.79	5292	1.12	52000	PL122045. -M--- 18. A	180	24.1	22.6	
55.9	25.93	3064	3.97	46669	PL162025. -M--- 18. A	180	45.9	31.5	
53.3	27.19	3212	3.63	48927	PL162028. -M--- 18. A	180	45.6	31.3	
44.8	32.35	3822	3.21	54000	PL162032. -M--- 18. A	180	44.5	30.6	
38.2	37.97	4486	1.72	54000	PL162036. -M--- 18. A	180	43.5	29.9	
32.1	45.17	5338	1.46	54000	PL162045. -M--- 18. A	180	42.5	29.2	
41.7	34.80	4112	4.12	80000	PL252032. -M--- 18. A	180	-	32.9	
41.2	35.16	4154	3.08	80000	PL252036. -M--- 18. A	180	-	32.9	
34.7	41.83	4942	2.62	80000	PL252040. -M--- 18. A	180	-	32.1	
27.3	53.08	6207	3.71	80000	PL253056. -M--- 18. A	180	-	22.1	
22.8	63.58	7436	3.13	80000	PL253063. -M--- 18. A	180	-	21.9	
19.0	76.17	8907	2.64	80000	PL253071. -M--- 18. A	180	-	21.7	
17.7	81.96	9585	2.47	80000	PL253080. -M--- 18. A	180	-	21.6	
14.9	97.52	11404	2.10	80000	PL253090. -M--- 18. A	180	-	21.4	
13.6	106.55	12460	1.46	80000	PL2530100 -M--- 18. A	180	-	21.3	
12.4	116.81	13660	1.77	80000	PL2530112 -M--- 18. A	180	-	21.2	
11.5	126.56	14800	1.64	80000	PL2530125 -M--- 18. A	180	-	21.1	
9.6	150.58	17608	1.39	80000	PL2530140 -M--- 18. A	180	-	20.9	
8.8	164.53	19240	0.97	80000	PL2530160 -M--- 18. A	180	-	20.8	
8.1	179.15	20949	1.19	80000	PL2530180 -M--- 18. A	180	-	20.8	
7.4	195.75	22891	0.82	80000	PL2530200 -M--- 18. A	180	-	20.7	
19.4	74.73	8923	3.22	110000	PL403080. -M--- 18. A	180	-	27.8	
15.9	90.98	10863	3.61	110000	PL403090. -M--- 18. A	180	-	27.5	
13.4	108.24	12924	3.07	110000	PL4030100 -M--- 18. A	180	-	27.3	
12.8	113.48	13549	2.94	110000	PL4030112 -M--- 18. A	180	-	27.2	
10.7	135.01	16120	2.50	110000	PL4030125 -M--- 18. A	180	-	26.9	
10.1	143.93	17186	1.74	110000	PL4030140 -M--- 18. A	180	-	26.8	
9.1	158.48	18923	2.15	110000	PL4030160 -M--- 18. A	180	-	26.7	
7.7	188.55	22513	1.82	110000	PL4030180 -M--- 18. A	180	-	26.5	
7.2	201.01	24001	1.27	110000	PL4030200 -M--- 18. A	180	-	26.4	
6.1	239.15	28555	1.08	110000	PL4030250 -M--- 18. A	180	-	26.2	
5.2	280.72	33518	0.78	110000	PL4030280 -M--- 18. A	180	-	26.0	
11.2	129.62	15477	3.86	240000	PL6530125 -M--- 18. A	180	-	37.2	
10.0	145.25	17343	4.13	240000	PL6530140 -M--- 18. A	180	-	37.0	
9.9	146.74	17521	4.09	240000	PL6530160 -M--- 18. A	180	-	37.0	
7.7	188.55	22513	3.23	240000	PL6530180 -M--- 18. A	180	-	36.5	
6.6	218.73	26117	2.37	240000	PL6530225 -M--- 18. A	180	-	36.2	
5.5	265.02	31643	1.54	240000	PL6530250 -M--- 18. A	180	-	35.9	
6.5	221.56	26454	2.78	240000	PL6540225 -M--- 18. A	180	-	27.6	
5.5	265.40	31689	2.35	240000	PL6540280 -M--- 18. A	180	-	26.1	
4.6	317.91	37959	1.98	240000	PL6540315 -M--- 18. A	180	-	25.9	
4.2	342.11	40849	1.85	240000	PL6540360 -M--- 18. A	180	-	25.9	
3.6	407.03	48599	1.57	240000	PL6540400 -M--- 18. A	180	-	25.7	
3.3	444.75	53103	1.45	240000	PL6540450 -M--- 18. A	180	-	25.7	
3.0	487.56	58215	1.33	240000	PL6540500 -M--- 18. A	180	-	25.6	
2.7	528.26	63075	1.23	240000	PL6540560 -M--- 18. A	180	-	25.6	
2.3	628.49	75043	1.05	240000	PL6540630 -M--- 18. A	180	-	25.4	
2.1	686.74	81998	0.96	240000	PL6540710 -M--- 18. A	180	-	25.4	
1.8	817.04	97556	0.82	240000	PL6540800 -M--- 18. A	180	-	25.2	

PL MOTORISED RATINGS

	N2	Ratio <i>i</i>	M2 (NM)	fm	FR2 (N)	Unit Designation	Motor Frame	PT(kW) Type B	PT (kW) Type F	
22.0 kW 4 - Pole	398.0	3.64	517	7.18	6556	PL08103.6 - M --- 22. A	180	40.4	37.5	
	332.3	4.36	620	6.19	7853	PL08104.5 - M --- 22. A	180	37.5	34.8	
	257.8	5.63	799	5.04	10123	PL08105.6 - M --- 22. A	180	34.0	31.6	
	216.7	6.69	950	4.15	12044	PL08107.1 - M --- 22. A	180	32.0	29.7	
	398.0	3.64	517	8.89	6556	PL12103.6 - M --- 22. A	180	41.6	38.8	
	332.3	4.36	620	7.66	7853	PL12104.5 - M --- 22. A	180	38.6	36.0	
	257.8	5.63	799	6.24	10123	PL12105.6 - M --- 22. A	180	35.1	32.6	
	216.7	6.69	950	5.47	12044	PL12107.1 - M --- 22. A	180	33.0	30.7	
	66.5	21.80	3064	3.76	54000	PL162022. - M --- 22. A	180	47.0	32.3	
	55.9	25.93	3645	3.33	54000	PL162025. - M --- 22. A	180	45.9	31.5	
	53.3	27.19	3821	3.05	54000	PL162028. - M --- 22. A	180	45.6	31.3	
	44.8	32.35	4546	2.70	54000	PL162032. - M --- 22. A	180	44.5	30.6	
	38.2	37.97	5336	1.45	54000	PL162036. - M --- 22. A	180	43.5	29.9	
	32.1	45.17	6349	1.23	54000	PL162045. - M --- 22. A	180	42.5	29.2	
	49.6	29.25	4111	4.07	80000	PL252028. - M --- 22. A	180	-	33.7	
	41.7	34.80	4891	3.46	80000	PL252032. - M --- 22. A	180	-	32.9	
	41.2	35.16	4941	2.59	80000	PL252036. - M --- 22. A	180	-	32.9	
	34.7	41.83	5879	2.20	80000	PL252040. - M --- 22. A	180	-	32.1	
	27.3	53.08	7384	3.11	80000	PL253056. - M --- 22. A	180	-	22.1	
	22.8	63.58	8845	2.63	80000	PL253063. - M --- 22. A	180	-	21.9	
	19.0	76.17	10595	2.22	80000	PL253071. - M --- 22. A	180	-	21.7	
	17.7	81.96	11401	2.07	80000	PL253080. - M --- 22. A	180	-	21.6	
	14.9	97.52	13565	1.76	80000	PL253090. - M --- 22. A	180	-	21.4	
	13.6	106.55	14822	1.23	80000	PL2530100 - M --- 22. A	180	-	21.3	
	12.4	116.81	16249	1.49	80000	PL2530112 - M --- 22. A	180	-	21.2	
	11.5	126.56	17605	1.38	80000	PL2530125 - M --- 22. A	180	-	21.1	
	9.6	150.58	20945	1.17	80000	PL2530140 - M --- 22. A	180	-	20.9	
	8.8	164.53	22886	0.82	80000	PL2530160 - M --- 22. A	180	-	20.8	
	20.5	70.58	10022	3.85	110000	PL403071. - M --- 22. A	180	-	27.9	
	19.4	74.73	10612	2.71	110000	PL403080. - M --- 22. A	180	-	27.8	
	15.9	90.98	12919	3.04	110000	PL403090. - M --- 22. A	180	-	27.5	
	13.4	108.24	15370	2.58	110000	PL4030100 - M --- 22. A	180	-	27.3	
	12.8	113.48	16114	2.47	110000	PL4030112 - M --- 22. A	180	-	27.2	
	10.7	135.01	19171	2.10	110000	PL4030125 - M --- 22. A	180	-	26.9	
	10.1	143.93	20438	1.47	110000	PL4030140 - M --- 22. A	180	-	26.8	
	9.1	158.48	22504	1.81	110000	PL4030160 - M --- 22. A	180	-	26.7	
	7.7	188.55	26774	1.53	110000	PL4030180 - M --- 22. A	180	-	26.5	
	7.2	201.01	28543	1.07	110000	PL4030200 - M --- 22. A	180	-	26.4	
	6.1	239.15	33959	0.91	110000	PL4030250 - M --- 22. A	180	-	26.2	
	11.9	122.09	17336	4.09	240000	PL6530112 - M --- 22. A	180	-	37.3	
	11.2	129.62	18406	3.25	240000	PL6530125 - M --- 22. A	180	-	37.2	
	10.0	145.25	20626	3.47	240000	PL6530140 - M --- 22. A	180	-	37.0	
	9.9	146.74	20837	3.44	240000	PL6530160 - M --- 22. A	180	-	37.0	
	7.7	188.55	26774	2.72	240000	PL6530180 - M --- 22. A	180	-	36.5	
	6.6	218.73	31060	1.99	240000	PL6530225 - M --- 22. A	180	-	36.2	
	5.5	265.02	37632	1.29	240000	PL6530250 - M --- 22. A	180	-	35.9	
	6.5	221.56	31461	2.34	240000	PL6540225 - M --- 22. A	180	-	27.6	
	5.5	265.40	37686	1.97	240000	PL6540280 - M --- 22. A	180	-	26.1	
	4.6	317.91	45142	1.67	240000	PL6540315 - M --- 22. A	180	-	25.9	
	4.2	342.11	48579	1.56	240000	PL6540360 - M --- 22. A	180	-	25.9	
	3.6	407.03	57797	1.32	240000	PL6540400 - M --- 22. A	180	-	25.7	
	3.3	444.75	63153	1.22	240000	PL6540450 - M --- 22. A	180	-	25.7	
	3.0	487.56	69233	1.12	240000	PL6540500 - M --- 22. A	180	-	25.6	
	2.7	528.26	75012	1.04	240000	PL6540560 - M --- 22. A	180	-	25.6	
	2.3	628.49	89245	0.88	240000	PL6540630 - M --- 22. A	180	-	25.4	
	2.1	686.74	97516	0.81	240000	PL6540710 - M --- 22. A	180	-	25.4	
	30.0 kW 4 - Pole	398.0	3.64	705	5.27	6556	PL08103.6 - M --- 30. A	200	40.4	37.5
		332.3	4.36	845	4.54	7853	PL08104.5 - M --- 30. A	200	37.5	34.8
		257.8	5.63	1089	3.69	10123	PL08105.6 - M --- 30. A	200	34.0	31.6
		216.7	6.69	1296	3.04	12044	PL08107.1 - M --- 30. A	200	32.0	29.7
		398.0	3.64	705	6.52	6556	PL12103.6 - M --- 30. A	200	41.6	38.8
		332.3	4.36	845	5.62	7853	PL12104.5 - M --- 30. A	200	38.6	36.0
		257.8	5.63	1089	4.57	10123	PL12105.6 - M --- 30. A	200	35.1	32.6
		216.7	6.69	1296	4.01	12044	PL12107.1 - M --- 30. A	200	33.0	30.7
		374.2	3.88	750	9.15	9691	PL16104.0 - M --- 30. A	200	76.9	52.3
		300.0	4.83	936	7.41	12088	PL16105.0 - M --- 30. A	200	70.4	47.8
		214.8	6.75	1307	5.29	16882	PL16107.1 - M --- 30. A	200	62.4	42.4
		362.5	4.00	775	13.73	11086	PL25104.0 - M --- 30. A	200	-	55.5
		278.8	5.20	1007	11.43	14412	PL25105.0 - M --- 30. A	200	-	50.0
		232.0	6.25	1210	9.49	17322	PL25106.3 - M --- 30. A	200	-	46.8
		99.5	14.57	2822	5.55	40384	PL252014. - M --- 30. A	200	-	37.4
		83.1	17.45	3380	4.89	48374	PL252018. - M --- 30. A	200	-	36.4
64.4		22.50	4357	4.10	62358	PL252022. - M --- 30. A	200	-	35.0	
54.2		26.77	5183	3.63	74190	PL252025. - M --- 30. A	200	-	34.2	
49.6		29.25	5664	2.96	80000	PL252028. - M --- 30. A	200	-	33.7	

SERIES P

PL MOTORISED RATINGS

	N2	Ratio <i>i</i>	M2 (NM)	fm	FR2 (N)	Unit Designation	Motor Frame	PT(kW) Type B	PT (kW) Type F	
30.0 kW 4 - Pole	41.7	34.80	6738	2.51	80000	PL252032. - M --- 30. A	200	-	32.9	
	41.2	35.16	6807	1.88	80000	PL252036. - M --- 30. A	200	-	32.9	
	34.7	41.83	8099	1.60	80000	PL252040. - M --- 30. A	200	-	32.1	
	56.7	25.59	4955	5.42	100279	PL402025. - M --- 30. A	200	-	44.6	
	51.5	28.17	5455	6.41	110000	PL402028. - M --- 30. A	200	-	43.9	
	48.3	30.04	5816	3.92	110000	PL402032. - M --- 30. A	200	-	43.5	
	40.6	35.74	6920	3.97	110000	PL402036. - M --- 30. A	200	-	42.5	
	34.6	41.95	8122	2.87	110000	PL402045. - M --- 30. A	200	-	41.5	
	17.2	84.5	16365	3.56	240000	PL653080. - M --- 30. A	200	-	38.1	
	15.4	93.9	18185	3.83	240000	PL653090. - M --- 30. A	200	-	37.9	
	13.0	111.7	21635	3.26	240000	PL6530100 - M --- 30. A	200	-	37.5	
	11.9	122.1	23640	3.00	240000	PL6530112 - M --- 30. A	200	-	37.3	
	11.2	129.6	25099	2.38	240000	PL6530125 - M --- 30. A	200	-	37.2	
	10.0	145.3	28126	2.55	240000	PL6530140 - M --- 30. A	200	-	37.0	
	9.9	146.7	28414	2.52	240000	PL6530160 - M --- 30. A	200	-	37.0	
	7.7	188.5	36509	1.99	240000	PL6530180 - M --- 30. A	200	-	36.5	
	6.6	218.7	42354	1.46	240000	PL6530225 - M --- 30. A	200	-	36.2	
	5.5	265.0	51316	0.95	240000	PL6530250 - M --- 30. A	200	-	35.9	
	37.0 kW 4 - Pole	374.2	3.88	925	7.42	9691	PL16104.0 - M --- 37. A	225	76.9	52.3
		300.0	4.83	1154	6.01	12088	PL16105.0 - M --- 37. A	225	70.4	47.8
214.8		6.75	1612	4.29	16882	PL16107.1 - M --- 37. A	225	62.4	42.4	
362.5		4.00	955	11.13	11086	PL25104.0 - M --- 37. A	225	-	55.5	
278.8		5.20	1242	9.26	14412	PL25105.0 - M --- 37. A	225	-	50.0	
232.0		6.25	1493	7.69	17322	PL25106.3 - M --- 37. A	225	-	46.8	
89.7		16.17	3863	7.66	63385	PL402016. - M --- 37. A	225	-	47.8	
71.9		20.17	4818	6.56	79060	PL402020. - M --- 37. A	225	-	46.2	
56.7		25.59	6111	4.40	100279	PL402025. - M --- 37. A	225	-	44.6	
51.5		28.17	6728	5.19	110000	PL402028. - M --- 37. A	225	-	43.9	
48.3		30.04	7173	3.18	110000	PL402032. - M --- 37. A	225	-	43.5	
40.6		35.74	8534	3.21	110000	PL402036. - M --- 37. A	225	-	42.5	
34.6		41.95	10017	2.32	110000	PL402045. - M --- 37. A	225	-	41.5	
47.9		30.26	7227	7.55	240000	PL652032. - M --- 37. A	225	-	55.9	
39.5		36.67	8757	4.91	240000	PL652040. - M --- 37. A	225	-	56.1	
45.0 kW 4 - Pole		374.2	3.88	1126	6.10	9691	PL16104.0 - M --- 45. A	225	76.9	52.3
	300.0	4.83	1404	4.94	12088	PL16105.0 - M --- 45. A	225	70.4	47.8	
	214.8	6.75	1961	3.53	16882	PL16107.1 - M --- 45. A	225	62.4	42.4	
	362.5	4.00	1162	9.2	11086	PL25104.0 - M --- 45. A	225	-	55.5	
	278.8	5.20	1510	7.4	14412	PL25105.0 - M --- 45. A	225	-	50.0	
	232.0	6.25	1815	6.3	17322	PL25106.3 - M --- 45. A	225	-	46.8	
	89.7	16.17	4698	6.30	63385	PL402016. - M --- 45. A	225	-	47.8	
	71.9	20.17	5860	5.40	79060	PL402020. - M --- 45. A	225	-	46.2	
	56.7	25.59	7432	3.61	100279	PL402025. - M --- 45. A	225	-	44.6	
	51.5	28.17	8183	4.27	110000	PL402028. - M --- 45. A	225	-	43.9	
	48.3	30.04	8724	2.61	110000	PL402032. - M --- 45. A	225	-	43.5	
	40.6	35.74	10379	2.64	110000	PL402036. - M --- 45. A	225	-	42.5	
	34.6	41.95	12183	1.91	110000	PL402045. - M --- 45. A	225	-	41.5	
	57.6	25.18	7313	7.38	209017	PL652022. - M --- 45. A	225	-	55.6	
	55.6	26.09	7577	8.48	216554	PL652028. - M --- 45. A	225	-	55.7	
	47.9	30.26	8790	6.21	240000	PL652032. - M --- 45. A	225	-	55.9	
	39.5	36.67	10650	4.04	240000	PL652040. - M --- 45. A	225	-	56.1	

RIGHT ANGLE UNITS
SERIES PR



SERIES P

PR01

Series P	Ratio <i>i</i> N	Ratio <i>i</i>	T2 (Nm) n2*h rating						n1 Max	Pt (kW)	
			10,000	25,000	50,000	100,000	500,000	1,000,000		Type B	Type F
PR0120	12.	12.26	1305	1224	1207	1110	946	769	3500	9.5	8.8
	14.	14.87	1220	1123	986	900	824	751		9.3	8.6
	18.	19.55	895	753	660	629	575	552		9.1	8.4
	22.	23.65	643	539	482	464	422	404		8.9	8.3
PR0130	45.	47.70	1305	1224	1207	1110	946	769	3500	8.0	7.5
	56.	57.82	1305	1224	1207	1110	946	769		7.9	7.4
	71.	70.09	1220	1123	986	900	824	751		7.9	7.3
	80.	76.04	1305	1224	1207	1110	946	769		7.8	7.3
	90.	91.99	1305	1224	1207	1110	946	769		7.8	7.3
	112	111.51	1220	1123	986	900	824	751		7.7	7.2
	125	121.23	895	753	660	629	575	552		7.7	7.2
	140	146.65	895	753	660	629	575	552		7.6	7.1
PR0140	160	177.40	643	539	482	464	422	404	3500	7.6	7.1
	180	185.49	1305	1224	1207	1110	946	769		7.3	6.9
	225	224.86	1305	1224	1207	1110	946	769		7.2	6.8
	250	272.58	1305	1224	1207	1110	946	769		7.2	6.8
	280	295.72	1305	1224	1207	1110	946	769		7.2	6.8
	315	330.44	1220	1123	986	900	824	751		7.2	6.7
	360	357.73	1305	1224	1207	1110	946	769		7.1	6.7
	400	433.65	1305	1224	1207	1110	946	769		7.1	6.7
	450	471.46	1305	1224	1207	1110	946	769		7.1	6.7
	500	525.69	1220	1123	986	900	824	751		7.1	6.6
	560	570.32	1305	1224	1207	1110	946	769		7.0	6.6
	710	689.90	1305	1224	1207	1110	946	769		7.0	6.6
	800	836.33	1220	1123	986	900	824	751		7.0	6.6
	900	909.25	895	753	660	629	575	552		7.0	6.5
11C	1099.9	895	753	660	629	575	552	6.9	6.5		
13C	1330.5	643	539	482	464	422	404	6.9	6.5		

SERIES P

PR01

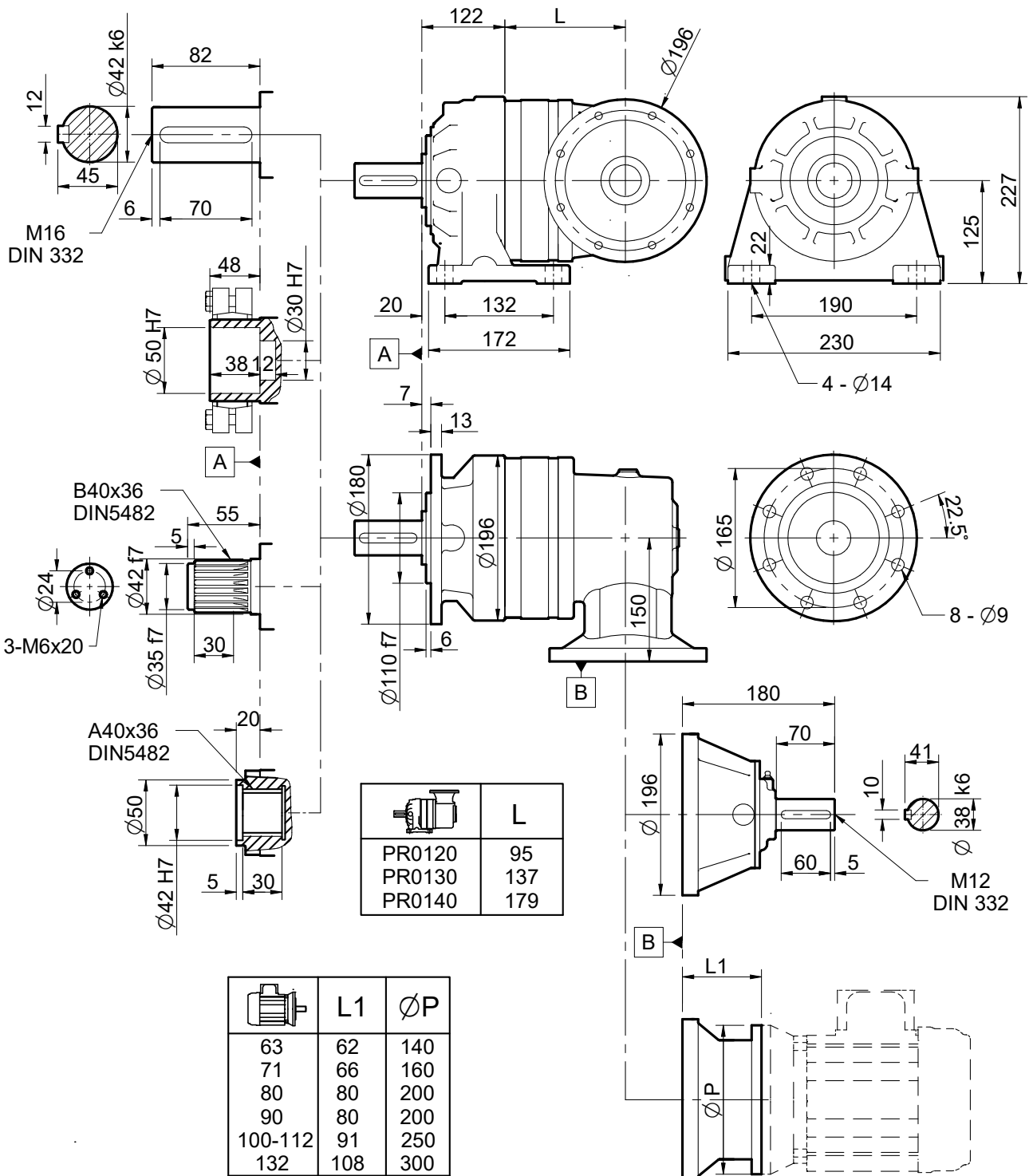

SERIES P

PR02

Series P	Ratio <i>i</i> N	Ratio <i>i</i>	T2 (Nm) n2*h rating						n1 Max	Pt (kW)	
			10,000	25,000	50,000	100,000	500,000	1,000,000		Type B	Type F
PR0220	12.	12.26	1594	1594	1594	1594	1594	1317	3500	9.7	9.0
	14.	14.87	1933	1933	1829	1661	1523	1286		9.5	8.9
	18.	19.55	1655	1391	1219	1162	1063	1020		9.3	8.6
	22.	23.65	1188	996	891	856	780	745		9.1	8.5
PR0230	45.	47.70	2398	2247	2215	2050	1622	1317	3500	8.5	7.9
	56.	57.82	2398	2247	2215	2050	1622	1317		8.4	7.9
	71.	70.09	2239	2074	1829	1661	1523	1286		8.3	7.8
	80.	76.04	2398	2247	2215	2050	1622	1317		8.3	7.8
	90.	91.99	2398	2247	2215	2050	1622	1317		8.2	7.7
	112	111.51	2239	2074	1829	1661	1523	1286		8.1	7.6
	125	121.23	1655	1391	1219	1162	1063	1020		8.1	7.6
	140	146.65	1655	1391	1219	1162	1063	1020		8.0	7.5
160	177.40	1188	996	891	856	780	745	8.0	7.5		
PR0240	180	185.49	2398	2247	2215	2050	1622	1317	3500	7.4	7.0
	225	224.86	2398	2247	2215	2050	1622	1317		7.4	7.0
	250	272.58	2398	2247	2215	2050	1622	1317		7.3	6.9
	280	295.72	2398	2247	2215	2050	1622	1317		7.3	6.9
	315	330.44	2239	2074	1829	1661	1523	1286		7.3	6.9
	360	357.73	2398	2247	2215	2050	1622	1317		7.3	6.9
	400	433.65	2398	2247	2215	2050	1622	1317		7.2	6.8
	450	471.46	2398	2247	2215	2050	1622	1317		7.2	6.8
	500	525.69	2239	2074	1829	1661	1523	1286		7.2	6.8
	560	570.32	2398	2247	2215	2050	1622	1317		7.2	6.8
	710	689.90	2398	2247	2215	2050	1622	1317		7.1	6.7
	800	836.33	2239	2074	1829	1661	1523	1286		7.1	6.7
	900	909.25	1655	1391	1219	1162	1063	1020		7.1	6.7
	11C	1099.90	1655	1391	1219	1162	1063	1020		7.1	6.6
13C	1330.53	1188	996	891	856	780	745	7.0	6.6		

SERIES P

PR02

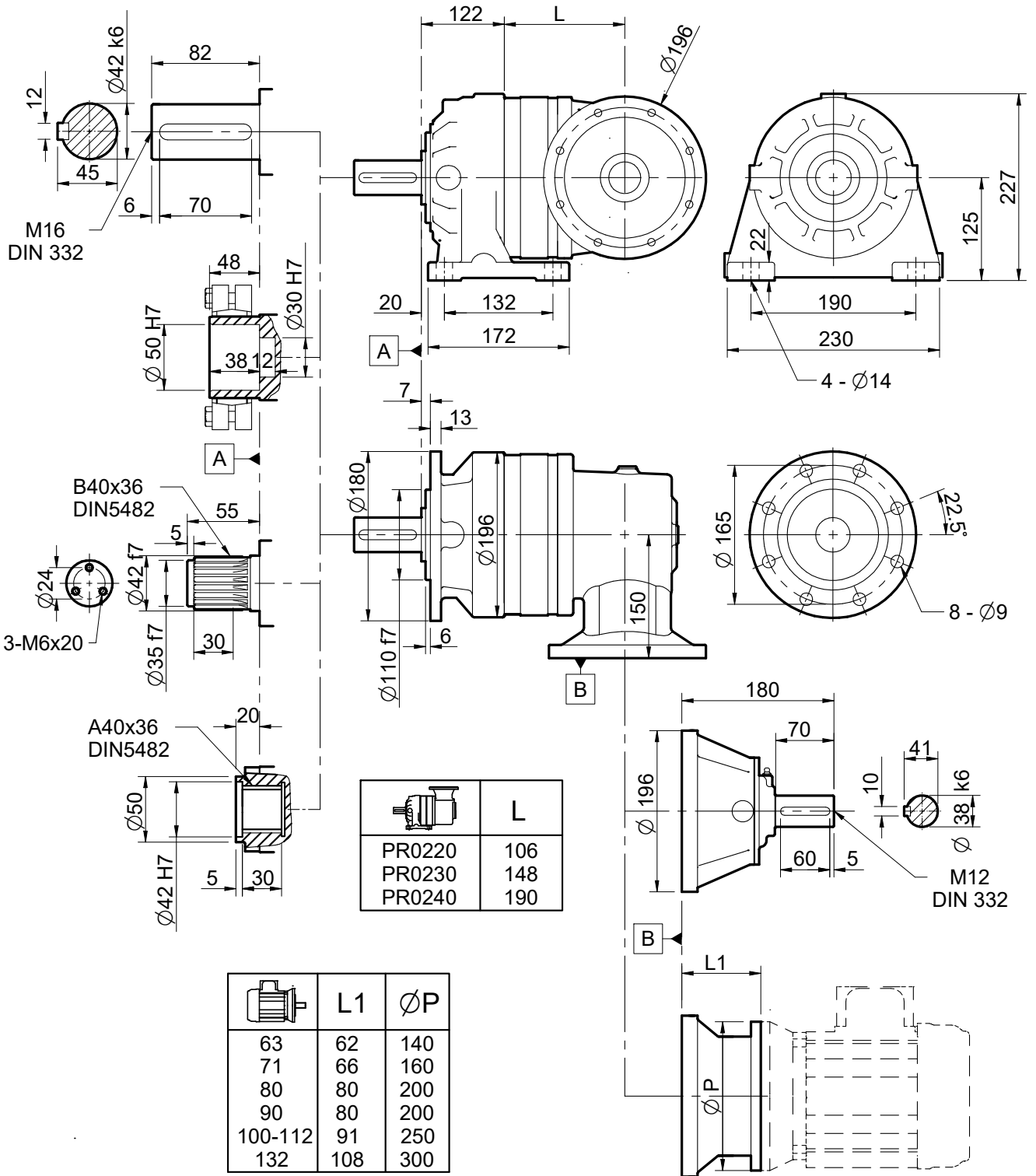

SERIES P

PR03

Series P	Ratio iN	Ratio i	T2 (Nm) n2*h rating						n1 Max	Pt (kW) Type B	Pt (kW) Type F
			10,000	25,000	50,000	100,000	500,000	1,000,000			
PR0320	14.	14.24	3930	3700	3648	3400	2536	2060	3500	15.4	14.9
	18.	17.06	3598	3350	3199	2887	2493	2025		15.1	14.7
	22.	21.99	2891	2432	2137	2008	1838	1765		14.8	14.3
	25.	26.16	2100	1764	1553	1494	1364	1306		14.5	14.1
PR0330	45.	44.68	3930	3700	3648	3400	2536	2060	3500	11.3	10.9
	56.	54.16	3930	3700	3648	3400	2536	2060		11.2	10.8
	63.	64.88	3598	3350	3199	2887	2493	2025		11.1	10.7
	71.	71.23	3930	3700	3648	3400	2536	2060		11.0	10.7
	90.	86.17	3930	3700	3648	3400	2536	2060		10.9	10.6
	100	103.22	3598	3350	3199	2887	2493	2025		10.9	10.5
	112	109.99	2891	2432	2137	2008	1838	1765		10.8	10.5
	140	133.05	2891	2432	2137	2008	1838	1765		10.7	10.4
160	158.30	2100	1764	1553	1494	1364	1306	10.7	10.3		
PR0340	180	173.75	3930	3700	3648	3400	2536	2060	3500	9.7	9.4
	200	210.63	3930	3700	3648	3400	2536	2060		9.7	9.4
	250	255.34	3930	3700	3648	3400	2536	2060		9.6	9.3
	280	277.01	3930	3700	3648	3400	2536	2060		9.6	9.3
	315	305.86	3598	3350	3199	2887	2493	2025		9.6	9.3
	360	335.10	3930	3700	3648	3400	2536	2060		9.5	9.2
	400	406.22	3930	3700	3648	3400	2536	2060		9.5	9.2
	450	441.64	3930	3700	3648	3400	2536	2060		9.5	9.2
	500	486.59	3598	3350	3199	2887	2493	2025		9.4	9.1
	560	534.24	3930	3700	3648	3400	2536	2060		9.4	9.1
	630	646.26	3930	3700	3648	3400	2536	2060		9.4	9.1
	710	774.13	3598	3350	3199	2887	2493	2025		9.3	9.0
	800	824.93	2891	2432	2137	2008	1838	1765		9.3	9.0
	10C	997.90	2891	2432	2137	2008	1838	1765		9.2	9.0
12C	1187.2	2100	1764	1553	1494	1364	1306	9.2	8.9		

SERIES P

PR03

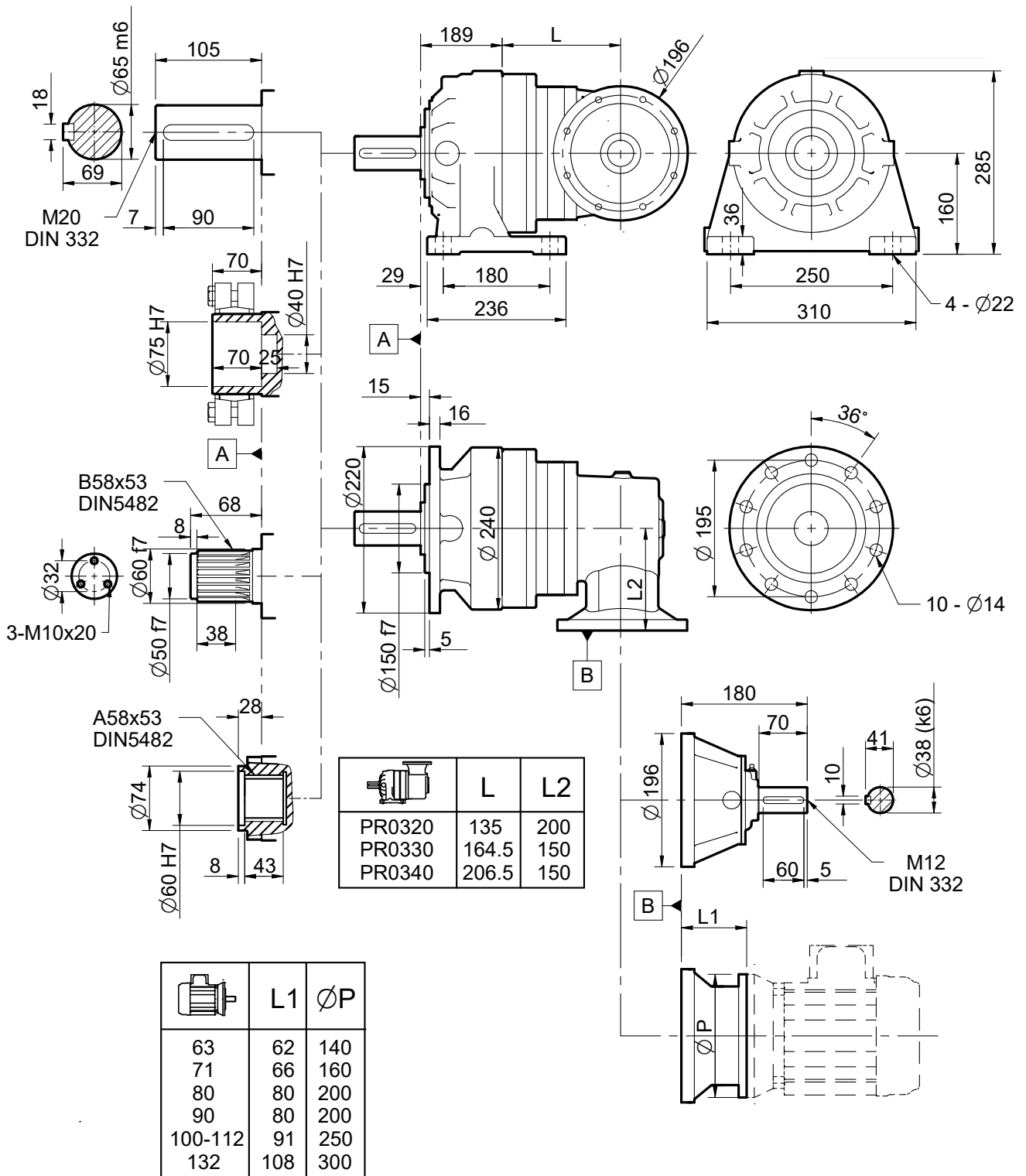

SERIES P

PR05

Series P	Ratio <i>i</i> N	Ratio <i>i</i>	T2 (Nm) n2*h rating						n1 Max	Pt (kW)	
			10,000	25,000	50,000	100,000	500,000	1,000,000		Type B	Type F
PR0520	14.	14.24	3930	3930	3930	3930	3556	2889	3500	15.8	15.3
	18.	17.06	4708	4708	4708	4442	3498	2841		15.5	15.0
	22.	21.99	4448	3742	3287	3089	2828	2716		15.1	14.7
	25.	26.16	3232	2715	2389	2298	2099	2010		14.9	14.4
PR0530	45.	44.68	5808	5675	5595	5231	3556	2889	3500	11.7	11.4
	56.	54.16	6028	5675	5595	5231	3556	2889		11.6	11.3
	63.	64.88	5519	5139	4920	4442	3498	2841		11.5	11.2
	71.	71.23	6028	5675	5595	5231	3556	2889		11.5	11.1
	90.	86.17	6028	5675	5595	5231	3556	2889		11.4	11.0
	100	103.22	5519	5139	4920	4442	3498	2841		11.3	11.0
	112	109.99	4448	3742	3287	3089	2828	2716		11.3	10.9
	140	133.05	4448	3742	3287	3089	2828	2716		11.2	10.8
160	158.30	3232	2715	2389	2298	2099	2010	11.1	10.8		
PR0540	180	173.75	6028	5675	5595	5231	3556	2889	3500	10.1	9.8
	200	210.63	6028	5675	5595	5231	3556	2889		10.0	9.7
	250	255.34	6028	5675	5595	5231	3556	2889		10.0	9.7
	280	277.01	6028	5675	5595	5231	3556	2889		10.0	9.7
	315	305.86	5519	5139	4920	4442	3498	2841		9.9	9.6
	360	335.10	6028	5675	5595	5231	3556	2889		9.9	9.6
	400	406.22	6028	5675	5595	5231	3556	2889		9.8	9.6
	450	441.64	6028	5675	5595	5231	3556	2889		9.8	9.5
	500	486.59	5519	5139	4920	4442	3498	2841		9.8	9.5
	560	534.24	6028	5675	5595	5231	3556	2889		9.8	9.5
	630	646.26	6028	5675	5595	5231	3556	2889		9.7	9.4
	710	774.13	5519	5139	4920	4442	3498	2841		9.7	9.4
	800	824.93	4448	3742	3287	3089	2828	2716		9.6	9.4
	10C	997.90	4448	3742	3287	3089	2828	2716		9.6	9.3
12C	1187.24	3232	2715	2389	2298	2099	2010	9.5	9.3		

SERIES P

PR05

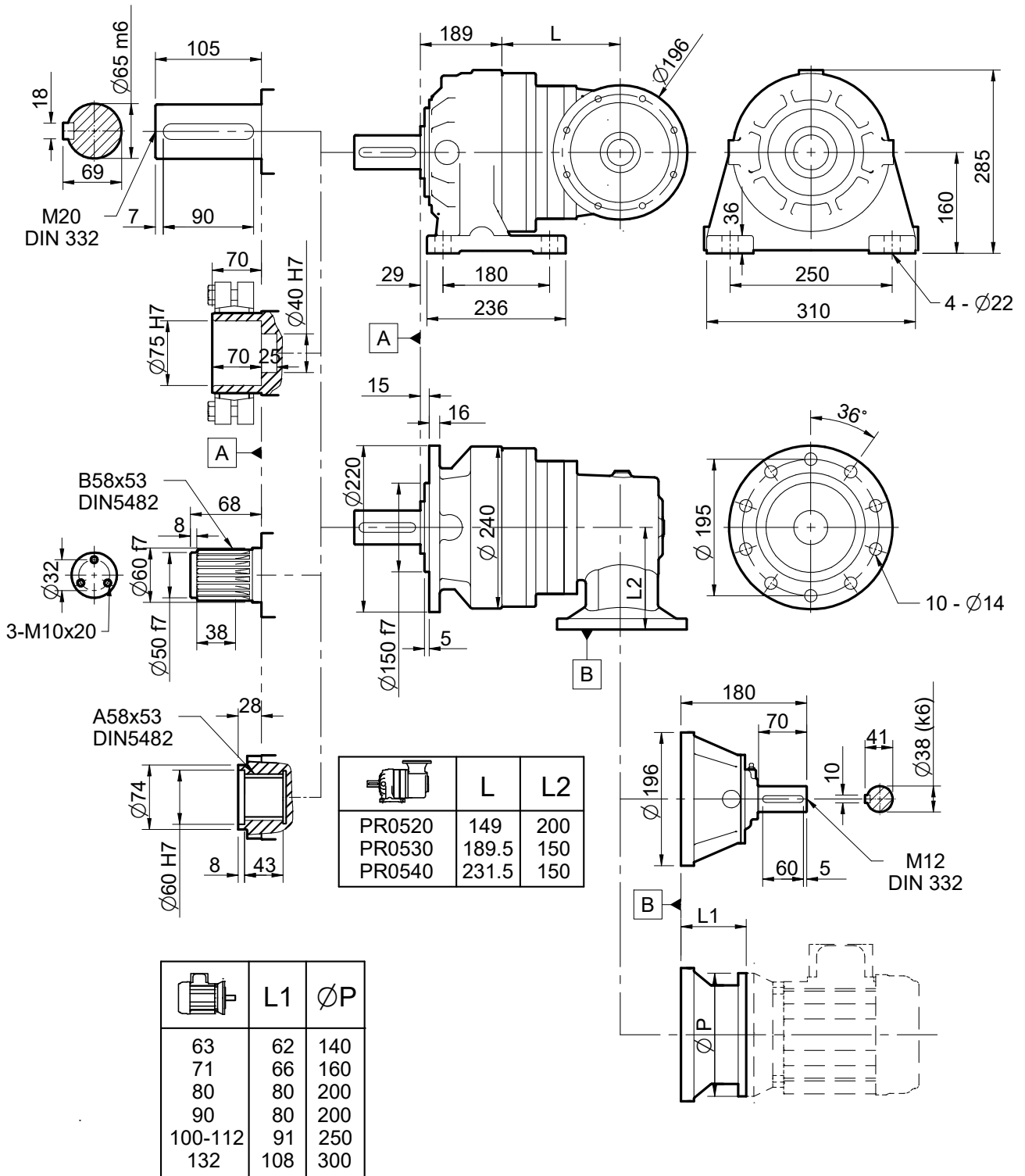

SERIES P

PR08

Series P	Ratio iN	Ratio i	T2 (Nm) n2*h rating						n1 Max	Pt (kW)	
			10,000	25,000	50,000	100,000	500,000	1,000,000		Type B	Type F
PR0820	14.	14.24	8117	8117	8117	8117	5622	4567	3500	25.9	24.6
	18.	17.06	9723	9330	8295	7840	5502	4469		25.4	24.0
	22.	21.99	7742	6521	5734	5396	4949	4341		24.7	23.4
	25.	26.16	6389	5377	4740	4564	4180	4014		24.2	22.9
PR0830	50.	51.88	10669	10034	9889	9112	5622	4567	3500	16.8	15.9
	63.	62.14	10669	10034	9889	9112	5622	4567		16.7	15.8
	71.	74.43	10055	9330	8295	7840	5502	4469		16.5	15.7
	80.	80.10	10669	10034	9889	9112	5622	4567		16.5	15.6
	100	95.30	10669	10034	9889	9112	5622	4567		16.4	15.5
	112	114.16	10055	9330	8295	7840	5502	4469		16.2	15.4
	125	123.69	7742	6521	5734	5396	4949	4341		16.2	15.3
	140	147.15	7742	6521	5734	5396	4949	4341		16.1	15.2
180	175.08	6389	5377	4740	4564	4180	4014	15.9	15.1		
PR0840	180	162.76	10669	10034	9889	9112	5622	4567	3500	13.5	12.8
	200	197.31	10669	10034	9889	9112	5622	4567		13.4	12.7
	225	236.35	10669	10034	9889	9112	5622	4567		13.3	12.6
	250	259.49	10669	10034	9889	9112	5622	4567		13.3	12.6
	280	283.11	10055	9330	8295	7840	5502	4469		13.3	12.5
	315	313.90	10669	10034	9889	9112	5622	4567		13.2	12.5
	360	376.00	10669	10034	9889	9112	5622	4567		13.1	12.4
	400	400.68	10669	10034	9889	9112	5622	4567		13.1	12.4
	450	450.40	10055	9330	8295	7840	5502	4469		13.1	12.4
	500	484.69	10669	10034	9889	9112	5622	4567		13.0	12.3
	560	576.66	10669	10034	9889	9112	5622	4567		13.0	12.3
	630	618.70	7742	6521	5734	5396	4949	4341		13.0	12.3
	710	690.76	10055	9330	8295	7840	5502	4469		12.9	12.2
	800	748.42	7742	6521	5734	5396	4949	4341		12.9	12.2
	900	890.43	7742	6521	5734	5396	4949	4341		12.8	12.1
11C	1059.4	6389	5377	4740	4564	4180	4014	12.8	12.1		

SERIES P

PR08

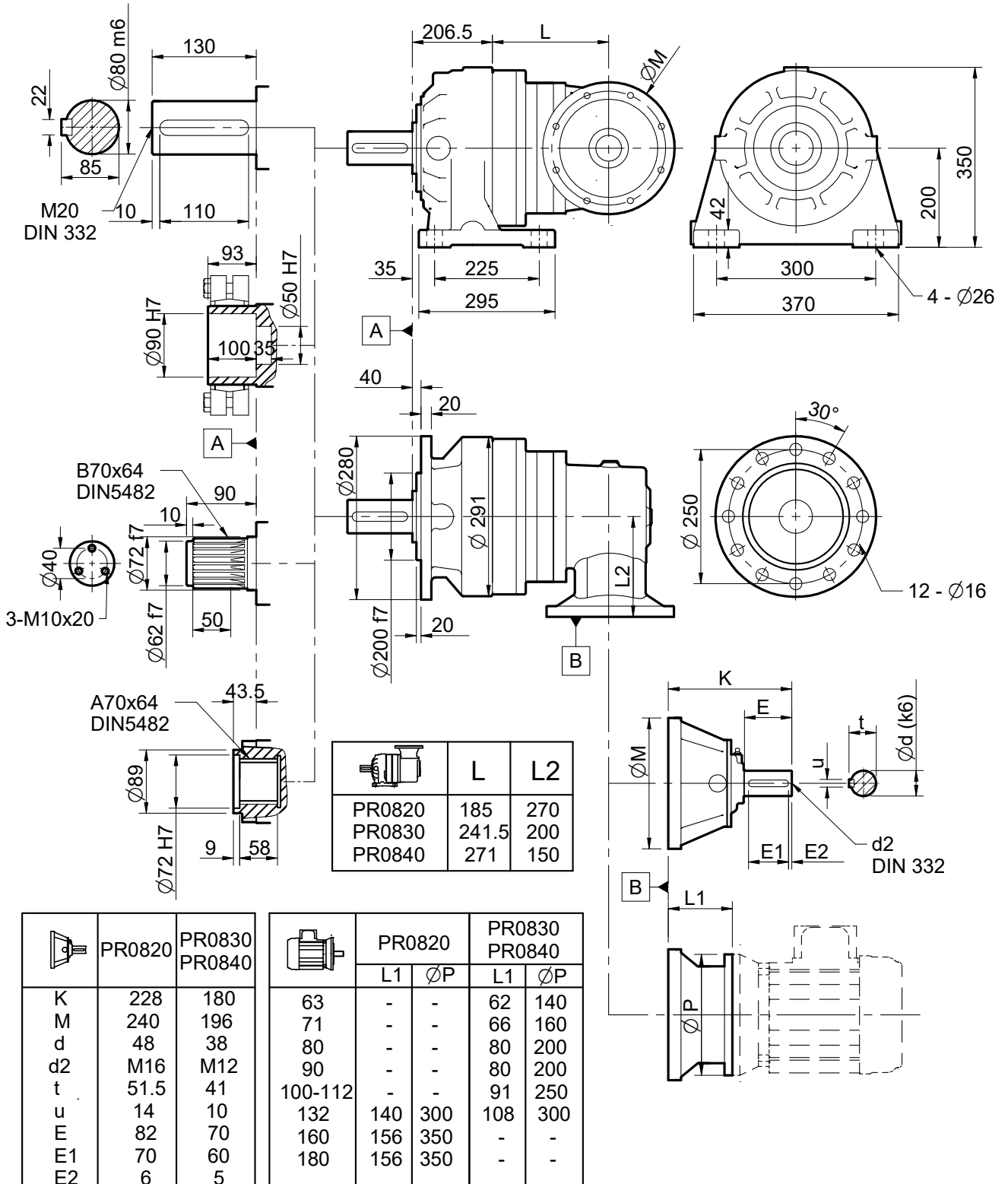

SERIES P

PR12

Series P	Ratio <i>i</i> N	Ratio <i>i</i>	T2 (Nm) n2*h rating						n1 Max	Pt (kW) Type B	Pt (kW) Type F
			10,000	25,000	50,000	100,000	500,000	1,000,000			
PR1220	14.	14.24	8117	8117	8117	8117	6958	5652	3500	26.5	25.2
	18.	17.06	9723	9723	9723	9723	6813	5534		26.0	24.6
	22.	21.99	10324	8700	7655	7196	6597	5375		25.2	23.9
	25.	26.16	8519	7170	6323	6084	5573	5325		24.7	23.5
PR1230	50.	51.88	14202	13356	13168	11277	6958	5652	3500	17.5	16.6
	63.	62.14	14202	13356	13168	11277	6958	5652		17.3	16.4
	71.	74.43	13385	12420	11064	9996	6813	5534		17.2	16.3
	80.	80.10	14202	13356	13168	11277	6958	5652		17.1	16.3
	100	95.30	14202	13356	13168	11277	6958	5652		17.0	16.1
	112	114.16	13385	12420	11064	9996	6813	5534		16.9	16.0
	125	123.69	10324	8700	7655	7196	6597	5375		16.8	16.0
	140	147.15	10324	8700	7655	7196	6597	5375		16.7	15.8
PR1240	180	175.08	8519	7170	6323	6084	5573	5325	3500	16.6	15.7
	180	162.76	14202	13356	13168	11277	6958	5652		14.2	13.4
	200	197.31	14202	13356	13168	11277	6958	5652		14.1	13.4
	225	236.35	14202	13356	13168	11277	6958	5652		14.0	13.3
	250	259.49	14202	13356	13168	11277	6958	5652		14.0	13.2
	280	283.11	13385	12420	11064	9996	6813	5534		13.9	13.2
	315	313.90	14202	13356	13168	11277	6958	5652		13.9	13.2
	360	376.00	14202	13356	13168	11277	6958	5652		13.8	13.1
	400	400.68	14202	13356	13168	11277	6958	5652		13.8	13.1
	450	450.40	13385	12420	11064	9996	6813	5534		13.7	13.0
	500	484.69	14202	13356	13168	11277	6958	5652		13.7	13.0
	560	576.66	14202	13356	13168	11277	6958	5652		13.6	12.9
	630	618.70	10324	8700	7655	7196	6597	5375		13.6	12.9
	710	690.76	13385	12420	11064	9996	6813	5534		13.6	12.9
	800	748.42	10324	8700	7655	7196	6597	5375		13.5	12.8
900	890.43	10324	8700	7655	7196	6597	5375	13.5	12.8		
11C	1059.4	8519	7170	6323	6084	5573	5325	13.4	12.7		

SERIES P

PR12

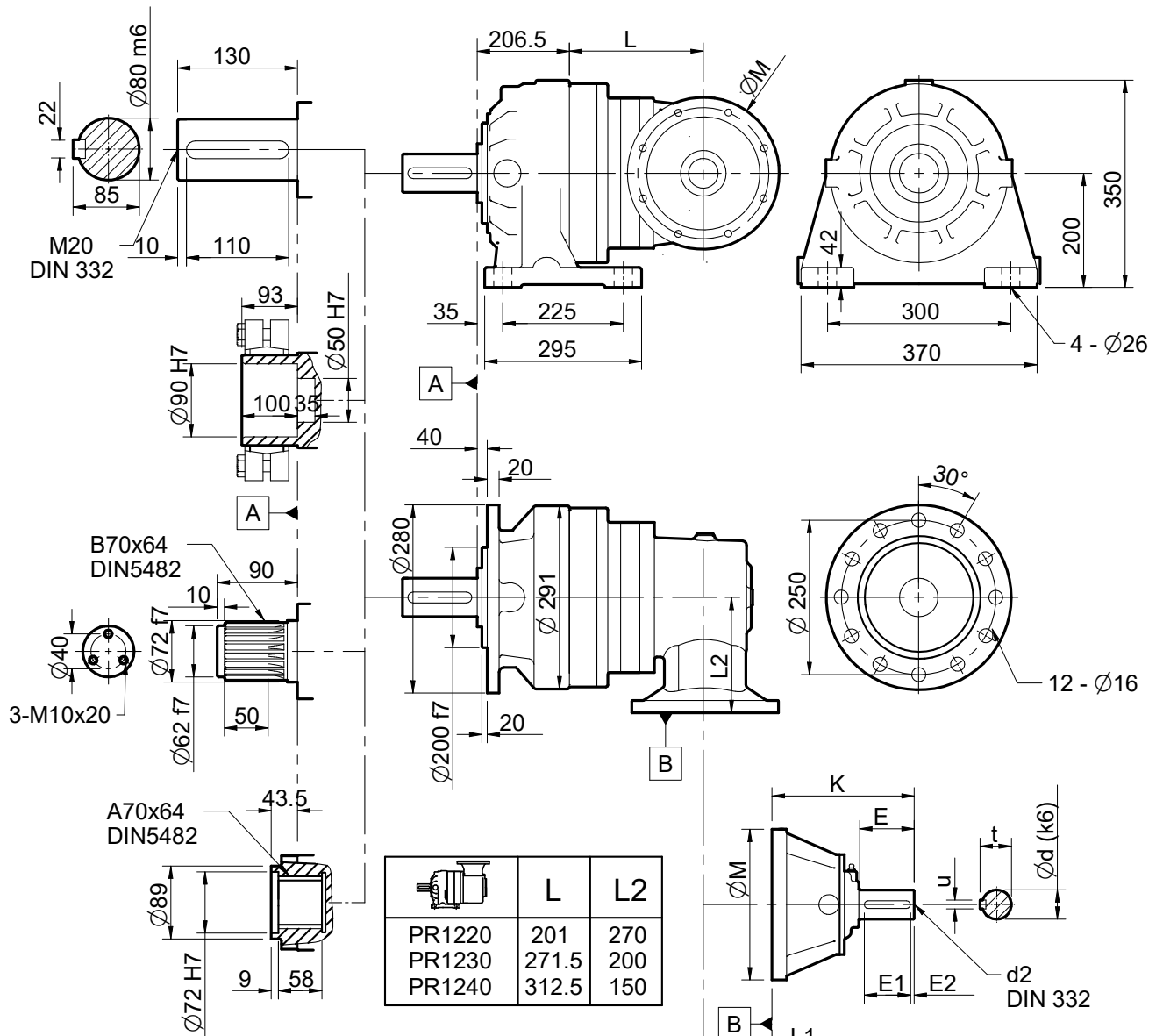

SERIES P

PR16

Series P	Ratio iN	Ratio i	T2 (Nm) n2*h rating						n1 Max	Pt (kW)	
			10,000	25,000	50,000	100,000	500,000	1,000,000		Type B	Type F
PR1620	16.	15.15	12876	12876	12876	12876	10205	8289	2800	48.1	35.7
	20.	18.89	16060	15898	14030	12911	9936	8071		46.9	34.7
	25.	26.39	11138	9395	8310	7996	7327	7025		45.1	33.4
PR1630	56.	55.18	15230	15230	15230	15230	10205	8289	3500	27.6	19.9
	63.	66.10	18243	18243	18243	16539	10205	8289		27.4	19.8
	80.	85.21	21112	19780	18800	16539	10205	8289		27.1	19.5
	100	101.37	21112	19780	18800	16539	10205	8289		26.9	19.4
	112	106.28	18850	15898	14030	12911	9936	8071		26.8	19.4
	125	126.44	18850	15898	14030	12911	9936	8071		26.6	19.2
	140	148.42	11138	9395	8310	7996	7327	7025		26.4	19.1
180	176.59	11138	9395	8310	7996	7327	7025	26.2	18.9		
PR1640	180	173.13	21112	19780	18800	16539	10205	8289	3500	22.5	16.2
	200	209.88	21112	19780	18800	16539	10205	8289		22.4	16.1
	250	251.41	21112	19780	18800	16539	10205	8289		22.3	16.0
	280	276.02	21112	19780	18800	16539	10205	8289		22.2	16.0
	315	333.90	21112	19780	18800	16539	10205	8289		22.1	15.9
	360	344.29	18850	15898	14030	12911	9936	8071		22.1	15.9
	400	399.97	21112	19780	18800	16539	10205	8289		22.0	15.8
	450	426.21	21112	19780	18800	16539	10205	8289		21.9	15.8
	500	515.58	21112	19780	18800	16539	10205	8289		21.8	15.7
	560	531.62	18850	15898	14030	12911	9936	8071		21.8	15.7
	630	613.41	21112	19780	18800	16539	10205	8289		21.7	15.6
	710	765.11	18850	15898	14030	12911	9936	8071		21.6	15.5
	900	898.11	11138	9395	8310	7996	7327	7025		21.5	15.4
11C	1068.52	11138	9395	8310	7996	7327	7025	21.4	15.4		

SERIES P

PR16

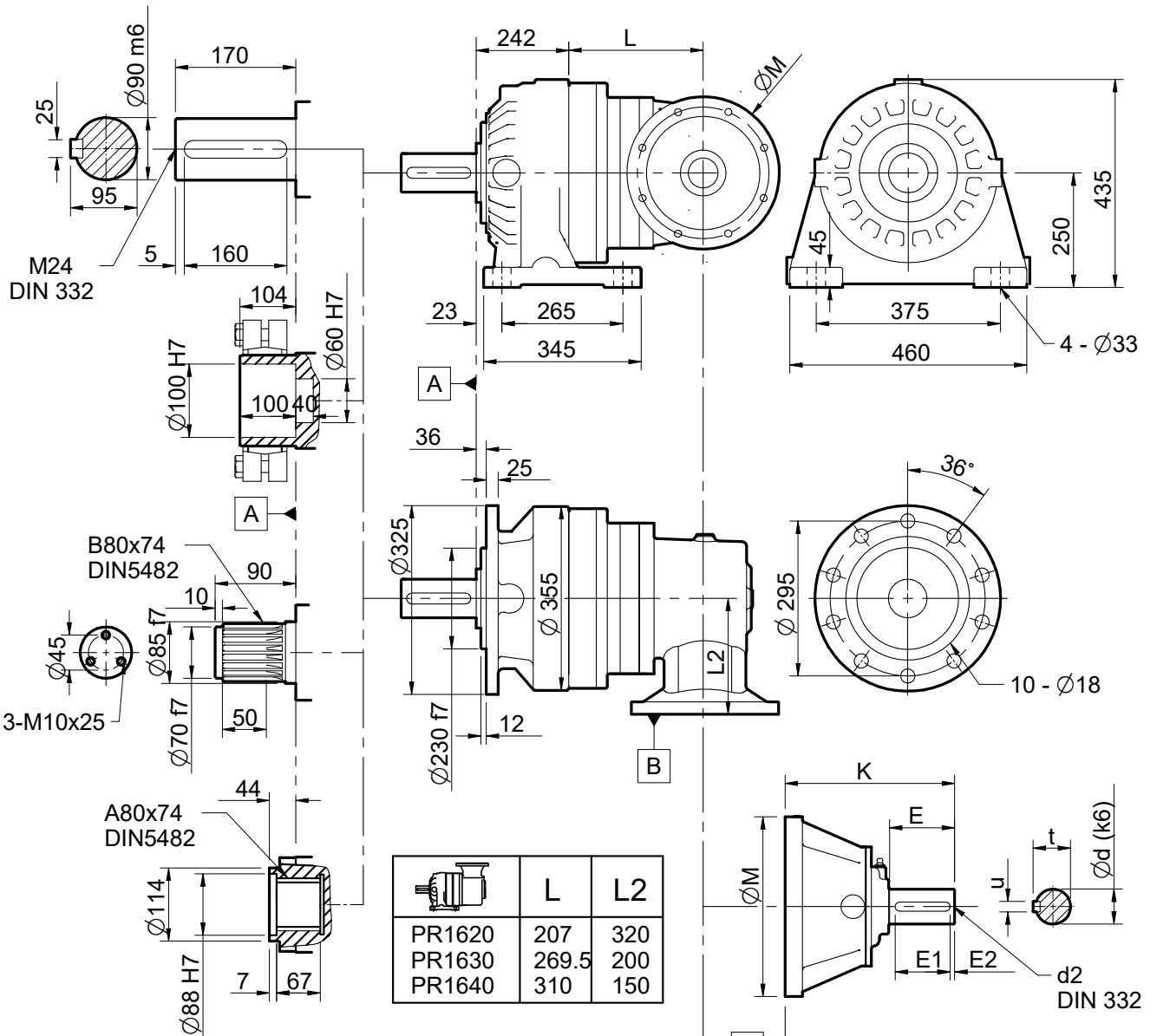

	L	L2
PR1620	207	320
PR1630	269.5	200
PR1640	310	150

	PR1620	PR1630 PR1640
K	228	180
M	240	196
d	48	38
d2	M16	M12
t	51.5	41
u	14	10
E	82	70
E1	70	60
E2	6	5

	PR1620		PR1630 PR1640	
	L1	ØP	L1	ØP
63	-	-	62	140
71	-	-	66	160
80	-	-	80	200
90	-	-	80	200
100-112	-	-	91	250
132	140	300	108	300
160	156	350	-	-
180	156	350	-	-

SERIES P

PR25

Series P	Ratio iN	Ratio i	T2 (Nm) n2*h rating						n1 Max	Pt (kW) Type B	Pt (kW) Type F
			10,000	25,000	50,000	100,000	500,000	1,000,000			
PR2530	56.	56.96	32468	29569	26126	23350	15648	12710	3500	-	23.9
	63.	68.23	32666	29569	26126	23350	15648	12710		-	23.7
	71.	74.05	25385	21500	18990	17657	15258	12394		-	23.6
	90.	87.95	32666	29569	26126	23350	15648	12710		-	23.4
	100	104.64	32666	29569	26126	23350	15648	12710		-	23.2
	112	114.34	25385	21500	18990	17657	15258	12394		-	23.1
	140	136.04	25385	21500	18990	17657	15258	12394		-	23.0
	160	163.51	18707	15813	13944	13339	12250	11780		-	22.8
PR2540	200	207.50	32666	29569	26126	23350	15648	12710	3500	-	18.5
	250	248.56	32666	29569	26126	23350	15648	12710		-	18.4
	280	269.75	25385	21500	18990	17657	15258	12394		-	18.3
	315	320.41	32666	29569	26126	23350	15648	12710		-	18.2
	360	381.20	32666	29569	26126	23350	15648	12710		-	18.1
	400	416.53	25385	21500	18990	17657	15258	12394		-	18.1
	450	456.63	32666	29569	26126	23350	15648	12710		-	18.0
	500	494.74	32666	29569	26126	23350	15648	12710		-	18.0
	560	588.62	32666	29569	26126	23350	15648	12710		-	17.9
	630	643.17	25385	21500	18990	17657	15258	12394		-	17.9
	710	700.31	32666	29569	26126	23350	15648	12710		-	17.8
	800	765.20	25385	21500	18990	17657	15258	12394		-	17.8
	900	910.40	25385	21500	18990	17657	15258	12394		-	17.7
	11C	1094.23	18707	15813	13944	13339	12250	11780		-	17.6

SERIES P

PR25

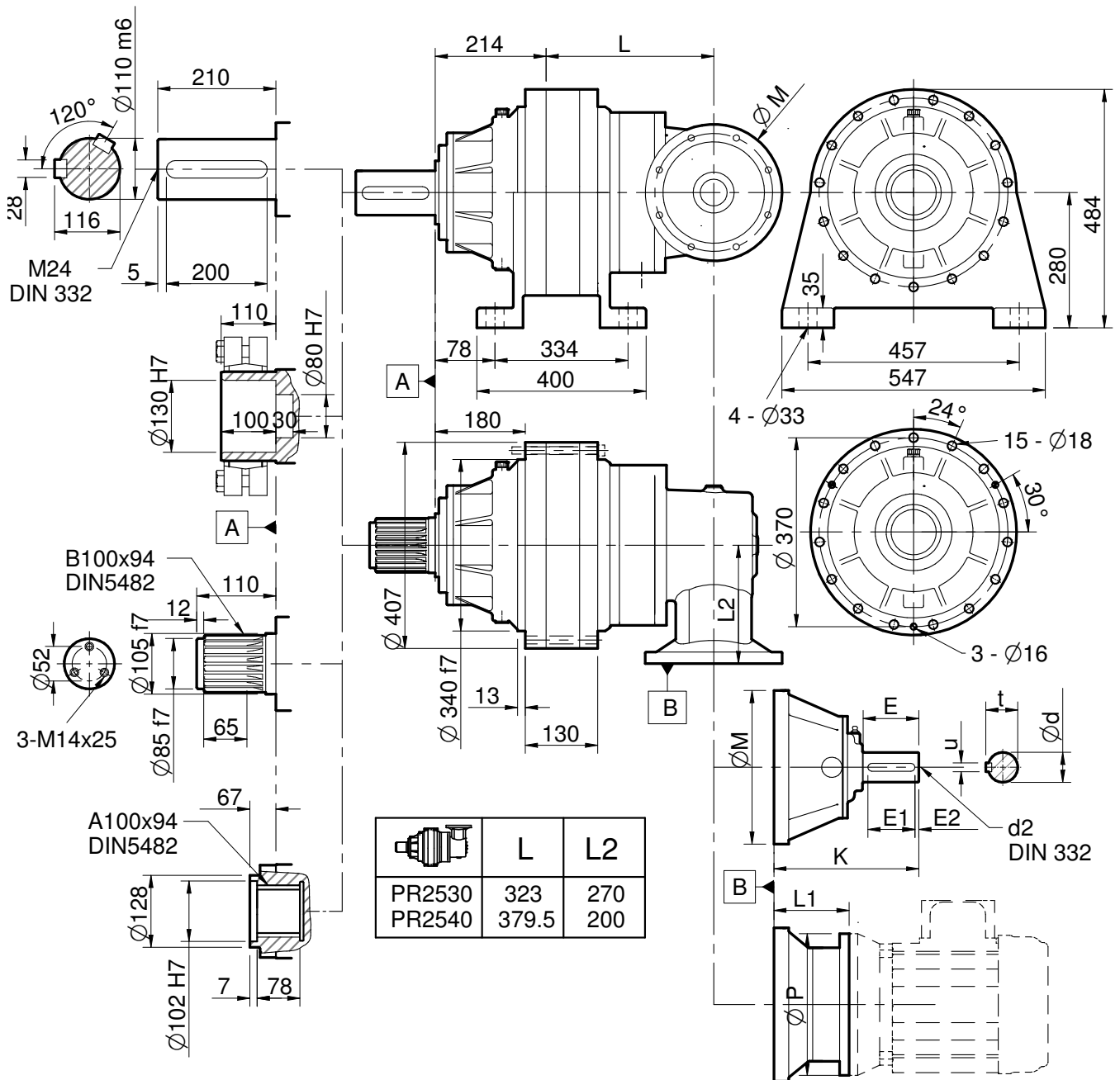

	L	L2
PR2530	323	270
PR2540	379.5	200

	PR2530	PR2540
K	228	180
M	240	196
d	48(k6)	38(k6)
d2	M16	M12
t	51.5	41
u	14	10
E	82	70
E1	70	60
E2	6	5

	PR2530		PR2540	
	L1	ØP	L1	ØP
63	-	-	62	140
71	-	-	66	160
80	-	-	80	200
90	-	-	80	200
100-112	-	-	91	250
132	140	300	108	300
160	156	350	-	-
180	156	350	-	-

SERIES P

PR40

Series P	Ratio iN	Ratio i	T2 (Nm) n2*h rating						n1 Max	Pt (kW) Type B	Pt (kW) Type F
			10,000	25,000	50,000	100,000	500,000	1,000,000			
PR4030	63.	63.23	48787	45398	42760	38509	28637	23260	2800	-	28.5
	71.	78.86	48787	45398	42760	38509	28637	23260		-	28.3
	80.	80.19	40870	34616	30595	28559	26276	22607		-	28.2
	100	100.03	40870	34616	30595	28559	26276	22607		-	28.0
	112	110.13	48787	45398	42760	38509	28637	23260		-	27.8
	125	117.41	33583	28415	25095	23985	22038	21170		-	27.7
	140	139.69	40870	34616	30595	28559	26276	22607		-	27.5
	160	163.97	33583	28415	25095	23985	22038	21170		-	27.3
PR4040	225	230.32	48787	45398	42760	38509	28637	23260	3500	-	22.6
	280	275.89	48787	45398	42760	38509	28637	23260		-	22.5
	315	292.13	40870	34616	30595	28559	26276	22607		-	22.5
	360	355.64	48787	45398	42760	38509	28637	23260		-	22.3
	400	401.20	48787	45398	42760	38509	28637	23260		-	22.2
	450	443.60	48787	45398	42760	38509	28637	23260		-	22.2
	500	508.88	40870	34616	30595	28559	26276	22607		-	22.1
	560	562.65	40870	34616	30595	28559	26276	22607		-	22.1
	630	619.51	48787	45398	42760	38509	28637	23260		-	21.9
	710	737.05	48787	45398	42760	38509	28637	23260		-	21.9
	800	785.77	40870	34616	30595	28559	26276	22607		-	21.8
	900	934.87	40870	34616	30595	28559	26276	22607		-	21.8
	11C	1097.35	33583	28415	25095	23985	22038	21170		-	21.7

SERIES P

PR65

Series P	Ratio <i>i</i> / <i>N</i>	Ratio <i>i</i>	T2 (Nm) n2*h rating						n1 Max	Pt (kW) Type B	Pt (kW) Type F
			10,000	25,000	50,000	100,000	500,000	1,000,000			
PR6540	225	230.32	84700	78850	73150	68250	57443	46658	3500	-	29.4
	280	275.89	84700	78850	73150	68250	57443	46658		-	29.2
	315	320.06	80100	67950	60150	57400	52930	45817		-	29.1
	360	355.64	84700	78850	73150	68250	57443	46658		-	29.0
	400	401.20	84700	78850	73150	68250	57443	46658		-	28.8
	450	443.60	84700	78850	73150	68250	57443	46658		-	28.8
	500	490.86	80100	67950	60150	57400	52930	45817		-	28.7
	560	527.77	84700	78850	73150	68250	57443	46658		-	28.6
	630	612.26	80100	67950	60150	57400	52930	45817		-	28.5
	710	741.81	60700	51460	46370	44680	41080	39480		-	28.4

SERIES P

PR65

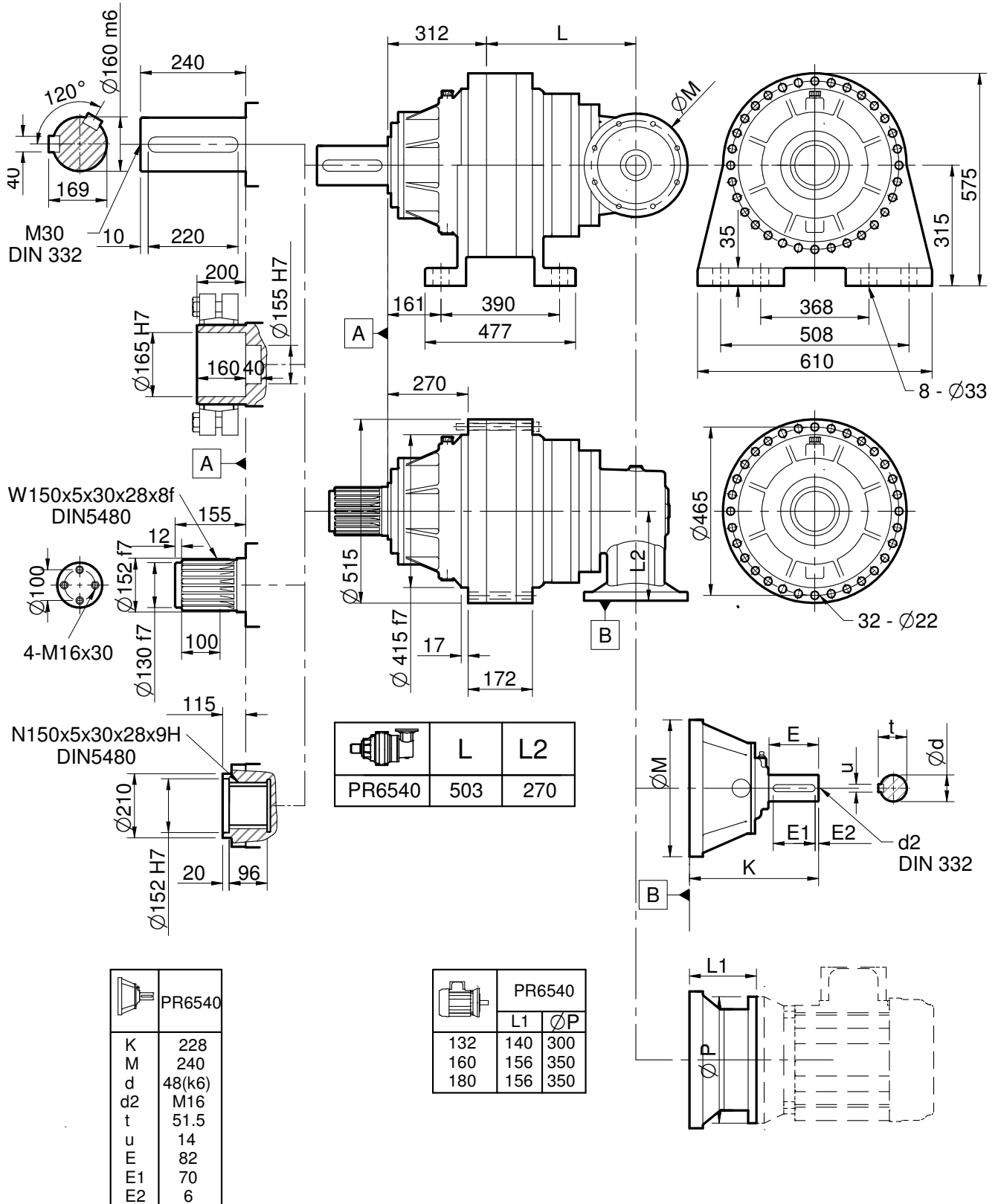

SERIES P

PR MOTORISED RATINGS

	N2	Ratio <i>i</i>	M2 (NM)	fm	FR2 (N)	Unit Designation	Motor Frame	PT(kW) Type B	PT (kW) Type F	
0.12 kW 4 - Pole	7.8	185.5	139	7.97	15000	PR0140180 -M ---.12 A	63	7.3	6.9	
	6.4	224.9	169	6.57	15000	PR0140225 -M ---.12 A	63	7.2	6.8	
	5.3	272.6	205	5.42	15000	PR0140250 -M ---.12 A	63	7.2	6.8	
	4.9	295.7	222	5.00	15000	PR0140280 -M ---.12 A	63	7.2	6.8	
	4.4	330.4	248	3.63	15000	PR0140315 -M ---.12 A	63	7.2	6.7	
	4.1	357.7	269	4.13	15000	PR0140360 -M ---.12 A	63	7.1	6.7	
	3.3	433.7	326	3.41	15000	PR0140400 -M ---.12 A	63	7.1	6.7	
	3.1	471.5	354	3.14	15000	PR0140450 -M ---.12 A	63	7.1	6.7	
	2.8	525.7	395	2.28	15000	PR0140500 -M ---.12 A	63	7.1	6.6	
	2.5	570.3	428	2.59	15000	PR0140560 -M ---.12 A	63	7.0	6.6	
	2.1	689.9	518	2.14	15000	PR0140710 -M ---.12 A	63	7.0	6.6	
	1.7	836.3	628	1.43	15000	PR0140800 -M ---.12 A	63	7.0	6.6	
	1.6	909.3	683	0.92	15000	PR0140900 -M ---.12 A	63	7.0	6.5	
	2.1	689.9	518	3.96	15000	PR0240710 -M ---.12 A	63	7.1	6.7	
	1.7	836.3	628	2.65	15000	PR0240800 -M ---.12 A	63	7.1	6.7	
	1.6	909.3	683	1.70	15000	PR0240900 -M ---.12 A	63	7.1	6.7	
	1.3	1099.9	826	1.41	15000	PR024011C -M ---.12 A	63	7.1	6.6	
	1.1	1330.5	999	0.86	15000	PR024013C -M ---.12 A	63	7.0	6.6	
	1.8	824.9	632	3.18	44500	PR0340800 -M ---.12 A	63	9.3	9.0	
	1.5	997.9	765	2.62	44500	PR034010C -M ---.12 A	63	9.2	9.0	
	1.2	1187.2	910	1.64	44500	PR034012C -M ---.12 A	63	9.2	8.9	
	1.5	997.9	765	4.04	44500	PR054010C -M ---.12 A	63	9.6	9.3	
	1.2	1187.2	910	2.52	44500	PR054012C -M ---.12 A	63	9.5	9.3	
	0.18 kW 4 - Pole	9.9	146.7	167	3.77	15000	PR0130140 -M ---.18 A	63	7.6	7.1
		8.2	177.4	202	2.30	15000	PR0130160 -M ---.18 A	63	7.6	7.1
		7.8	185.5	209	5.31	15000	PR0140180 -M ---.18 A	63	7.3	6.9
		6.4	224.9	253	4.38	15000	PR0140225 -M ---.18 A	63	7.2	6.8
		5.3	272.6	307	3.62	15000	PR0140250 -M ---.18 A	63	7.2	6.8
4.9		295.7	333	3.33	15000	PR0140280 -M ---.18 A	63	7.2	6.8	
4.4		330.4	372	2.42	15000	PR0140315 -M ---.18 A	63	7.2	6.7	
4.1		357.7	403	2.76	15000	PR0140360 -M ---.18 A	63	7.1	6.7	
3.3		433.7	488	2.27	15000	PR0140400 -M ---.18 A	63	7.1	6.7	
3.1		471.5	531	2.09	15000	PR0140450 -M ---.18 A	63	7.1	6.7	
2.8		525.7	592	1.52	15000	PR0140500 -M ---.18 A	63	7.1	6.6	
2.5		570.3	642	1.73	15000	PR0140560 -M ---.18 A	63	7.0	6.6	
2.1		689.9	777	1.43	15000	PR0140710 -M ---.18 A	63	7.0	6.6	
1.7		836.3	942	0.96	15000	PR0140800 -M ---.18 A	63	7.0	6.6	
3.1		471.5	531	3.86	15000	PR0240450 -M ---.18 A	63	7.2	6.8	
2.8		525.7	592	2.81	15000	PR0240500 -M ---.18 A	63	7.2	6.8	
2.5		570.3	642	3.19	15000	PR0240560 -M ---.18 A	63	7.2	6.8	
2.1		689.9	777	2.64	15000	PR0240710 -M ---.18 A	63	7.1	6.7	
1.7		836.3	942	1.76	15000	PR0240800 -M ---.18 A	63	7.1	6.7	
1.6		909.3	1024	1.13	15000	PR0240900 -M ---.18 A	63	7.1	6.7	
1.3		1099.9	1239	0.94	15000	PR024011C -M ---.18 A	63	7.1	6.6	
1.9		774.1	890	3.24	44500	PR0340710 -M ---.18 A	63	9.3	9.0	
1.8		824.9	949	2.12	44500	PR0340800 -M ---.18 A	63	9.3	9.0	
1.5		997.9	1148	1.75	44500	PR034010C -M ---.18 A	63	9.2	9.0	
1.2		1187.2	1365	1.09	44500	PR034012C -M ---.18 A	63	9.2	8.9	
1.8		824.9	949	3.26	44500	PR0540800 -M ---.18 A	63	9.6	9.4	
1.5		997.9	1148	2.69	44500	PR054010C -M ---.18 A	63	9.6	9.3	
1.2		1187.2	1365	1.68	44500	PR054012C -M ---.18 A	63	9.5	9.3	
0.25 kW 4 - Pole	12.0	121.2	192	3.28	15000	PR0130125 -M ---.25 A	71	7.7	7.2	
	9.9	146.7	232	2.71	15000	PR0130140 -M ---.25 A	71	7.6	7.1	
	8.2	177.4	280	1.65	15000	PR0130160 -M ---.25 A	71	7.6	7.1	
	7.8	185.5	290	3.83	15000	PR0140180 -M ---.25 A	71	7.3	6.9	
	6.4	224.9	352	3.16	15000	PR0140225 -M ---.25 A	71	7.2	6.8	
	5.3	272.6	426	2.60	15000	PR0140250 -M ---.25 A	71	7.2	6.8	
	4.9	295.7	463	2.40	15000	PR0140280 -M ---.25 A	71	7.2	6.8	
	4.4	330.4	517	1.74	15000	PR0140315 -M ---.25 A	71	7.2	6.7	
	4.1	357.7	560	1.98	15000	PR0140360 -M ---.25 A	71	7.1	6.7	
	3.3	433.7	678	1.64	15000	PR0140400 -M ---.25 A	71	7.1	6.7	
	3.1	471.5	737	1.51	15000	PR0140450 -M ---.25 A	71	7.1	6.7	
	2.8	525.7	822	1.09	15000	PR0140500 -M ---.25 A	71	7.1	6.6	
	2.5	570.3	892	1.24	15000	PR0140560 -M ---.25 A	71	7.0	6.6	
	2.1	689.9	1079	1.03	15000	PR0140710 -M ---.25 A	71	7.0	6.6	
	4.4	330.4	517	3.21	15000	PR0240315 -M ---.25 A	71	7.3	6.9	
	4.1	357.7	560	3.66	15000	PR0240360 -M ---.25 A	71	7.3	6.9	
	3.3	433.7	678	3.02	15000	PR0240400 -M ---.25 A	71	7.2	6.8	
	3.1	471.5	737	2.78	15000	PR0240450 -M ---.25 A	71	7.2	6.8	
	2.8	525.7	822	2.02	15000	PR0240500 -M ---.25 A	71	7.2	6.8	
	2.5	570.3	892	2.30	15000	PR0240560 -M ---.25 A	71	7.2	6.8	
	2.1	689.9	1079	1.90	15000	PR0240710 -M ---.25 A	71	7.1	6.7	
	1.7	836.3	1308	1.27	15000	PR0240800 -M ---.25 A	71	7.1	6.7	
	1.6	909.3	1422	0.82	15000	PR0240900 -M ---.25 A	71	7.1	6.7	

PR MOTORISED RATINGS

	N2	Ratio <i>i</i>	M2 (NM)	fm	FR2 (N)	Unit Designation	Motor Frame	PT(kW) Type B	PT (kW) Type F
0.25 kW 4 - Pole	3.0	486.6	777	3.71	44500	PR0340500 -M ---.25 A	71	9.4	9.1
	2.7	534.2	853	3.98	44500	PR0340560 -M ---.25 A	71	9.4	9.1
	2.2	646.3	1032	3.29	44500	PR0340630 -M ---.25 A	71	9.4	9.1
	1.9	774.1	1236	2.34	44500	PR0340710 -M ---.25 A	71	9.3	9.0
	1.8	824.9	1318	1.52	44500	PR0340800 -M ---.25 A	71	9.3	9.0
	1.5	997.9	1594	1.26	44500	PR034010C -M ---.25 A	71	9.2	9.0
	1.2	1187.2	1896	0.79	44500	PR034012C -M ---.25 A	71	9.2	8.9
	1.9	774.1	1236	3.59	44500	PR0540710 -M ---.25 A	71	9.7	9.4
	1.8	824.9	1318	2.34	44500	PR0540800 -M ---.25 A	71	9.6	9.4
	1.5	997.9	1594	1.94	44500	PR054010C -M ---.25 A	71	9.6	9.3
1.2	1187.2	1896	1.21	44500	PR054012C -M ---.25 A	71	9.5	9.3	
0.37 kW 4 - Pole	13.0	111.5	261	3.45	15000	PR0130112 -M ---.37 A	71	7.7	7.2
	12.0	121.2	284	2.22	15000	PR0130125 -M ---.37 A	71	7.7	7.2
	9.9	146.7	343	1.83	15000	PR0130140 -M ---.37 A	71	7.6	7.1
	8.2	177.4	415	1.12	15000	PR0130160 -M ---.37 A	71	7.6	7.1
	7.8	185.5	429	2.58	15000	PR0140180 -M ---.37 A	71	7.3	6.9
	6.4	224.9	521	2.13	15000	PR0140225 -M ---.37 A	71	7.2	6.8
	5.3	272.6	631	1.76	15000	PR0140250 -M ---.37 A	71	7.2	6.8
	4.9	295.7	685	1.62	15000	PR0140280 -M ---.37 A	71	7.2	6.8
	4.4	330.4	765	1.18	15000	PR0140315 -M ---.37 A	71	7.2	6.7
	4.1	357.7	828	1.34	15000	PR0140360 -M ---.37 A	71	7.1	6.7
	3.3	433.7	1004	1.11	15000	PR0140400 -M ---.37 A	71	7.1	6.7
	3.1	471.5	1091	1.02	15000	PR0140450 -M ---.37 A	71	7.1	6.7
	2.8	525.7	1217	0.74	15000	PR0140500 -M ---.37 A	71	7.1	6.6
	2.5	570.3	1320	0.84	15000	PR0140560 -M ---.37 A	71	7.0	6.6
	12.0	121.2	284	4.10	15000	PR0230125 -M ---.37 A	71	8.1	7.6
	9.9	146.7	343	3.39	15000	PR0230140 -M ---.37 A	71	8.0	7.5
	8.2	177.4	415	2.06	15000	PR0230160 -M ---.37 A	71	8.0	7.5
	7.8	185.5	429	4.77	15000	PR0240180 -M ---.37 A	71	7.4	7.0
	6.4	224.9	521	3.94	15000	PR0240225 -M ---.37 A	71	7.4	7.0
	5.3	272.6	631	3.25	15000	PR0240250 -M ---.37 A	71	7.3	6.9
	4.9	295.7	685	2.99	15000	PR0240280 -M ---.37 A	71	7.3	6.9
	4.4	330.4	765	2.17	15000	PR0240315 -M ---.37 A	71	7.3	6.9
	4.1	357.7	828	2.48	15000	PR0240360 -M ---.37 A	71	7.3	6.9
	3.3	433.7	1004	2.04	15000	PR0240400 -M ---.37 A	71	7.2	6.8
	3.1	471.5	1091	1.88	15000	PR0240450 -M ---.37 A	71	7.2	6.8
	2.8	525.7	1217	1.36	15000	PR0240500 -M ---.37 A	71	7.2	6.8
	2.5	570.3	1320	1.55	15000	PR0240560 -M ---.37 A	71	7.2	6.8
	2.1	689.9	1597	1.28	15000	PR0240710 -M ---.37 A	71	7.1	6.7
	1.7	836.3	1936	0.96	15000	PR0240800 -M ---.37 A	71	7.1	6.7
	4.7	305.9	723	3.99	44500	PR0340315 -M ---.37 A	71	9.6	9.3
	4.3	335.1	792	4.29	44500	PR0340360 -M ---.37 A	71	9.5	9.2
	3.6	406.2	960	3.54	44500	PR0340400 -M ---.37 A	71	9.5	9.2
	3.3	441.6	1044	3.26	44500	PR0340450 -M ---.37 A	71	9.5	9.2
	3.0	486.6	1150	2.51	44500	PR0340500 -M ---.37 A	71	9.4	9.1
	2.7	534.2	1263	2.69	44500	PR0340560 -M ---.37 A	71	9.4	9.1
	2.2	646.3	1528	2.23	44500	PR0340630 -M ---.37 A	71	9.4	9.1
	1.9	774.1	1830	1.58	44500	PR0340710 -M ---.37 A	71	9.3	9.0
	1.8	824.9	1950	1.03	44500	PR0340800 -M ---.37 A	71	9.3	9.0
	1.5	997.9	2359	0.85	44500	PR034010C -M ---.37 A	71	9.2	9.0
	3.0	486.6	1150	3.86	44500	PR0540500 -M ---.37 A	71	9.8	9.5
	2.7	534.2	1263	4.14	44500	PR0540560 -M ---.37 A	71	9.8	9.5
	2.2	646.3	1528	3.42	44500	PR0540630 -M ---.37 A	71	9.7	9.4
	1.9	774.1	1830	2.43	44500	PR0540710 -M ---.37 A	71	9.7	9.4
	1.8	824.9	1950	1.58	44500	PR0540800 -M ---.37 A	71	9.6	9.4
	1.5	997.9	2359	1.31	44500	PR054010C -M ---.37 A	71	9.6	9.3
	1.2	1187.2	2806	0.82	44500	PR054012C -M ---.37 A	71	9.5	9.3
	1.9	748.4	1757	3.58	52000	PR0840800 -M ---.37 A	71	12.9	12.2
	1.6	890.4	2090	3.04	52000	PR0840900 -M ---.37 A	71	12.8	12.1
	1.3	1059.4	2487	2.18	52000	PR084011C -M ---.37 A	71	12.8	12.1
	1.9	748.4	1769	4.07	52000	PR1240800 -M ---.37 A	71	13.5	12.8
1.6	890.4	2105	3.42	52000	PR1240900 -M ---.37 A	71	13.5	12.8	
1.4	1059.4	2504	2.43	52000	PR124011C -M ---.37 A	71	13.4	12.7	
1.6	898.1	2123	3.77	54000	PR1640900 -M ---.37 A	71	21.5	15.4	
1.4	1068.5	2526	3.17	54000	PR164011C -M ---.37 A	71	21.4	15.4	
0.55 kW 4 - Pole	20.7	70.1	244	3.69	15000.0	PR013071. -M ---.55 A	80	7.9	7.3
	19.1	76.0	264	4.20	15000.0	PR013080. -M ---.55 A	80	7.8	7.3
	15.8	92.0	320	3.47	15000.0	PR013090. -M ---.55 A	80	7.8	7.3
	13.0	111.5	388	2.32	15000.0	PR0130112 -M ---.55 A	80	7.7	7.2
	12.0	121.2	422	1.49	15000.0	PR0130125 -M ---.55 A	80	7.7	7.2
	9.9	146.7	510	1.23	15000.0	PR0130140 -M ---.55 A	80	7.6	7.1
	8.2	177.4	617	0.75	15000.0	PR0130160 -M ---.55 A	80	7.6	7.1
	7.8	185.5	638	1.74	15000.0	PR0140180 -M ---.55 A	80	7.3	6.9
	6.4	224.9	774	1.43	15000.0	PR0140225 -M ---.55 A	80	7.2	6.8
	5.3	272.6	938	1.18	15000.0	PR0140250 -M ---.55 A	80	7.2	6.8
	4.9	295.7	1018	1.09	15000.0	PR0140280 -M ---.55 A	80	7.2	6.8
	4.4	330.4	1137	0.79	15000.0	PR0140315 -M ---.55 A	80	7.2	6.7
	4.1	357.7	1231	0.90	15000.0	PR0140360 -M ---.55 A	80	7.1	6.7

SERIES P

PR MOTORISED RATINGS

	N2	Ratio <i>i</i>	M2 (NM)	fm	FR2 (N)	Unit Designation	Motor Frame	PT(kW) Type B	PT (kW) Type F
0.55 kW	12.0	121.2	422	2.76	15000	PR0230125 -M ---.55 A	80	8.1	7.6
	9.9	146.7	510	2.28	15000	PR0230140 -M ---.55 A	80	8.0	7.5
	8.2	177.4	617	1.39	15000	PR0230160 -M ---.55 A	80	8.0	7.5
	4 - Pole								
	7.8	185.5	638	3.21	15000	PR0240180 -M ---.55 A	80	7.4	7.0
	6.4	224.9	774	2.65	15000	PR0240225 -M ---.55 A	80	7.4	7.0
	5.3	272.6	938	2.19	15000	PR0240250 -M ---.55 A	80	7.3	6.9
	4.9	295.7	1018	2.01	15000	PR0240280 -M ---.55 A	80	7.3	6.9
	4.4	330.4	1137	1.46	15000	PR0240315 -M ---.55 A	80	7.3	6.9
	4.1	357.7	1231	1.67	15000	PR0240360 -M ---.55 A	80	7.3	6.9
	3.3	433.7	1492	1.37	15000	PR0240400 -M ---.55 A	80	7.2	6.8
	3.1	471.5	1622	1.26	15000	PR0240450 -M ---.55 A	80	7.2	6.8
	2.8	525.7	1809	0.92	15000	PR0240500 -M ---.55 A	80	7.2	6.8
	2.5	570.3	1963	1.04	15000	PR0240560 -M ---.55 A	80	7.2	6.8
	2.1	689.9	2374	0.86	15000	PR0240710 -M ---.55 A	80	7.1	6.7
	5.7	255.3	897	3.79	44500	PR0340250 -M ---.55 A	80	9.6	9.3
	5.2	277.0	973	3.49	44500	PR0340280 -M ---.55 A	80	9.6	9.3
	4.7	305.9	1075	2.69	44500	PR0340315 -M ---.55 A	80	9.6	9.3
	4.3	335.1	1177	2.89	44500	PR0340360 -M ---.55 A	80	9.5	9.2
	3.6	406.2	1427	2.38	44500	PR0340400 -M ---.55 A	80	9.5	9.2
	3.3	441.6	1552	2.19	44500	PR0340450 -M ---.55 A	80	9.5	9.2
	3.0	486.6	1710	1.69	44500	PR0340500 -M ---.55 A	80	9.4	9.1
	2.7	534.2	1877	1.81	44500	PR0340560 -M ---.55 A	80	9.4	9.1
	2.2	646.3	2271	1.50	44500	PR0340630 -M ---.55 A	80	9.4	9.1
	1.9	774.1	2720	1.06	44500	PR0340710 -M ---.55 A	80	9.3	9.0
	3.6	406.2	1427	3.66	44500	PR0540400 -M ---.55 A	80	9.8	9.6
	3.3	441.6	1552	3.37	44500	PR0540450 -M ---.55 A	80	9.8	9.5
	3.0	486.6	1710	2.60	44500	PR0540500 -M ---.55 A	80	9.8	9.5
	2.7	534.2	1877	2.79	44500	PR0540560 -M ---.55 A	80	9.8	9.5
	2.2	646.3	2271	2.30	44500	PR0540630 -M ---.55 A	80	9.7	9.4
	1.9	774.1	2720	1.63	44500	PR0540710 -M ---.55 A	80	9.7	9.4
	1.8	824.9	2899	1.07	44500	PR0540800 -M ---.55 A	80	9.6	9.4
	1.5	997.9	3506	0.88	44500	PR054010C -M ---.55 A	80	9.6	9.3
	2.3	618.7	2182	2.85	52000	PR0840630 -M ---.55 A	80	13.0	12.3
	2.1	690.8	2436	3.73	52000	PR0840710 -M ---.55 A	80	12.9	12.2
	1.9	748.4	2639	2.38	52000	PR0840800 -M ---.55 A	80	12.9	12.2
	1.6	890.4	3140	2.02	52000	PR0840900 -M ---.55 A	80	12.8	12.1
	1.3	1059.4	3736	1.45	52000	PR084011C -M ---.55 A	80	12.8	12.1
	2.3	618.7	2174	3.31	52000	PR1240630 -M ---.55 A	80	13.6	12.9
	2.1	690.8	2427	4.12	52000	PR1240710 -M ---.55 A	80	13.6	12.9
	1.9	748.4	2630	2.74	52000	PR1240800 -M ---.55 A	80	13.5	12.8
	1.6	890.4	3129	2.30	52000	PR1240900 -M ---.55 A	80	13.5	12.8
	1.4	1059.4	3722	1.63	52000	PR124011C -M ---.55 A	80	13.4	12.7
	1.6	898.1	3156	2.53	54000	PR1640900 -M ---.55 A	80	21.5	15.4
	1.4	1068.5	3754	2.13	54000	PR164011C -M ---.55 A	80	21.4	15.4
	1.3	1094.2	3845	3.47	80000	PR254011C -M ---.55 A	80	-	18
0.75 kW	30.4	47.7	226	4.91	15000	PR013045. -M ---.75 A	80	8.0	7.5
	25.1	57.8	274	4.05	15000	PR013056. -M ---.75 A	80	7.9	7.4
	20.7	70.1	332	2.71	15000	PR013071. -M ---.75 A	80	7.9	7.3
	19.1	76.0	361	3.08	15000	PR013080. -M ---.75 A	80	7.8	7.3
15.8	92.0	436	2.54	15000	PR013090. -M ---.75 A	80	7.8	7.3	
13.0	111.5	529	1.70	15000	PR0130112 -M ---.75 A	80	7.7	7.2	
12.0	121.2	575	1.09	15000	PR0130125 -M ---.75 A	80	7.7	7.2	
9.9	146.7	695	0.90	15000	PR0130140 -M ---.75 A	80	7.6	7.1	
8.2	177.4	841	0.55	15000	PR0130160 -M ---.75 A	80	7.6	7.1	
	7.8	185.5	870	1.28	15000	PR0140180 -M ---.75 A	80	7.3	6.9
	6.4	224.9	1055	1.05	15000	PR0140225 -M ---.75 A	80	7.2	6.8
	5.3	272.6	1279	0.87	15000	PR0140250 -M ---.75 A	80	7.2	6.8
	4.9	295.7	1388	0.80	15000	PR0140280 -M ---.75 A	80	7.2	6.8
	13.0	111.5	529	3.14	15000	PR0230112 -M ---.75 A	80	8.1	7.6
	12.0	121.2	575	2.02	15000	PR0230125 -M ---.75 A	80	8.1	7.6
	9.9	146.7	695	1.67	15000	PR0230140 -M ---.75 A	80	8.0	7.5
	8.2	177.4	841	1.02	15000	PR0230160 -M ---.75 A	80	8.0	7.5
	7.8	185.5	870	2.36	15000	PR0240180 -M ---.75 A	80	7.4	7.0
	6.4	224.9	1055	1.94	15000	PR0240225 -M ---.75 A	80	7.4	7.0
	5.3	272.6	1279	1.60	15000	PR0240250 -M ---.75 A	80	7.3	6.9
	4.9	295.7	1388	1.48	15000	PR0240280 -M ---.75 A	80	7.3	6.9
	4.4	330.4	1551	1.07	15000	PR0240315 -M ---.75 A	80	7.3	6.9
	4.1	357.7	1679	1.22	15000	PR0240360 -M ---.75 A	80	7.3	6.9
	3.3	433.7	2035	1.01	15000	PR0240400 -M ---.75 A	80	7.2	6.8
	3.1	471.5	2212	0.93	15000	PR0240450 -M ---.75 A	80	7.2	6.8

PR MOTORISED RATINGS

	N2	Ratio <i>i</i>	M2 (NM)	fm	FR2 (N)	Unit Designation	Motor Frame	PT(kW) Type B	PT (kW) Type F	
0.75 kW 4 - Pole	8.3	173.8	833	4.08	44500	PR0340180 - M ---.75 A	80	9.7	9.4	
	6.9	210.6	1009	3.37	44500	PR0340200 - M ---.75 A	80	9.7	9.4	
	5.7	255.3	1223	2.78	44500	PR0340250 - M ---.75 A	80	9.6	9.3	
	5.2	277.0	1327	2.56	44500	PR0340280 - M ---.75 A	80	9.6	9.3	
	4.7	305.9	1466	1.97	44500	PR0340315 - M ---.75 A	80	9.6	9.3	
	4.3	335.1	1606	2.12	44500	PR0340360 - M ---.75 A	80	9.5	9.2	
	3.6	406.2	1946	1.75	44500	PR0340400 - M ---.75 A	80	9.5	9.2	
	3.3	441.6	2116	1.61	44500	PR0340450 - M ---.75 A	80	9.5	9.2	
	3.0	486.6	2331	1.24	44500	PR0340500 - M ---.75 A	80	9.4	9.1	
	2.7	534.2	2560	1.33	44500	PR0340560 - M ---.75 A	80	9.4	9.1	
	2.2	646.3	3097	1.10	44500	PR0340630 - M ---.75 A	80	9.4	9.1	
	5.2	277.0	1327	3.94	44500	PR0540280 - M ---.75 A	80	10.0	9.7	
	4.7	305.9	1466	3.03	44500	PR0540315 - M ---.75 A	80	9.9	9.6	
	4.3	335.1	1606	3.26	44500	PR0540360 - M ---.75 A	80	9.9	9.6	
	3.6	406.2	1946	2.69	44500	PR0540400 - M ---.75 A	80	9.8	9.6	
	3.3	441.6	2116	2.47	44500	PR0540450 - M ---.75 A	80	9.8	9.5	
	3.0	486.6	2331	1.91	44500	PR0540500 - M ---.75 A	80	9.8	9.5	
	2.7	534.2	2560	2.04	44500	PR0540560 - M ---.75 A	80	9.8	9.5	
	2.2	646.3	3097	1.69	44500	PR0540630 - M ---.75 A	80	9.7	9.4	
	1.9	774.1	3709	1.20	44500	PR0540710 - M ---.75 A	80	9.7	9.4	
	1.8	824.9	3953	0.78	44500	PR0540800 - M ---.75 A	80	9.6	9.4	
	2.5	576.7	2773	3.76	52000	PR0840560 - M ---.75 A	80	13.0	12.3	
	2.3	618.7	2975	2.09	52000	PR0840630 - M ---.75 A	80	13.0	12.3	
	2.1	690.8	3321	2.74	52000	PR0840710 - M ---.75 A	80	12.9	12.2	
	1.9	748.4	3599	1.75	52000	PR0840800 - M ---.75 A	80	12.9	12.2	
	1.6	890.4	4282	1.48	52000	PR0840900 - M ---.75 A	80	12.8	12.1	
	1.3	1059.4	5094	1.07	52000	PR084011C - M ---.75 A	80	12.8	12.1	
	2.5	576.7	2763	4.08	52000	PR1240560 - M ---.75 A	80	13.6	12.9	
	2.3	618.7	2964	2.43	52000	PR1240630 - M ---.75 A	80	13.6	12.9	
	2.1	690.8	3310	3.02	52000	PR1240710 - M ---.75 A	80	13.6	12.9	
	1.9	748.4	3586	2.01	52000	PR1240800 - M ---.75 A	80	13.5	12.8	
	1.6	890.4	4266	1.69	52000	PR1240900 - M ---.75 A	80	13.5	12.8	
	1.4	1059.4	5076	1.20	52000	PR124011C - M ---.75 A	80	13.4	12.7	
	1.9	765.1	3666	3.52	54000	PR1640710 - M ---.75 A	80	21.6	15.5	
	1.6	898.1	4303	1.86	54000	PR1640900 - M ---.75 A	80	21.5	15.4	
	1.4	1068.5	5120	1.56	54000	PR164011C - M ---.75 A	80	21.4	15.4	
	1.6	910.4	4362	4.05	80000	PR2540900 - M ---.75 A	80	-	17.7	
	1.3	1094.2	5243	2.54	80000	PR254011C - M ---.75 A	80	-	17.6	
	1.1 kW 4 - Pole	118.2	12.3	86	12.88	6191	PR012012. - M ---.1.1 A	90	9.5	8.8
		97.5	14.9	104	8.61	7504	PR012014. - M ---.1.1 A	90	9.3	8.6
		74.2	19.6	137	4.58	9869	PR012018. - M ---.1.1 A	90	9.1	8.4
		61.3	23.7	166	2.79	11939	PR012022. - M ---.1.1 A	90	8.9	8.3
		30.4	47.7	332	3.35	15000	PR013045. - M ---.1.1 A	90	8.0	7.5
		25.1	57.8	402	2.76	15000	PR013056. - M ---.1.1 A	90	7.9	7.4
		20.7	70.1	487	1.85	15000	PR013071. - M ---.1.1 A	90	7.9	7.3
		19.1	76.0	529	2.10	15000	PR013080. - M ---.1.1 A	90	7.8	7.3
		15.8	92.0	640	1.73	15000	PR013090. - M ---.1.1 A	90	7.8	7.3
13.0		111.5	776	1.16	15000	PR0130112 - M ---.1.1 A	90	7.7	7.2	
20.7		70.1	487	3.41	15000	PR023071. - M ---.1.1 A	90	8.3	7.8	
19.1		76.0	529	3.88	15000	PR023080. - M ---.1.1 A	90	8.3	7.8	
15.8		92.0	640	3.20	15000	PR023090. - M ---.1.1 A	90	8.2	7.7	
13.0		111.5	776	2.14	15000	PR0230112 - M ---.1.1 A	90	8.1	7.6	
12.0		121.2	843	1.38	15000	PR0230125 - M ---.1.1 A	90	8.1	7.6	
9.9		146.7	1020	1.14	15000	PR0230140 - M ---.1.1 A	90	8.0	7.5	
8.2		177.4	1234	0.69	15000	PR0230160 - M ---.1.1 A	90	8.0	7.5	
7.8		185.5	1277	1.61	15000	PR0240180 - M ---.1.1 A	90	7.4	7.0	
6.4		224.9	1548	1.32	15000	PR0240225 - M ---.1.1 A	90	7.4	7.0	
5.3		272.6	1876	1.09	15000	PR0240250 - M ---.1.1 A	90	7.3	6.9	
4.9		295.7	2035	1.01	15000	PR0240280 - M ---.1.1 A	90	7.3	6.9	
4.4		330.4	2274	0.73	15000	PR0240315 - M ---.1.1 A	90	7.3	6.9	
4.1		357.7	2462	0.83	15000	PR0240360 - M ---.1.1 A	90	7.3	6.9	
14.0		103.2	725	4.0	44500	PR0330100 - M ---.1.1 A	90	10.9	10.5	
13.2		110.0	773	2.6	44500	PR0330112 - M ---.1.1 A	90	10.8	10.5	
10.9		133.1	935	2.1	44500	PR0330140 - M ---.1.1 A	90	10.7	10.4	
9.2		158.3	1112	1.3	44500	PR0330160 - M ---.1.1 A	90	10.7	10.3	
8.3		173.8	1221	2.78	44500	PR0340180 - M ---.1.1 A	90	9.7	9.4	
6.9		210.6	1480	2.30	44500	PR0340200 - M ---.1.1 A	90	9.7	9.4	
5.7		255.3	1794	1.89	44500	PR0340250 - M ---.1.1 A	90	9.6	9.3	
5.2		277.0	1947	1.75	44500	PR0340280 - M ---.1.1 A	90	9.6	9.3	
4.7		305.9	2149	1.34	44500	PR0340315 - M ---.1.1 A	90	9.6	9.3	
4.3		335.1	2355	1.44	44500	PR0340360 - M ---.1.1 A	90	9.5	9.2	
3.6		406.2	2855	1.19	44500	PR0340400 - M ---.1.1 A	90	9.5	9.2	
3.3		441.6	3104	1.10	44500	PR0340450 - M ---.1.1 A	90	9.5	9.2	
3.0		486.6	3420	0.84	44500	PR0340500 - M ---.1.1 A	90	9.4	9.1	
2.7		534.2	3754	0.91	44500	PR0340560 - M ---.1.1 A	90	9.4	9.1	

SERIES P

PR MOTORISED RATINGS

	N2	Ratio <i>i</i>	M2 (NM)	fm	FR2 (N)	Unit Designation	Motor Frame	PT(kW) Type B	PT (kW) Type F
1.1 kW	13.2	110.0	773	4.00	44500	PR0530112 - M ---1.1 A	90	11.3	10.9
	10.9	133.1	935	3.30	44500	PR0530140 - M ---1.1 A	90	11.2	10.8
	9.2	158.3	1112	2.07	44500	PR0530160 - M ---1.1 A	90	11.1	10.8
4 - Pole	8.3	173.8	1221	4.28	44500	PR0540180 - M ---1.1 A	90	10.1	9.8
	6.9	210.6	1480	3.53	44500	PR0540200 - M ---1.1 A	90	10.0	9.7
	5.7	255.3	1794	2.92	44500	PR0540250 - M ---1.1 A	90	10.0	9.7
	5.2	277.0	1947	2.69	44500	PR0540280 - M ---1.1 A	90	10.0	9.7
	4.7	305.9	2149	2.07	44500	PR0540315 - M ---1.1 A	90	9.9	9.6
	4.3	335.1	2355	2.22	44500	PR0540360 - M ---1.1 A	90	9.9	9.6
	3.6	406.2	2855	1.83	44500	PR0540400 - M ---1.1 A	90	9.8	9.6
	3.3	441.6	3104	1.69	44500	PR0540450 - M ---1.1 A	90	9.8	9.5
	3.0	486.6	3420	1.30	44500	PR0540500 - M ---1.1 A	90	9.8	9.5
	2.7	534.2	3754	1.39	44500	PR0540560 - M ---1.1 A	90	9.8	9.5
	2.2	646.3	4542	1.15	44500	PR0540630 - M ---1.1 A	90	9.7	9.4
	1.9	774.1	5440	0.82	44500	PR0540710 - M ---1.1 A	90	9.7	9.4
	3.8	376.0	2652	3.83	52000	PR0840360 - M --- 1.1 A	90	13.1	12.4
	3.6	400.7	2826	3.61	52000	PR0840400 - M ---1.1 A	90	13.1	12.4
	3.2	450.4	3176	2.78	52000	PR0840450 - M --- 1.1 A	90	13.1	12.4
	3.0	484.7	3418	3.02	52000	PR0840500 - M --- 1.1 A	90	13.0	12.3
	2.5	576.7	4067	2.57	52000	PR0840560 - M ---1.1 A	90	13.0	12.3
	2.3	618.7	4363	1.42	52000	PR0840630 - M --- 1.1 A	90	13.0	12.3
	2.1	690.8	4871	1.86	52000	PR0840710 - M --- 1.1 A	90	12.9	12.2
	1.9	748.4	5278	1.19	52000	PR0840800 - M --- 1.1 A	90	12.9	12.2
	1.6	890.4	6280	1.01	52000	PR0840900 - M --- 1.1 A	90	12.8	12.1
	3.6	400.7	2816	4.00	52000	PR1240400 - M ---1.1 A	90	13.8	13.1
	3.2	450.4	3165	3.16	52000	PR1240450 - M ---1.1 A	90	13.7	13.0
	3.0	484.7	3406	3.31	52000	PR1240500 - M ---1.1 A	90	13.7	13.0
	2.5	576.7	4052	2.78	52000	PR1240560 - M ---1.1 A	90	13.6	12.9
	2.3	618.7	4348	1.66	52000	PR1240630 - M ---1.1 A	90	13.6	12.9
	2.1	690.8	4854	2.06	52000	PR1240710 - M ---1.1 A	90	13.6	12.9
	1.9	748.4	5260	1.37	52000	PR1240800 - M ---1.1 A	90	13.5	12.8
	1.6	890.4	6257	1.15	52000	PR1240900 - M ---1.1 A	90	13.5	12.8
1.4	1059.4	7445	0.82	52000	PR124011C - M ---1.1 A	90	13.4	12.7	
2.7	531.6	3736	3.46	54000	PR1640560 - M ---1.1 A	90	21.8	15.7	
2.4	613.4	4311	3.84	54000	PR1640630 - M ---1.1 A	90	21.7	15.6	
1.9	765.1	5377	2.40	54000	PR1640710 - M ---1.1 A	90	21.6	15.5	
1.6	898.1	6311	1.27	54000	PR1640900 - M ---1.1 A	90	21.5	15.4	
1.4	1068.5	7509	1.06	54000	PR164011C - M ---1.1 A	90	21.4	15.4	
2.3	643.2	4520	3.91	80000	PR2540630 - M ---1.1 A	90	-	17.9	
2.1	700.3	4921	4.74	80000	PR2540710 - M ---1.1 A	90	-	17.8	
1.9	765.2	5377	3.28	80000	PR2540800 - M ---1.1 A	90	-	17.8	
1.6	910.4	6398	2.76	80000	PR2540900 - M ---1.1 A	90	-	17.7	
1.3	1094.2	7690	1.73	80000	PR254011C - M ---1.1 A	90	-	17.6	
1.6	934.9	6570	4.35	110000	PR4040900 - M ---1.1 A	90	-	21.8	
1.3	1097.4	7712	3.11	110000	PR404011C - M ---1.1 A	90	-	21.7	
1.5 kW	118.2	12.3	118	9.44	6191	PR012012. - M ---1.5 A	90	9.5	8.8
	97.5	14.9	142	6.32	7504	PR012014. - M ---1.5 A	90	9.3	8.6
	74.2	19.6	187	3.36	9869	PR012018. - M ---1.5 A	90	9.1	8.4
4 - Pole	61.3	23.7	227	2.05	11939	PR012022. - M ---1.5 A	90	8.9	8.3
	30.4	47.7	452	2.45	15000	PR013045. - M ---1.5 A	90	8.0	7.5
	25.1	57.8	548	2.02	15000	PR013056. - M ---1.5 A	90	7.9	7.4
	20.7	70.1	665	1.35	15000	PR013071. - M ---1.5 A	90	7.9	7.3
	19.1	76.0	721	1.54	15000	PR013080. - M ---1.5 A	90	7.8	7.3
	15.8	92.0	872	1.27	15000	PR013090. - M ---1.5 A	90	7.8	7.3
	13.0	111.5	1058	0.85	15000	PR0130112 - M ---1.5 A	90	7.7	7.2
	25.1	57.8	548	3.74	15000	PR023056. - M ---1.5 A	90	8.4	7.9
	20.7	70.1	665	2.50	15000	PR023071. - M ---1.5 A	90	8.3	7.8
	19.1	76.0	721	2.84	15000	PR023080. - M ---1.5 A	90	8.3	7.8
	15.8	92.0	872	2.35	15000	PR023090. - M ---1.5 A	90	8.2	7.7
	13.0	111.5	1058	1.57	15000	PR0230112 - M ---1.5 A	90	8.1	7.6
	12.0	121.2	1150	1.01	15000	PR0230125 - M ---1.5 A	90	8.1	7.6
	9.9	146.7	1391	0.84	15000	PR0230140 - M ---1.5 A	90	8.0	7.5
	8.2	177.4	1683	0.51	15000	PR0230160 - M ---1.5 A	90	8.0	7.5
	7.8	185.5	1741	1.18	15000	PR0240180 - M ---1.5 A	90	7.4	7.0
	6.4	224.9	2110	0.97	15000	PR0240225 - M ---1.5 A	90	7.4	7.0
	5.3	272.6	2558	0.80	15000	PR0240250 - M ---1.5 A	90	7.3	6.9
	16.8	86.2	826	4.12	44500	PR033090. - M ---1.5 A	90	10.9	10.6
	14.0	103.2	989	2.92	44500	PR0330100 - M ---1.5 A	90	10.9	10.5
	13.2	110.0	1054	1.91	44500	PR0330112 - M ---1.5 A	90	10.8	10.5
	10.9	133.1	1275	1.57	44500	PR0330140 - M ---1.5 A	90	10.7	10.4
	9.2	158.3	1517	0.98	44500	PR0330160 - M ---1.5 A	90	10.7	10.3
	8.3	173.8	1665	2.04	44500	PR0340180 - M ---1.5 A	90	9.7	9.4
	6.9	210.6	2018	1.68	44500	PR0340200 - M ---1.5 A	90	9.7	9.4
	5.7	255.3	2447	1.39	44500	PR0340250 - M ---1.5 A	90	9.6	9.3

PR MOTORISED RATINGS

	N2	Ratio <i>i</i>	M2 (NM)	fm	FR2 (N)	Unit Designation	Motor Frame	PT(kW) Type B	PT (kW) Type F
1.5 kW 4 - Pole	5.2	277.0	2655	1.28	44500	PR0340280 - M ---1.5 A	90	9.6	9.3
	4.7	305.9	2931	0.98	44500	PR0340315 - M ---1.5 A	90	9.6	9.3
	4.3	335.1	3211	1.06	44500	PR0340360 - M ---1.5 A	90	9.5	9.2
	3.6	406.2	3893	0.87	44500	PR0340400 - M ---1.5 A	90	9.5	9.2
	3.3	441.6	4232	0.80	44500	PR0340450 - M ---1.5 A	90	9.5	9.2
	13.2	110.0	1054	2.93	44500	PR0530112 - M ---1.5 A	90	11.3	10.9
	10.9	133.1	1275	2.42	44500	PR0530140 - M ---1.5 A	90	11.2	10.8
	9.2	158.3	1517	1.51	44500	PR0530160 - M ---1.5 A	90	11.1	10.8
	8.3	173.8	1665	3.14	44500	PR0540180 - M ---1.5 A	90	10.1	9.8
	6.9	210.6	2018	2.59	44500	PR0540200 - M ---1.5 A	90	10.0	9.7
	5.7	255.3	2447	2.14	44500	PR0540250 - M ---1.5 A	90	10.0	9.7
	5.2	277.0	2655	1.97	44500	PR0540 280 - M --- 1.5 A	90	10.0	9.7
	4.7	305.9	2931	1.52	44500	PR0540 315 - M --- 1.5 A	90	9.9	9.6
	4.3	335.1	3211	1.63	44500	PR0540 360 - M --- 1.5 A	90	9.9	9.6
	3.6	406.2	3893	1.34	44500	PR0540 400 - M --- 1.5 A	90	9.8	9.6
	3.3	441.6	4232	1.24	44500	PR0540 450 - M --- 1.5 A	90	9.8	9.5
	3.0	486.6	4663	0.95	44500	PR0540 500 - M --- 1.5 A	90	9.8	9.5
	2.7	534.2	5120	1.02	44500	PR0540 560 - M --- 1.5 A	90	9.8	9.5
	2.2	646.3	6193	0.84	44500	PR0540 630 - M --- 1.5 A	90	9.7	9.4
	5.5	259.5	2495	3.98	52000	PR0840 250 - M --- 1.5 A	90	13.3	12.6
	5.1	283.1	2723	3.15	52000	PR0840 280 - M --- 1.5 A	90	13.3	12.5
	4.6	313.9	3019	3.33	52000	PR0840 315 - M --- 1.5 A	90	13.2	12.5
	3.8	376.0	3616	2.81	52000	PR0840 360 - M --- 1.5 A	90	13.1	12.4
	3.6	400.7	3853	2.65	52000	PR0840 400 - M --- 1.5 A	90	13.1	12.4
	3.2	450.4	4331	2.04	52000	PR0840 450 - M --- 1.5 A	90	13.1	12.4
	3.0	484.7	4661	2.22	52000	PR0840 500 - M --- 1.5 A	90	13.0	12.3
	2.5	576.7	5546	1.88	52000	PR0840 560 - M --- 1.5 A	90	13.0	12.3
	2.3	618.7	5950	1.04	52000	PR0840 630 - M --- 1.5 A	90	13.0	12.3
	2.1	690.8	6643	1.37	52000	PR0840 710 - M --- 1.5 A	90	12.9	12.2
	1.9	748.4	7197	0.87	52000	PR0840 800 - M --- 1.5 A	90	12.9	12.2
	5.1	283.1	2713	3.68	52000	PR1240 280 - M --- 1.5 A	90	13.9	13.2
	4.6	313.9	3008	3.75	52000	PR1240 315 - M --- 1.5 A	90	13.9	13.2
	3.9	376.0	3603	3.13	52000	PR1240 360 - M --- 1.5 A	90	13.8	13.1
	3.6	400.7	3840	2.94	52000	PR1240 400 - M --- 1.5 A	90	13.8	13.1
	3.2	450.4	4316	2.32	52000	PR1240 450 - M --- 1.5 A	90	13.7	13.0
	3.0	484.7	4645	2.43	52000	PR1240 500 - M --- 1.5 A	90	13.7	13.0
	2.5	576.7	5526	2.04	52000	PR1240 560 - M --- 1.5 A	90	13.6	12.9
	2.3	618.7	5929	1.21	52000	PR1240 630 - M --- 1.5 A	90	13.6	12.9
	2.1	690.8	6619	1.51	52000	PR1240 710 - M --- 1.5 A	90	13.6	12.9
	1.9	748.4	7172	1.00	52000	PR1240 800 - M --- 1.5 A	90	13.5	12.8
	1.6	890.4	8533	0.84	52000	PR1240 900 - M --- 1.5 A	90	13.5	12.8
	1.4	1059.4	10152	0.60	52000	PR1240 11C - M --- 1.5 A	90	13.4	12.7
	3.4	426.2	4084	4.05	54000	PR1640 450 - M --- 1.5 A	90	21.9	15.8
	2.8	515.6	4941	3.35	54000	PR1640 500 - M --- 1.5 A	90	21.8	15.7
	2.7	531.6	5094	2.53	54000	PR1640 560 - M --- 1.5 A	90	21.8	15.7
	2.4	613.4	5878	2.81	54000	PR1640 630 - M --- 1.5 A	90	21.7	15.6
	1.9	765.1	7332	1.76	54000	PR1640 710 - M --- 1.5 A	90	21.6	15.5
	1.6	898.1	8606	0.93	54000	PR1640 900 - M --- 1.5 A	90	21.5	15.4
	2.5	588.6	5641	4.14	80000	PR2540 560 - M --- 1.5 A	90	-	17.9
	2.3	643.2	6163	2.86	80000	PR2540 630 - M --- 1.5 A	90	-	17.9
2.1	700.3	6711	3.48	80000	PR2540 710 - M --- 1.5 A	90	-	17.8	
1.9	765.2	7333	2.41	80000	PR2540 800 - M --- 1.5 A	90	-	17.8	
1.6	910.4	8724	2.02	80000	PR2540 900 - M --- 1.5 A	90	-	17.7	
1.3	1094.2	10486	1.27	80000	PR2540 11C - M --- 1.5 A	90	-	17.6	
1.8	785.8	7530	3.79	110000	PR4040 800 - M --- 1.5 A	90	-	21.8	
1.6	934.9	8959	3.19	110000	PR4040 900 - M --- 1.5 A	90	-	21.8	
1.3	1097.4	10516	2.28	110000	PR4040 11C - M --- 1.5 A	90	-	21.7	
2.2 kW 4 - Pole	118.2	12.3	172	6.44	6191	PR0120 12. - M --- 2.2 A	100	9.5	8.8
	97.5	14.9	209	4.31	7504	PR0120 14. - M --- 2.2 A	100	9.3	8.6
	74.2	19.6	275	2.29	9869	PR0120 18. - M --- 2.2 A	100	9.1	8.4
	61.3	23.7	332	1.40	11939	PR0120 22. - M --- 2.2 A	100	8.9	8.3
	30.4	47.7	663	1.67	15000	PR0130 45. - M --- 2.2 A	100	8.0	7.5
	25.1	57.8	804	1.38	15000	PR0130 56. - M --- 2.2 A	100	7.9	7.4
	20.7	70.1	975	0.92	15000	PR0130 71. - M --- 2.2 A	100	7.9	7.3
	19.1	76.0	1058	1.05	15000	PR0130 80. - M --- 2.2 A	100	7.8	7.3
	15.8	92.0	1280	0.87	15000	PR0130 90. - M --- 2.2 A	100	7.8	7.3
	74.2	19.6	275	4.23	9869	PR0220 18. - M --- 2.2 A	100	9.3	8.6
	61.3	23.7	332	2.57	11939	PR0220 22. - M --- 2.2 A	100	9.1	8.5
	30.4	47.7	663	3.09	15000	PR0230 45. - M --- 2.2 A	100	8.5	7.9
	25.1	57.8	804	2.55	15000	PR0230 56. - M --- 2.2 A	100	8.4	7.9
	20.7	70.1	975	1.70	15000	PR0230 71. - M --- 2.2 A	100	8.3	7.8
	19.1	76.0	1058	1.94	15000	PR0230 80. - M --- 2.2 A	100	8.3	7.8
	15.8	92.0	1280	1.60	15000	PR0230 90. - M --- 2.2 A	100	8.2	7.7
	13.0	111.5	1551	1.07	15000	PR0230 112 - M --- 2.2 A	100	8.1	7.6

SERIES P

PR MOTORISED RATINGS

	N2	Ratio <i>i</i>	M2 (NM)	fm	FR2 (N)	Unit Designation	Motor Frame	PT(kW) Type B	PT (kW) Type F
2.2 kW 4 - Pole	26.8	54.2	761	4.47	44500	PR033056. -M --- 2.2 A	100	11.2	10.8
	22.3	64.9	912	3.17	44500	PR033063. -M --- 2.2 A	100	11.1	10.7
	20.4	71.2	1001	3.40	44500	PR033071. -M --- 2.2 A	100	11.0	10.7
	16.8	86.2	1211	2.81	44500	PR033090. -M --- 2.2 A	100	10.9	10.6
	14.0	103.2	1451	1.99	44500	PR0330100 -M --- 2.2 A	100	10.9	10.5
	13.2	110.0	1546	1.30	44500	PR0330112 -M --- 2.2 A	100	10.8	10.5
	10.9	133.1	1870	1.07	44500	PR0330140 -M --- 2.2 A	100	10.7	10.4
	8.3	173.8	2442	1.39	44500	PR0340180 -M --- 2.2 A	100	9.7	9.4
	6.9	210.6	2960	1.15	44500	PR0340200 -M --- 2.2 A	100	9.7	9.4
	5.7	255.3	3589	0.95	44500	PR0340250 -M --- 2.2 A	100	9.6	9.3
5.2	277.0	3893	0.87	44500	PR0340280 -M --- 2.2 A	100	9.6	9.3	
26.8	54.2	1384	3.78	44500	PR053056. -M --- 2.2 A	112	11.6	11.3	
22.3	64.9	1658	2.68	44500	PR053063. -M --- 2.2 A	112	11.5	11.2	
20.4	71.2	1820	2.87	44500	PR053071. -M --- 2.2 A	112	11.5	11.1	
16.8	86.2	2202	2.38	44500	PR053090. -M --- 2.2 A	112	11.4	11.0	
14.0	103.2	2638	1.68	44500	PR0530100 -M --- 2.2 A	112	11.3	11.0	
13.2	110.0	2811	1.10	44500	PR0530112 -M --- 2.2 A	112	11.3	10.9	
10.9	133.1	3400	0.91	44500	PR0530140 -M --- 2.2 A	112	11.2	10.8	
8.3	173.8	4440	1.18	44500	PR0540180 -M --- 2.2 A	112	10.1	9.8	
6.9	210.6	5383	0.97	44500	PR0540200 -M --- 2.2 A	112	10.0	9.7	
5.7	255.3	6525	0.80	44500	PR0540250 -M --- 2.2 A	112	10.0	9.7	
11.7	123.7	1720	3.26	52000	PR0830125 -M --- 2.2 A	100	16.2	15.3	
9.9	147.2	2047	2.77	52000	PR0830140 -M --- 2.2 A	100	16.1	15.2	
8.3	175.1	2435	1.99	52000	PR0830180 -M --- 2.2 A	100	15.9	15.1	
8.9	162.8	2264	4.25	52000	PR0840180 -M --- 2.2 A	100	13.5	12.8	
7.3	197.3	2745	3.55	52000	PR0840200 -M --- 2.2 A	100	13.4	12.7	
6.1	236.3	3288	3.00	52000	PR0840225 -M --- 2.2 A	100	13.3	12.6	
5.6	259.5	3609	2.75	52000	PR0840250 -M --- 2.2 A	100	13.3	12.6	
5.1	283.1	3938	2.18	52000	PR0840280 -M --- 2.2 A	100	13.3	12.5	
4.6	313.9	4366	2.30	52000	PR0840315 -M --- 2.2 A	100	13.2	12.5	
3.9	376.0	5230	1.94	52000	PR0840360 -M --- 2.2 A	100	13.1	12.4	
3.6	400.7	5573	1.83	52000	PR0840400 -M --- 2.2 A	100	13.1	12.4	
3.2	450.4	6265	1.41	52000	PR0840450 -M --- 2.2 A	100	13.1	12.4	
3.0	484.7	6742	1.53	52000	PR0840500 -M --- 2.2 A	100	13.0	12.3	
2.5	576.7	8021	1.30	52000	PR0840560 -M --- 2.2 A	100	13.0	12.3	
11.7	123.7	1738	4.14	52000	PR1230125 -M --- 2.2 A	100	16.8	16.0	
9.9	147.2	2068	3.48	52000	PR1230140 -M --- 2.2 A	100	16.7	15.8	
8.3	175.1	2461	2.47	52000	PR1230180 -M --- 2.2 A	100	16.6	15.7	
8.9	162.8	2288	4.93	52000	PR1240180 -M --- 2.2 A	100	14.2	13.4	
7.3	197.3	2773	4.07	52000	PR1240200 -M --- 2.2 A	100	14.1	13.4	
6.1	236.3	3322	3.39	52000	PR1240225 -M --- 2.2 A	100	14.0	13.3	
5.6	259.5	3647	3.09	52000	PR1240250 -M --- 2.2 A	100	14.0	13.2	
5.1	283.1	3979	2.51	52000	PR1240280 -M --- 2.2 A	100	13.9	13.2	
4.6	313.9	4412	2.56	52000	PR1240315 -M --- 2.2 A	100	13.9	13.2	
3.9	376.0	5285	2.13	52000	PR1240360 -M --- 2.2 A	100	13.8	13.1	
3.6	400.7	5632	2.00	52000	PR1240400 -M --- 2.2 A	100	13.8	13.1	
3.2	450.4	6330	1.58	52000	PR1240450 -M --- 2.2 A	100	13.7	13.0	
3.0	484.7	6812	1.66	52000	PR1240500 -M --- 2.2 A	100	13.7	13.0	
2.5	576.7	8105	1.39	52000	PR1240560 -M --- 2.2 A	100	13.6	12.9	
2.3	618.7	8696	0.83	52000	PR1240630 -M --- 2.2 A	100	13.6	12.9	
2.1	690.8	9709	1.03	52000	PR1240710 -M --- 2.2 A	100	13.6	12.9	
4.3	333.9	4693	3.52	54000	PR1640315 -M --- 2.2 A	100	22.1	15.9	
4.2	344.3	4839	2.67	54000	PR1640360 -M --- 2.2 A	100	22.1	15.9	
3.6	400.0	5621	2.94	54000	PR1640400 -M --- 2.2 A	100	22.0	15.8	
3.4	426.2	5990	2.76	54000	PR1640450 -M --- 2.2 A	100	21.9	15.8	
2.8	515.6	7246	2.28	54000	PR1640500 -M --- 2.2 A	100	21.8	15.7	
2.7	531.6	7472	1.73	54000	PR1640560 -M --- 2.2 A	100	21.8	15.7	
2.4	613.4	8621	1.92	54000	PR1640630 -M --- 2.2 A	100	21.7	15.6	
1.9	765.1	10754	1.20	54000	PR1640710 -M --- 2.2 A	100	21.6	15.5	
3.5	416.5	5854	3.02	80000	PR2540400 -M --- 2.2 A	100	-	18.1	
3.2	456.6	6418	3.64	80000	PR2540450 -M --- 2.2 A	100	-	18.0	
2.9	494.7	6954	3.36	80000	PR2540500 -M --- 2.2 A	100	-	18.0	
2.5	588.6	8273	2.82	80000	PR2540560 -M --- 2.2 A	100	-	17.9	
2.3	643.2	9040	1.95	80000	PR2540630 -M --- 2.2 A	100	-	17.9	
2.1	700.3	9843	2.37	80000	PR2540710 -M --- 2.2 A	100	-	17.8	
1.9	765.2	10755	1.64	80000	PR2540800 -M --- 2.2 A	100	-	17.8	
1.6	910.4	12796	1.38	80000	PR2540900 -M --- 2.2 A	100	-	17.7	
1.3	1094.2	15379	0.87	80000	PR254011C -M --- 2.2 A	100	-	17.6	
2.0	737.1	10359	3.72	110000	PR4040710 -M --- 2.2 A	100	-	21.9	
1.8	785.8	11044	2.59	110000	PR4040800 -M --- 2.2 A	100	-	21.8	
1.6	934.9	13139	2.17	110000	PR4040900 -M --- 2.2 A	100	-	21.8	
1.3	1097.4	15423	1.56	110000	PR404011C -M --- 2.2 A	100	-	21.7	

PR MOTORISED RATINGS

	N2	Ratio <i>i</i>	M2 (NM)	fm	FR2 (N)	Unit Designation	Motor Frame	PT(kW) Type B	PT (kW) Type F
3.0 kW 4 - Pole	118.2	12.3	235	4.72	6191	PR012012. - M --- 3.0 A	100	9.5	8.8
	97.5	14.9	285	3.16	7504	PR012014. - M --- 3.0 A	100	9.3	8.6
	74.2	19.6	375	1.68	9869	PR012018. - M --- 3.0 A	100	9.1	8.4
	61.3	23.7	453	1.02	11939	PR012022. - M --- 3.0 A	100	8.9	8.3
	30.4	47.7	905	1.23	15000	PR013045. - M --- 3.0 A	100	8.0	7.5
	25.1	57.8	1097	1.01	15000	PR013056. - M --- 3.0 A	100	7.9	7.4
	74.2	19.6	375	3.10	9869	PR022018. - M --- 3.0 A	100	9.3	8.6
	61.3	23.7	453	1.89	11939	PR022022. - M --- 3.0 A	100	9.1	8.5
	30.4	47.7	905	2.27	15000	PR023045. - M --- 3.0 A	100	8.5	7.9
	25.1	57.8	1097	1.87	15000	PR023056. - M --- 3.0 A	100	8.4	7.9
20.7	70.1	1330	1.25	15000	PR023071. - M --- 3.0 A	100	8.3	7.8	
19.1	76.0	1442	1.42	15000	PR023080. - M --- 3.0 A	100	8.3	7.8	
15.8	92.0	1745	1.17	15000	PR023090. - M --- 3.0 A	100	8.2	7.7	
13.0	111.5	2115	0.80	15000	PR0230112. - M --- 3.0 A	100	8.1	7.6	
55.4	26.2	501	2.98	40302	PR032025. - M --- 3.0 A	100	14.5	14.1	
32.5	44.7	856	3.97	44500	PR033045. - M --- 3.0 A	100	11.3	10.9	
26.8	54.2	1038	3.28	44500	PR033056. - M --- 3.0 A	100	11.2	10.8	
22.3	64.9	1243	2.32	44500	PR033063. - M --- 3.0 A	100	11.1	10.7	
20.4	71.2	1365	2.49	44500	PR033071. - M --- 3.0 A	100	11.0	10.7	
16.8	86.2	1651	2.06	44500	PR033090. - M --- 3.0 A	100	10.9	10.6	
14.0	103.2	1978	1.46	44500	PR0330100. - M --- 3.0 A	100	10.9	10.5	
13.2	110.0	2108	0.95	44500	PR0330112. - M --- 3.0 A	100	10.8	10.5	
10.9	133.1	2550	0.79	44500	PR0330140. - M --- 3.0 A	100	10.7	10.4	
8.3	173.8	3330	1.02	44500	PR0340180. - M --- 3.0 A	100	9.7	9.4	
6.9	210.6	4037	0.84	44500	PR0340200. - M --- 3.0 A	100	9.7	9.4	
22.3	64.9	1243	3.57	44500	PR053063. - M --- 3.0 A	100	11.5	11.2	
20.4	71.2	1365	3.83	44500	PR053071. - M --- 3.0 A	100	11.5	11.1	
16.8	86.2	1651	3.17	44500	PR053090. - M --- 3.0 A	100	11.4	11.0	
14.0	103.2	1978	2.25	44500	PR0530100. - M --- 3.0 A	100	11.3	11.0	
13.2	110.0	2108	1.47	44500	PR0530112. - M --- 3.0 A	100	11.3	10.9	
10.9	133.1	2550	1.21	44500	PR0530140. - M --- 3.0 A	100	11.2	10.8	
9.2	158.3	3034	0.76	44500	PR0530160. - M --- 3.0 A	100	11.1	10.8	
8.3	173.8	3330	1.57	44500	PR0540180. - M --- 3.0 A	100	10.1	9.8	
6.9	210.6	4037	1.30	44500	PR0540200. - M --- 3.0 A	100	10.0	9.7	
5.7	255.3	4894	1.07	44500	PR0540250. - M --- 3.0 A	100	10.0	9.7	
5.2	277.0	5309	0.99	44500	PR0540280. - M --- 3.0 A	100	10.0	9.7	
4.7	305.9	5862	0.76	44500	PR0540315. - M --- 3.0 A	100	9.9	9.6	
4.3	335.1	6422	0.81	44500	PR0540360. - M --- 3.0 A	100	9.9	9.6	
12.7	114.2	2165	3.74	52000	PR0830112. - M --- 3.0 A	100	16.2	15.4	
11.7	123.7	2346	2.39	52000	PR0830125. - M --- 3.0 A	100	16.2	15.3	
9.9	147.2	2791	2.03	52000	PR0830140. - M --- 3.0 A	100	16.1	15.2	
8.3	175.1	3321	1.46	52000	PR0830180. - M --- 3.0 A	100	15.9	15.1	
8.9	162.8	3087	3.12	52000	PR0840180. - M --- 3.0 A	100	13.5	12.8	
7.3	197.3	3743	2.60	52000	PR0840200. - M --- 3.0 A	100	13.4	12.7	
6.1	236.3	4483	2.20	52000	PR0840225. - M --- 3.0 A	100	13.3	12.6	
5.6	259.5	4922	2.02	52000	PR0840250. - M --- 3.0 A	100	13.3	12.6	
5.1	283.1	5370	1.60	52000	PR0840280. - M --- 3.0 A	100	13.3	12.5	
4.6	313.9	5954	1.69	52000	PR0840315. - M --- 3.0 A	100	13.2	12.5	
3.9	376.0	7132	1.42	52000	PR0840360. - M --- 3.0 A	100	13.1	12.4	
3.6	400.7	7600	1.34	52000	PR0840400. - M --- 3.0 A	100	13.1	12.4	
3.2	450.4	8543	1.03	52000	PR0840450. - M --- 3.0 A	100	13.1	12.4	
3.0	484.7	9194	1.12	52000	PR0840500. - M --- 3.0 A	100	13.0	12.3	
2.5	576.7	10938	0.95	52000	PR0840560. - M --- 3.0 A	100	13.0	12.3	
11.7	123.7	2371	3.04	52000	PR1230125. - M --- 3.0 A	100	16.8	16.0	
9.9	147.2	2820	2.55	52000	PR1230140. - M --- 3.0 A	100	16.7	15.8	
8.3	175.1	3355	1.81	52000	PR1230180. - M --- 3.0 A	100	16.6	15.7	
8.9	162.8	3119	3.61	52000	PR1240180. - M --- 3.0 A	100	14.2	13.4	
7.3	197.3	3782	2.98	52000	PR1240200. - M --- 3.0 A	100	14.1	13.4	
6.1	236.3	4530	2.49	52000	PR1240225. - M --- 3.0 A	100	14.0	13.3	
5.6	259.5	4973	2.27	52000	PR1240250. - M --- 3.0 A	100	14.0	13.2	
5.1	283.1	5426	1.84	52000	PR1240280. - M --- 3.0 A	100	13.9	13.2	
4.6	313.9	6016	1.87	52000	PR1240315. - M --- 3.0 A	100	13.9	13.2	
3.9	376.0	7206	1.56	52000	PR1240360. - M --- 3.0 A	100	13.8	13.1	
3.6	400.7	7679	1.47	52000	PR1240400. - M --- 3.0 A	100	13.8	13.1	
3.2	450.4	8632	1.16	52000	PR1240450. - M --- 3.0 A	100	13.7	13.0	
3.0	484.7	9290	1.21	52000	PR1240500. - M --- 3.0 A	100	13.7	13.0	
2.5	576.7	11052	1.02	52000	PR1240560. - M --- 3.0 A	100	13.6	12.9	
9.8	148.4	2845	2.81	54000	PR1630140. - M --- 3.0 A	100	26.4	19.1	
8.2	176.6	3384	2.36	54000	PR1630180. - M --- 3.0 A	100	26.2	18.9	

SERIES P

PR MOTORISED RATINGS

	N2	Ratio <i>i</i>	M2 (NM)	fm	FR2 (N)	Unit Designation	Motor Frame	PT(kW) Type B	PT (kW) Type F	
3.0 kW 4 - Pole	5.8	251.4	4818	3.43	54000	PR1640250 - M --- 3.0 A	100	22.3	16.0	
	5.3	276.0	5290	3.13	54000	PR1640280 - M --- 3.0 A	100	22.2	16.0	
	4.3	333.9	6399	2.58	54000	PR1640315 - M --- 3.0 A	100	22.1	15.9	
	4.2	344.3	6599	1.96	54000	PR1640360 - M --- 3.0 A	100	22.1	15.9	
	3.6	400.0	7666	2.16	54000	PR1640400 - M --- 3.0 A	100	22.0	15.8	
	3.4	426.2	8169	2.02	54000	PR1640450 - M --- 3.0 A	100	21.9	15.8	
	2.8	515.6	9882	1.67	54000	PR1640500 - M --- 3.0 A	100	21.8	15.7	
	2.7	531.6	10189	1.27	54000	PR1640560 - M --- 3.0 A	100	21.8	15.7	
	2.4	613.4	11756	1.41	54000	PR1640630 - M --- 3.0 A	100	21.7	15.6	
	1.9	765.1	14664	0.88	54000	PR1640710 - M --- 3.0 A	100	21.6	15.5	
	5.4	269.8	5170	3.42	80000	PR2540280 - M --- 3.0 A	100	-	18.3	
	4.5	320.4	6141	3.80	80000	PR2540315 - M --- 3.0 A	100	-	18.2	
	3.8	381.2	7306	3.20	80000	PR2540360 - M --- 3.0 A	100	-	18.1	
	3.5	416.5	7983	2.21	80000	PR2540400 - M --- 3.0 A	100	-	18.1	
	3.2	456.6	8752	2.67	80000	PR2540450 - M --- 3.0 A	100	-	18.0	
	2.9	494.7	9482	2.46	80000	PR2540500 - M --- 3.0 A	100	-	18.0	
	2.5	588.6	11281	2.07	80000	PR2540560 - M --- 3.0 A	100	-	17.9	
	2.3	643.2	12327	1.43	80000	PR2540630 - M --- 3.0 A	100	-	17.9	
	2.1	700.3	13422	1.74	80000	PR2540710 - M --- 3.0 A	100	-	17.8	
	1.9	765.2	14666	1.20	80000	PR2540800 - M --- 3.0 A	100	-	17.8	
	1.6	910.4	17449	1.01	80000	PR2540900 - M --- 3.0 A	100	-	17.7	
	2.8	508.9	9753	2.9	110000	PR4040500 - M --- 3.0 A	100	-	22.1	
	2.6	562.7	10784	2.6	110000	PR4040560 - M --- 3.0 A	100	-	22.1	
	2.3	619.5	11873	3.2	110000	PR4040630 - M --- 3.0 A	100	-	21.9	
	2.0	737.1	14126	2.7	110000	PR4040710 - M --- 3.0 A	100	-	21.9	
	1.8	785.8	15060	1.9	110000	PR4040800 - M --- 3.0 A	100	-	21.8	
	1.6	934.9	17917	1.6	110000	PR4040900 - M --- 3.0 A	100	-	21.8	
	1.3	1097.4	21032	1.1	110000	PR404011C - M --- 3.0 A	100	-	21.7	
	4.0 kW 4 - Pole	118.2	12.3	313	3.54	6191	PR012012. - M --- 4.0 A	112	9.5	8.8
		97.5	14.9	380	2.37	7504	PR012014. - M --- 4.0 A	112	9.3	8.6
		74.2	19.6	500	1.26	9869	PR012018. - M --- 4.0 A	112	9.1	8.4
		61.3	23.7	604	0.77	11939	PR012022. - M --- 4.0 A	112	8.9	8.3
		118.2	12.3	313	5.09	6191	PR022012. - M --- 4.0 A	112	9.7	9.0
		97.5	14.9	380	4.37	7504	PR022014. - M --- 4.0 A	112	9.5	8.9
		74.2	19.6	500	2.33	9869	PR022018. - M --- 4.0 A	112	9.3	8.6
		61.3	23.7	604	1.42	11939	PR022022. - M --- 4.0 A	112	9.1	8.5
		30.4	47.7	1206	1.70	15000	PR022045. - M --- 4.0 A	112	8.5	7.9
		25.1	57.8	1462	1.40	15000	PR022056. - M --- 4.0 A	112	8.4	7.9
		20.7	70.1	1773	0.94	15000	PR022071. - M --- 4.0 A	112	8.3	7.8
		19.1	76.0	1923	1.07	15000	PR022080. - M --- 4.0 A	112	8.3	7.8
		15.8	92.0	2326	0.88	15000	PR022090. - M --- 4.0 A	112	8.2	7.7
		65.9	22.0	562	3.57	33875	PR032022. - M --- 4.0 A	112	14.8	14.3
55.4		26.2	669	2.23	40302	PR032025. - M --- 4.0 A	112	14.5	14.1	
32.5		44.7	1142	2.98	44500	PR033045. - M --- 4.0 A	112	11.3	10.9	
26.8		54.2	1384	2.46	44500	PR033056. - M --- 4.0 A	112	11.2	10.8	
22.3		64.9	1658	1.74	44500	PR033063. - M --- 4.0 A	112	11.1	10.7	
20.4		71.2	1820	1.87	44500	PR033071. - M --- 4.0 A	112	11.0	10.7	
16.8		86.2	2202	1.54	44500	PR033090. - M --- 4.0 A	112	10.9	10.6	
14.0		103.2	2638	1.09	44500	PR0330100 - M --- 4.0 A	112	10.9	10.5	
65.9		22.0	562	5.50	33875	PR052022. - M --- 4.0 A	112	15.1	14.7	
55.4		26.2	669	3.44	40302	PR052025. - M --- 4.0 A	112	14.9	14.4	
32.5		44.7	1142	4.58	44500	PR053045. - M --- 4.0 A	112	11.7	11.4	
26.8		54.2	1384	3.78	44500	PR053056. - M --- 4.0 A	112	11.6	11.3	
22.3		64.9	1658	2.68	44500	PR053063. - M --- 4.0 A	112	11.5	11.2	
20.4		71.2	1820	2.87	44500	PR053071. - M --- 4.0 A	112	11.5	11.1	
16.8		86.2	2202	2.38	44500	PR053090. - M --- 4.0 A	112	11.4	11.0	
14.0		103.2	2638	1.68	44500	PR0530100 - M --- 4.0 A	112	11.3	11.0	
13.2		110.0	2811	1.10	44500	PR0530112 - M --- 4.0 A	112	11.3	10.9	
10.9		133.1	3400	0.91	44500	PR0530140 - M --- 4.0 A	112	11.2	10.8	
15.2		95.3	2435	3.74	52000	PR0830100 - M --- 4.0 A	112	16.4	15.5	
12.7		114.2	2917	2.69	52000	PR0830112 - M --- 4.0 A	112	16.2	15.4	
11.7		123.7	3161	1.71	52000	PR0830125 - M --- 4.0 A	112	16.2	15.3	
9.9		147.2	3760	1.43	52000	PR0830140 - M --- 4.0 A	112	16.1	15.2	
8.3		175.1	4474	1.02	52000	PR0830180 - M --- 4.0 A	112	15.9	15.1	
8.9		162.8	4159	2.19	52000	PR0840180 - M --- 4.0 A	112	13.5	12.8	
7.3		197.3	5042	1.81	52000	PR0840200 - M --- 4.0 A	112	13.4	12.7	
6.1		236.3	6040	1.51	52000	PR0840225 - M --- 4.0 A	112	13.3	12.6	
5.6		259.5	6631	1.37	52000	PR0840250 - M --- 4.0 A	112	13.3	12.6	
5.1		283.1	7235	1.08	52000	PR0840280 - M --- 4.0 A	112	13.3	12.5	
4.6		313.9	8021	1.14	52000	PR0840315 - M --- 4.0 A	112	13.2	12.5	
3.9		376.0	9609	0.95	52000	PR0840360 - M --- 4.0 A	112	13.1	12.4	
3.6		400.7	10239	0.89	52000	PR0840400 - M --- 4.0 A	112	13.1	12.4	

PR MOTORISED RATINGS

	N2	Ratio <i>i</i>	M2 (NM)	fm	FR2 (N)	Unit Designation	Motor Frame	PT(kW) Type B	PT (kW) Type F	
4.0 kW 4 - Pole	11.5	126.4	3231	4.00	54000	PR1630125 - M --- 4.0 A	112	26.6	19.2	
	9.8	148.4	3793	2.11	54000	PR1630140 - M --- 4.0 A	112	26.4	19.1	
	8.2	176.6	4513	1.77	54000	PR1630180 - M --- 4.0 A	112	26.2	18.9	
	8.4	173.1	4424	3.74	54000	PR1640180 - M --- 4.0 A	112	22.5	16.2	
	6.9	209.9	5363	3.08	54000	PR1640200 - M --- 4.0 A	112	22.4	16.1	
	5.8	251.4	6425	2.57	54000	PR1640250 - M --- 4.0 A	112	22.3	16.0	
	5.3	276.0	7054	2.34	54000	PR1640280 - M --- 4.0 A	112	22.2	16.0	
	4.3	333.9	8533	1.94	54000	PR1640315 - M --- 4.0 A	112	22.1	15.9	
	4.2	344.3	8798	1.47	54000	PR1640360 - M --- 4.0 A	112	22.1	15.9	
	3.6	400.0	10221	1.62	54000	PR1640400 - M --- 4.0 A	112	22.0	15.8	
	3.4	426.2	10892	1.52	54000	PR1640450 - M --- 4.0 A	112	21.9	15.8	
	2.8	515.6	13175	1.26	54000	PR1640500 - M --- 4.0 A	112	21.8	15.7	
	2.7	531.6	13585	0.95	54000	PR1640560 - M --- 4.0 A	112	21.8	15.7	
	2.4	613.4	15675	1.06	54000	PR1640630 - M --- 4.0 A	112	21.7	15.6	
	5.8	248.6	6352	3.68	80000	PR2540250 - M --- 4.0 A	112	-	18.4	
	5.4	269.8	6893	2.56	80000	PR2540280 - M --- 4.0 A	112	-	18.3	
	4.5	320.4	8188	2.85	80000	PR2540315 - M --- 4.0 A	112	-	18.2	
	3.8	381.2	9741	2.40	80000	PR2540360 - M --- 4.0 A	112	-	18.1	
	3.5	416.5	10644	1.66	80000	PR2540400 - M --- 4.0 A	112	-	18.1	
	3.2	456.6	11669	2.00	80000	PR2540450 - M --- 4.0 A	112	-	18.0	
	2.9	494.7	12643	1.85	80000	PR2540500 - M --- 4.0 A	112	-	18.0	
	2.5	588.6	15042	1.55	80000	PR2540560 - M --- 4.0 A	112	-	17.9	
	2.3	643.2	16436	1.07	80000	PR2540630 - M --- 4.0 A	112	-	17.9	
	2.1	700.3	17896	1.30	80000	PR2540710 - M --- 4.0 A	112	-	17.8	
	1.9	765.2	19554	0.90	80000	PR2540800 - M --- 4.0 A	112	-	17.8	
	3.6	401.2	10253	3.76	110000	PR4040400 - M --- 4.0 A	112	-	22.2	
	3.3	443.6	11336	3.40	110000	PR4040450 - M --- 4.0 A	112	-	22.2	
	2.8	508.9	13004	2.20	110000	PR4040500 - M --- 4.0 A	112	-	22.1	
	2.6	562.7	14378	1.99	110000	PR4040560 - M --- 4.0 A	112	-	22.1	
	2.3	619.5	15831	2.43	110000	PR4040630 - M --- 4.0 A	112	-	21.9	
	2.0	737.1	18835	2.04	110000	PR4040710 - M --- 4.0 A	112	-	21.9	
	1.8	785.8	20080	1.42	110000	PR4040800 - M --- 4.0 A	112	-	21.8	
	1.6	934.9	23890	1.20	110000	PR4040900 - M --- 4.0 A	112	-	21.8	
	1.3	1097.4	28042	0.86	110000	PR404011C - M --- 4.0 A	112	-	21.7	
	5.5 kW 4 - Pole	118.2	12.3	431	2.58	6191	PR012012. - M --- 5.5 A	132	9.5	8.8
		97.5	14.9	522	1.72	7504	PR012014. - M --- 5.5 A	132	9.3	8.6
		74.2	19.6	687	0.92	9869	PR012018. - M --- 5.5 A	132	9.1	8.4
		118.2	12.3	431	3.70	6191	PR022012. - M --- 5.5 A	132	9.7	9.0
		97.5	14.9	522	3.18	7504	PR022014. - M --- 5.5 A	132	9.5	8.9
		74.2	19.6	687	1.69	9869	PR022018. - M --- 5.5 A	132	9.3	8.6
		61.3	23.7	831	1.03	11939	PR022022. - M --- 5.5 A	132	9.1	8.5
		30.4	47.7	1659	1.24	15000	PR023045. - M --- 5.5 A	132	8.5	7.9
		25.1	57.8	2011	1.02	15000	PR023056. - M --- 5.5 A	132	8.4	7.9
		101.8	14.2	500	6.80	21938	PR032014. - M --- 5.5 A	132	15.4	14.9
		85.0	17.1	599	4.82	26279	PR032018. - M --- 5.5 A	132	15.1	14.7
		65.9	22.0	773	2.60	33875	PR032022. - M --- 5.5 A	132	14.8	14.3
		55.4	26.2	919	1.63	40302	PR032025. - M --- 5.5 A	132	14.5	14.1
		32.5	44.7	1570	2.17	44500	PR033045. - M --- 5.5 A	132	11.3	10.9
26.8		54.2	1903	1.79	44500	PR033056. - M --- 5.5 A	132	11.2	10.8	
22.3		64.9	2280	1.27	44500	PR033063. - M --- 5.5 A	132	11.1	10.7	
20.4		71.2	2503	1.36	44500	PR033071. - M --- 5.5 A	132	11.0	10.7	
16.8		86.2	3028	1.12	44500	PR033090. - M --- 5.5 A	132	10.9	10.6	
14.0		103.2	3627	0.80	44500	PR0330100 - M --- 5.5 A	132	10.9	10.5	
65.9		22.0	773	4.00	33875	PR052022. - M --- 5.5 A	132	15.1	14.7	
55.4		26.2	919	2.50	40302	PR052025. - M --- 5.5 A	132	14.9	14.4	
32.5		44.7	1570	3.33	44500	PR053045. - M --- 5.5 A	132	11.7	11.4	
26.8		54.2	1903	2.75	44500	PR053056. - M --- 5.5 A	132	11.6	11.3	
22.3		64.9	2280	1.95	44500	PR053063. - M --- 5.5 A	132	11.5	11.2	
20.4		71.2	2503	2.09	44500	PR053071. - M --- 5.5 A	132	11.5	11.1	
16.8		86.2	3028	1.73	44500	PR053090. - M --- 5.5 A	132	11.4	11.0	
14.0		103.2	3627	1.22	44500	PR0530100 - M --- 5.5 A	132	11.3	11.0	
13.2		110.0	3865	0.80	44500	PR0530112 - M --- 5.5 A	132	11.3	10.9	
19.5		74.4	2615	3.00	52000	PR083071. - M --- 5.5 A	132	16.5	15.7	
18.1		80.1	2815	3.24	52000	PR083080. - M --- 5.5 A	132	16.5	15.6	
15.2		95.3	3349	2.72	52000	PR0830100 - M --- 5.5 A	132	16.4	15.5	
12.7		114.2	4011	1.95	52000	PR0830112 - M --- 5.5 A	132	16.2	15.4	
11.7		123.7	4346	1.24	52000	PR0830125 - M --- 5.5 A	132	16.2	15.3	
9.9		147.2	5171	1.04	52000	PR0830140 - M --- 5.5 A	132	16.1	15.2	
8.3		175.1	6152	0.74	52000	PR0830180 - M --- 5.5 A	132	15.9	15.1	
8.9		162.8	5719	1.59	52000	PR0840180 - M --- 5.5 A	132	13.5	12.8	
7.3		197.3	6933	1.31	52000	PR0840200 - M --- 5.5 A	132	13.4	12.7	
6.1		236.3	8305	1.10	52000	PR0840225 - M --- 5.5 A	132	13.3	12.6	
5.6		259.5	9118	1.00	52000	PR0840250 - M --- 5.5 A	132	13.3	12.6	
5.1		283.1	9948	0.79	52000	PR0840280 - M --- 5.5 A	132	13.3	12.5	
4.6		313.9	11030	0.83	52000	PR0840315 - M --- 5.5 A	132	13.2	12.5	

SERIES P

PR MOTORISED RATINGS

	N2	Ratio <i>i</i>	M2 (NM)	fm	FR2 (N)	Unit Designation	Motor Frame	PT(kW) Type B	PT (kW) Type F
5.5 kW 4 - Pole	19.5	74.4	2615	3.82	52000	PR123071. -M --- 5.5 A	132	17.2	16.3
	18.1	80.1	2815	4.01	52000	PR123080. -M --- 5.5 A	132	17.1	16.3
	15.2	95.3	3349	3.37	52000	PR1230100 -M --- 5.5 A	132	17.0	16.1
	12.7	114.2	4011	2.49	52000	PR1230112 -M --- 5.5 A	132	16.9	16.0
	11.7	123.7	4346	1.66	52000	PR1230125 -M --- 5.5 A	132	16.8	16.0
	9.9	147.2	5171	1.39	52000	PR1230140 -M --- 5.5 A	132	16.7	15.8
	8.3	175.1	6152	0.99	52000	PR1230180 -M --- 5.5 A	132	16.6	15.7
	8.9	162.8	5719	1.97	52000	PR1240180 -M --- 5.5 A	132	14.2	13.4
	7.3	197.3	6933	1.63	52000	PR1240200 -M --- 5.5 A	132	14.1	13.4
	6.1	236.3	8305	1.36	52000	PR1240225 -M --- 5.5 A	132	14.0	13.3
5.6	259.5	9118	1.24	52000	PR1240250 -M --- 5.5 A	132	14.0	13.2	
5.1	283.1	9948	1.00	52000	PR1240280 -M --- 5.5 A	132	13.9	13.2	
4.6	313.9	11030	1.02	52000	PR1240315 -M --- 5.5 A	132	13.9	13.2	
3.9	376.0	13212	0.85	52000	PR1240360 -M --- 5.5 A	132	13.8	13.1	
3.6	400.7	14079	0.80	52000	PR1240400 -M --- 5.5 A	132	13.8	13.1	
13.6	106.3	3734	3.46	54000	PR1630112 -M --- 5.5 A	132	26.8	19.4	
11.5	126.4	4443	2.91	54000	PR1630125 -M --- 5.5 A	132	26.6	19.2	
9.8	148.4	5215	1.53	54000	PR1630140 -M --- 5.5 A	132	26.4	19.1	
8.2	176.6	6205	1.29	54000	PR1630180 -M --- 5.5 A	132	26.2	18.9	
8.4	173.1	6083	2.72	54000	PR1640180 -M --- 5.5 A	132	22.5	16.2	
6.9	209.9	7375	2.24	54000	PR1640200 -M --- 5.5 A	132	22.4	16.1	
5.8	251.4	8834	1.87	54000	PR1640250 -M --- 5.5 A	132	22.3	16.0	
5.3	276.0	9699	1.71	54000	PR1640280 -M --- 5.5 A	132	22.2	16.0	
4.3	333.9	11732	1.41	54000	PR1640315 -M --- 5.5 A	132	22.1	15.9	
4.2	344.3	12097	1.07	54000	PR1640360 -M --- 5.5 A	132	22.1	15.9	
3.6	400.0	14054	1.18	54000	PR1640400 -M --- 5.5 A	132	22.0	15.8	
3.4	426.2	14976	1.10	54000	PR1640450 -M --- 5.5 A	132	21.9	15.8	
2.8	515.6	18116	0.91	54000	PR1640500 -M --- 5.5 A	132	21.8	15.7	
12.7	114.3	4018	4.39	80000	PR2530112 -M --- 5.5 A	132	-	23.1	
10.7	136.0	4780	3.69	80000	PR2530140 -M --- 5.5 A	132	-	23.0	
8.9	163.5	5745	2.32	80000	PR2530160 -M --- 5.5 A	132	-	22.8	
7.0	207.5	7291	3.20	80000	PR2540200 -M --- 5.5 A	132	-	18.5	
5.8	248.6	8734	2.67	80000	PR2540250 -M --- 5.5 A	132	-	18.4	
5.4	269.8	9478	1.86	80000	PR2540280 -M --- 5.5 A	132	-	18.3	
4.5	320.4	11258	2.07	80000	PR2540315 -M --- 5.5 A	132	-	18.2	
3.8	381.2	13394	1.74	80000	PR2540360 -M --- 5.5 A	132	-	18.1	
3.5	416.5	14636	1.21	80000	PR2540400 -M --- 5.5 A	132	-	18.1	
3.2	456.6	16045	1.46	80000	PR2540450 -M --- 5.5 A	132	-	18.0	
2.9	494.7	17384	1.34	80000	PR2540500 -M --- 5.5 A	132	-	18.0	
2.5	588.6	20683	1.13	80000	PR2540560 -M --- 5.5 A	132	-	17.9	
2.3	643.2	22599	0.78	80000	PR2540630 -M --- 5.5 A	132	-	17.9	
2.1	700.3	24607	0.95	80000	PR2540710 -M --- 5.5 A	132	-	17.8	
5.3	275.9	9694	3.97	110000	PR4040280 -M --- 5.5 A	132	-	22.5	
5.0	292.1	10265	2.78	110000	PR4040315 -M --- 5.5 A	132	-	22.5	
4.1	355.6	12496	3.08	110000	PR4040360 -M --- 5.5 A	132	-	22.3	
3.6	401.2	14097	2.73	110000	PR4040400 -M --- 5.5 A	132	-	22.2	
3.3	443.6	15587	2.47	110000	PR4040450 -M --- 5.5 A	132	-	22.2	
2.8	508.9	17881	1.60	110000	PR4040500 -M --- 5.5 A	132	-	22.1	
2.6	562.7	19770	1.44	110000	PR4040560 -M --- 5.5 A	132	-	22.1	
2.3	619.5	21768	1.77	110000	PR4040630 -M --- 5.5 A	132	-	21.9	
2.0	737.1	25898	1.49	110000	PR4040710 -M --- 5.5 A	132	-	21.9	
1.8	785.8	27610	1.03	110000	PR4040800 -M --- 5.5 A	132	-	21.8	
1.6	934.9	32849	0.87	110000	PR4040900 -M --- 5.5 A	132	-	21.8	
1.3	1097.4	38558	0.62	110000	PR404011C -M --- 5.5 A	132	-	21.7	
2.4	612.3	21735	3.03	240000	PR6540630 -M --- 5.5 A	132	-	28.5	
2.0	741.8	26334	1.97	240000	PR6540710 -M --- 5.5 A	132	-	28.4	
7.5 kW 4 - Pole	118.2	12.3	588	1.89	6191	PR012012. -M --- 7.5 A	132	9.5	8.8
	97.5	14.9	712	1.26	7504	PR012014. -M --- 7.5 A	132	9.3	8.6
	118.2	12.3	588	2.71	6191	PR022012. -M --- 7.5 A	132	9.7	9.0
	61.3	23.7	1133	1.47	11939	PR022014. -M --- 7.5 A	132	8.9	8.3
	30.4	47.7	2285	0.51	15000	PR022018. -M --- 7.5 A	132	8.0	7.5
	25.1	57.8	2770	0.31	15000	PR022022. -M --- 7.5 A	132	7.9	7.4
	30.4	47.7	2262	0.91	15000	PR023045. -M --- 7.5 A	132	8.5	7.9
	101.8	14.2	682	4.98	21938	PR032014. -M --- 7.5 A	132	15.4	14.9
	85.0	17.1	817	3.53	26279	PR032018. -M --- 7.5 A	132	15.1	14.7
	65.9	22.0	1054	1.91	33875	PR032022. -M --- 7.5 A	132	14.8	14.3
	55.4	26.2	1253	1.19	40302	PR032025. -M --- 7.5 A	132	14.5	14.1
	32.5	44.7	2141	1.59	44500	PR033045. -M --- 7.5 A	132	11.3	10.9
	26.8	54.2	2595	1.31	44500	PR033056. -M --- 7.5 A	132	11.2	10.8
	22.3	64.9	3109	0.93	44500	PR033063. -M --- 7.5 A	132	11.1	10.7
	20.4	71.2	3413	1.00	44500	PR033071. -M --- 7.5 A	132	11.0	10.7
	16.8	86.2	4129	0.82	44500	PR033090. -M --- 7.5 A	132	10.9	10.6

PR MOTORISED RATINGS

	N2	Ratio <i>i</i>	M2 (NM)	fm	FR2 (N)	Unit Designation	Motor Frame	PT(kW) Type B	PT (kW) Type F
7.5 kW 4 - Pole	101.8	14.2	682	5.76	21938	PR052014. -M --- 7.5 A	132	15.8	15.3
	85.0	17.1	817	5.43	26279	PR052018. -M --- 7.5 A	132	15.5	15.0
	65.9	22.0	1054	2.93	33875	PR052022. -M --- 7.5 A	132	15.1	14.7
	55.4	26.2	1253	1.83	40302	PR052025. -M --- 7.5 A	132	14.9	14.4
	32.5	44.7	2141	2.44	44500	PR053045. -M --- 7.5 A	132	11.7	11.4
	26.8	54.2	2595	2.02	44500	PR053056. -M --- 7.5 A	132	11.6	11.3
	22.3	64.9	3109	1.43	44500	PR053063. -M --- 7.5 A	132	11.5	11.2
	20.4	71.2	3413	1.53	44500	PR053071. -M --- 7.5 A	132	11.5	11.1
	16.8	86.2	4129	1.27	44500	PR053090. -M --- 7.5 A	132	11.4	11.0
	14.0	103.2	4946	0.90	44500	PR0530100 -M --- 7.5 A	132	11.3	11.0
	65.9	22.0	1054	5.12	39571	PR082022. -M --- 7.5 A	132	24.7	23.4
	55.4	26.2	1253	3.64	47079	PR082025. -M --- 7.5 A	132	24.2	22.9
	28.0	51.9	2486	3.67	52000	PR083050. -M --- 7.5 A	132	16.8	15.9
	23.3	62.1	2977	3.06	52000	PR083063. -M --- 7.5 A	132	16.7	15.8
	19.5	74.4	3566	2.20	52000	PR083071. -M --- 7.5 A	132	16.5	15.7
	18.1	80.1	3838	2.37	52000	PR083080. -M --- 7.5 A	132	16.5	15.6
	15.2	95.3	4566	2.00	52000	PR0830100 -M --- 7.5 A	132	16.4	15.5
	12.7	114.2	5470	1.43	52000	PR0830112 -M --- 7.5 A	132	16.2	15.4
	11.7	123.7	5926	0.91	52000	PR0830125 -M --- 7.5 A	132	16.2	15.3
	8.9	162.8	7799	1.17	52000	PR0840180 -M --- 7.5 A	132	13.5	12.8
	7.3	197.3	9454	0.96	52000	PR0840200 -M --- 7.5 A	132	13.4	12.7
	6.1	236.3	11324	0.80	52000	PR0840225 -M --- 7.5 A	132	13.3	12.6
	23.3	62.1	2977	3.79	52000	PR1230063. -M --- 7.5 A	132	17.3	16.4
	19.5	74.4	3566	2.80	52000	PR123071. -M --- 7.5 A	132	17.2	16.3
	18.1	80.1	3838	2.94	52000	PR123080. -M --- 7.5 A	132	17.1	16.3
	15.2	95.3	4566	2.47	52000	PR1230100 -M --- 7.5 A	132	17.0	16.1
	12.7	114.2	5470	1.83	52000	PR1230112 -M --- 7.5 A	132	16.9	16.0
	11.7	123.7	5926	1.21	52000	PR1230125 -M --- 7.5 A	132	16.8	16.0
	9.9	147.2	7051	1.02	52000	PR1230140 -M --- 7.5 A	132	16.7	15.8
	8.3	175.1	8389	0.73	52000	PR1230180 -M --- 7.5 A	132	16.6	15.7
	8.9	162.8	7799	1.45	52000	PR1240180 -M --- 7.5 A	132	14.2	13.4
	7.3	197.3	9454	1.19	52000	PR1240200 -M --- 7.5 A	132	14.1	13.4
	6.1	236.3	11324	1.00	52000	PR1240225 -M --- 7.5 A	132	14.0	13.3
	5.6	259.5	12433	0.91	52000	PR1240250 -M --- 7.5 A	132	14.0	13.2
	17.0	85.2	4083	4.05	54000	PR1630080. -M --- 7.5 A	132	27.1	19.5
	14.3	101.4	4857	3.41	54000	PR1630100 -M --- 7.5 A	132	26.9	19.4
	13.6	106.3	5092	2.54	54000	PR1630112 -M --- 7.5 A	132	26.8	19.4
	11.5	126.4	6059	2.13	54000	PR1630125 -M --- 7.5 A	132	26.6	19.2
	9.8	148.4	7112	1.12	54000	PR1630140 -M --- 7.5 A	132	26.4	19.1
	8.2	176.6	8461	0.95	54000	PR1630180 -M --- 7.5 A	132	26.2	18.9
	8.4	173.1	8296	1.99	54000	PR1640180 -M --- 7.5 A	132	22.5	16.2
	6.9	209.9	10056	1.64	54000	PR1640200 -M --- 7.5 A	132	22.4	16.1
	5.8	251.4	12046	1.37	54000	PR1640250 -M --- 7.5 A	132	22.3	16.0
	5.3	276.0	13226	1.25	54000	PR1640280 -M --- 7.5 A	132	22.2	16.0
	4.3	333.9	15999	1.03	54000	PR1640315 -M --- 7.5 A	132	22.1	15.9
	4.2	344.3	16496	0.78	54000	PR1640360 -M --- 7.5 A	132	22.1	15.9
	3.6	400.0	19164	0.86	54000	PR1640400 -M --- 7.5 A	132	22.0	15.8
	3.4	426.2	20422	0.81	54000	PR1640450 -M --- 7.5 A	132	21.9	15.8
	13.9	104.6	5014	4.66	80000	PR2530100 -M --- 7.5 A	132	-	23.2
	12.7	114.3	5479	3.22	80000	PR2530112 -M --- 7.5 A	132	-	23.1
	10.7	136.0	6518	2.71	80000	PR2530140 -M --- 7.5 A	132	-	23.0
	8.9	163.5	7834	1.70	80000	PR2530160 -M --- 7.5 A	132	-	22.8
	7.0	207.5	9942	2.35	80000	PR2540200 -M --- 7.5 A	132	-	18.5
	5.8	248.6	11910	1.96	80000	PR2540250 -M --- 7.5 A	132	-	18.4
	5.4	269.8	12925	1.37	80000	PR2540280 -M --- 7.5 A	132	-	18.3
	4.5	320.4	15352	1.52	80000	PR2540315 -M --- 7.5 A	132	-	18.2
	3.8	381.2	18265	1.28	80000	PR2540360 -M --- 7.5 A	132	-	18.1
	3.5	416.5	19958	0.88	80000	PR2540400 -M --- 7.5 A	132	-	18.1
	3.2	456.6	21879	1.07	80000	PR2540450 -M --- 7.5 A	132	-	18.0
	2.9	494.7	23706	0.99	80000	PR2540500 -M --- 7.5 A	132	-	18.0
	2.5	588.6	28203	0.83	80000	PR2540560 -M --- 7.5 A	132	-	17.9
	12.3	117.4	5626	4.26	110000	PR4030125 -M --- 7.5 A	132	-	27.7
	10.4	139.7	6693	4.27	110000	PR4030140 -M --- 7.5 A	132	-	27.5
	8.8	164.0	7857	3.05	110000	PR4030160 -M --- 7.5 A	132	-	27.3
	6.3	230.3	11036	3.49	110000	PR4040225 -M --- 7.5 A	132	-	22.6
	5.3	275.9	13219	2.91	110000	PR4040280 -M --- 7.5 A	132	-	22.5
	5.0	292.1	13998	2.04	110000	PR4040315 -M --- 7.5 A	132	-	22.5
	4.1	355.6	17040	2.26	110000	PR4040360 -M --- 7.5 A	132	-	22.3
	3.6	401.2	19224	2.00	110000	PR4040400 -M --- 7.5 A	132	-	22.2
	3.3	443.6	21255	1.81	110000	PR4040450 -M --- 7.5 A	132	-	22.2
	2.8	508.9	24383	1.17	110000	PR4040500 -M --- 7.5 A	132	-	22.1
	2.6	562.7	26959	1.06	110000	PR4040560 -M --- 7.5 A	132	-	22.1
	2.3	619.5	29683	1.30	110000	PR4040630 -M --- 7.5 A	132	-	21.9
	2.0	737.1	35316	1.09	110000	PR4040710 -M --- 7.5 A	132	-	21.9

SERIES P

PR MOTORISED RATINGS

	N2	Ratio <i>i</i>	M2 (NM)	fm	FR2 (N)	Unit Designation	Motor Frame	PT(kW) Type B	PT (kW) Type F	
7.5 kW 4 - Pole	3.6	401.2	19422	3.93	240000	PR6540400 - M --- 7.5 A	132	-	28.8	
	3.3	443.6	21474	3.58	240000	PR6540450 - M --- 7.5 A	132	-	28.8	
	3.0	490.9	23762	2.74	240000	PR6540500 - M --- 7.5 A	132	-	28.7	
	2.7	527.8	25548	3.04	240000	PR6540560 - M --- 7.5 A	132	-	28.6	
	2.4	612.3	29638	2.23	240000	PR6540630 - M --- 7.5 A	132	-	28.5	
	2.0	741.8	35910	1.45	240000	PR6540 710 - M --- 7.5 A	132	-	28.4	
11.0 kW 4 - Pole	101.8	14.2	1001	8.11	25627	PR082014. - M --- 11. A	160	25.9	24.6	
	85.0	17.1	1199	6.54	30698	PR082018. - M --- 11. A	160	25.4	24.0	
	65.9	22.0	1545	3.49	39571	PR082022. - M --- 11. A	160	24.7	23.4	
	55.4	26.2	1838	2.48	47079	PR082025. - M --- 11. A	160	24.2	22.9	
	65.9	22.0	1545	4.66	39571	PR122022. - M --- 11. A	160	25.2	23.9	
	55.4	26.2	1838	3.31	47079	PR122025. - M --- 11. A	160	24.7	23.5	
	95.7	15.1	1065	12.10	27260	PR162016. - M --- 11. A	160	48.1	35.7	
	76.7	18.9	1328	9.72	34002	PR162020. - M --- 11. A	160	46.9	34.7	
	55.0	26.4	1854	4.31	47485	PR162025. - M --- 11. A	160	45.1	33.4	
	19.6	74.0	5204	3.39	80000	PR253071. - M --- 11. A	160	-	23.6	
	16.5	88.0	6181	3.78	80000	PR253090. - M --- 11. A	160	-	23.4	
	13.9	104.6	7354	3.18	80000	PR2530100 - M --- 11. A	160	-	23.2	
	12.7	114.3	8035	2.20	80000	PR2530112 - M --- 11. A	160	-	23.1	
	10.7	136.0	9560	1.85	80000	PR2530140 - M --- 11. A	160	-	23.0	
	8.9	163.5	11490	1.16	80000	PR2530160 - M --- 11. A	160	-	22.8	
	14.5	100.0	7029	4.06	110000	PR4030100 - M --- 11. A	160	-	28.0	
	13.2	110.1	7740	4.98	110000	PR4030112 - M --- 11. A	160	-	27.8	
	12.3	117.4	8251	2.91	110000	PR4030125 - M --- 11. A	160	-	27.7	
	10.4	139.7	9817	2.91	110000	PR4030140 - M --- 11. A	160	-	27.5	
	8.8	164.0	11523	2.08	110000	PR4030160 - M --- 11. A	160	-	27.3	
	6.3	230.3	16353	4.01	240000	PR6540225 - M --- 11. A	160	-	29.4	
	5.3	275.9	19588	3.54	240000	PR6540280 - M --- 11. A	160	-	29.2	
	4.5	320.1	22724	2.79	240000	PR6540315 - M --- 11. A	160	-	29.1	
	4.1	355.6	25250	2.96	240000	PR6540360 - M --- 11. A	160	-	29.0	
	3.6	401.2	28485	2.68	240000	PR6540400 - M --- 11. A	160	-	28.8	
	3.3	443.6	31495	2.44	240000	PR6540450 - M --- 11. A	160	-	28.8	
	3.0	490.9	34851	1.87	240000	PR6540500 - M --- 11. A	160	-	28.7	
	2.7	527.8	37471	2.07	240000	PR6540560 - M --- 11. A	160	-	28.6	
	2.4	612.3	43470	1.52	240000	PR6540630 - M --- 11. A	160	-	28.5	
	2.0	741.8	52668	0.99	240000	PR6540710 - M --- 11. A	160	-	28.4	
	15.0 kW 4 - Pole	101.8	14.2	1365	5.95	25627	PR082014. - M --- 15. A	160	25.9	24.6
		85.0	17.1	1635	4.80	30698	PR082018. - M --- 15. A	160	25.4	24.0
		65.9	22.0	2107	2.56	39571	PR082022. - M --- 15. A	160	24.7	23.4
		55.4	26.2	2507	1.82	47079	PR082025. - M --- 15. A	160	24.2	22.9
		85.0	17.1	1635	5.95	30698	PR122018. - M --- 15. A	160	26.0	24.6
		65.9	22.0	2107	3.42	39571	PR122022. - M --- 15. A	160	25.2	23.9
55.4		26.2	2507	2.43	47079	PR122025. - M --- 15. A	160	24.7	23.5	
95.7		15.1	1452	8.87	27260	PR162016. - M --- 15. A	160	48.1	35.7	
76.7		18.9	1811	7.13	34002	PR162020. - M --- 15. A	160	46.9	34.7	
55.0		26.4	2529	3.16	47485	PR162025. - M --- 15. A	160	45.1	33.4	
25.5		57.0	5459	4.28	80000	PR253056. - M --- 15. A	160	-	23.9	
21.3		68.2	6539	3.57	80000	PR253063. - M --- 15. A	160	-	23.7	
19.6		74.0	7096	2.49	80000	PR253071. - M --- 15. A	160	-	23.6	
16.5		88.0	8429	2.77	80000	PR253090. - M --- 15. A	160	-	23.4	
13.9		104.6	10028	2.33	80000	PR2530100 - M --- 15. A	160	-	23.2	
12.7		114.3	10957	1.61	80000	PR2530112 - M --- 15. A	160	-	23.1	
10.7		136.0	13036	1.35	80000	PR2530140 - M --- 15. A	160	-	23.0	
8.9		163.5	15669	0.85	80000	PR2530160 - M --- 15. A	160	-	22.8	
18.1		80.2	7685	3.72	110000	PR403080. - M --- 15. A	160	-	28.2	
14.5		100.0	9585	2.98	110000	PR4030100 - M --- 15. A	160	-	28.0	
13.2		110.1	10554	3.65	110000	PR4030112 - M --- 15. A	160	-	27.8	
12.3		117.4	11252	2.13	110000	PR4030125 - M --- 15. A	160	-	27.7	
10.4		139.7	13387	2.13	110000	PR4030140 - M --- 15. A	160	-	27.5	
8.8		164.0	15713	1.53	110000	PR4030160 - M --- 15. A	160	-	27.3	
6.3		230.3	22299	2.94	240000	PR6540225 - M --- 15. A	160	-	29.4	
5.3		275.9	26711	2.59	240000	PR6540280 - M --- 15. A	160	-	29.2	
4.5		320.1	30987	2.04	240000	PR6540315 - M --- 15. A	160	-	29.1	
4.1		355.6	34432	2.17	240000	PR6540360 - M --- 15. A	160	-	29.0	
3.6		401.2	38843	1.97	240000	PR6540400 - M --- 15. A	160	-	28.8	
3.3		443.6	42948	1.79	240000	PR6540450 - M --- 15. A	160	-	28.8	
3.0		490.9	47524	1.37	240000	PR6540500 - M --- 15. A	160	-	28.7	
2.7		527.8	51097	1.52	240000	PR6540560 - M --- 15. A	160	-	28.6	
2.4		612.3	59277	1.11	240000	PR6540630 - M --- 15. A	160	-	28.5	

PR MOTORISED RATINGS

	N2	Ratio <i>i</i>	M2 (NM)	fm	FR2 (N)	Unit Designation	Motor Frame	PT(kW) Type B	PT (kW) Type F	
18.5 kW 4 - Pole	101.8	14.2	1683	4.82	25627	PR082014. - M --- 18. A	180	25.9	24.6	
	85.0	17.1	2016	3.89	30698	PR082018. - M --- 18. A	180	25.4	24.0	
	65.9	22.0	2599	2.08	39571	PR082022. - M --- 18. A	180	24.7	23.4	
	55.4	26.2	3092	1.48	47079	PR082025. - M --- 18. A	180	24.2	22.9	
	85.0	17.1	2016	4.82	30698	PR122018. - M --- 18. A	180	26.0	24.6	
	65.9	22.0	2599	2.77	39571	PR122022. - M --- 18. A	180	25.2	23.9	
	55.4	26.2	3092	1.97	47079	PR122025. - M --- 18. A	180	24.7	23.5	
	95.7	15.1	1790	7.19	27260	PR162016. - M --- 18. A	180	48.1	35.7	
	76.7	18.9	2233	5.78	34002	PR162020. - M --- 18. A	180	46.9	34.7	
	55.0	26.4	3119	2.56	47485	PR162025. - M --- 18. A	180	45.1	33.4	
	25.5	57.0	6732	3.47	80000	PR253056. - M --- 18. A	180	-	23.9	
	21.3	68.2	8064	2.90	80000	PR253063. - M --- 18. A	180	-	23.7	
	19.6	74.0	8752	2.02	80000	PR253071. - M --- 18. A	180	-	23.6	
	16.5	88.0	10395	2.25	80000	PR253090. - M --- 18. A	180	-	23.4	
	13.9	104.6	12368	1.89	80000	PR2530100 - M --- 18. A	180	-	23.2	
	12.7	114.3	13514	1.31	80000	PR2530112 - M --- 18. A	180	-	23.1	
	10.7	136.0	16078	1.10	80000	PR2530140 - M --- 18. A	180	-	23.0	
	22.9	63.2	7473	5.15	110000	PR403063. - M --- 18. A	180	-	28.5	
	18.4	78.9	9321	4.13	110000	PR403071. - M --- 18. A	180	-	28.3	
	18.1	80.2	9478	3.01	110000	PR403080. - M --- 18. A	180	-	28.2	
	14.5	100.0	11822	2.42	110000	PR4030100 - M --- 18. A	180	-	28.0	
	13.2	110.1	13017	2.96	110000	PR4030112 - M --- 18. A	180	-	27.8	
	12.3	117.4	13877	1.73	110000	PR4030125 - M --- 18. A	180	-	27.7	
	10.4	139.7	16510	1.73	110000	PR4030140 - M --- 18. A	180	-	27.5	
	8.8	164.0	19380	1.24	110000	PR4030160 - M --- 18. A	180	-	27.3	
	6.3	230.3	27501	2.39	240000	PR6540225 - M --- 18. A	180	-	29.4	
	5.3	275.9	32942	2.10	240000	PR6540280 - M --- 18. A	180	-	29.2	
	4.5	320.1	38216	1.66	240000	PR6540315 - M --- 18. A	180	-	29.1	
	4.1	355.6	42464	1.76	240000	PR6540360 - M --- 18. A	180	-	29.0	
	3.6	401.2	47904	1.59	240000	PR6540400 - M --- 18. A	180	-	28.8	
	3.3	443.6	52966	1.45	240000	PR6540450 - M --- 18. A	180	-	28.8	
	3.0	490.9	58609	1.11	240000	PR6540500 - M --- 18. A	180	-	28.7	
	2.7	527.8	63016	1.23	240000	PR6540560 - M --- 18. A	180	-	28.6	
	2.4	612.3	73104	0.90	240000	PR6540630 - M --- 18. A	180	-	28.5	
	22.0 kW 4 - Pole	101.8	14.2	2001	4.06	25627	PR082014. - M --- 22. A	180	25.9	24.6
		85.0	17.1	2397	3.27	30698	PR082018. - M --- 22. A	180	25.4	24.0
		65.9	22.0	3090	1.75	39571	PR082022. - M --- 22. A	180	24.7	23.4
		55.4	26.2	3677	1.24	47079	PR082025. - M --- 22. A	180	24.2	22.9
		85.0	17.1	2397	4.06	30698	PR122018. - M --- 22. A	180	26.0	24.6
		65.9	22.0	3090	2.33	39571	PR122022. - M --- 22. A	180	25.2	23.9
		55.4	26.2	3677	1.65	47079	PR122025. - M --- 22. A	180	24.7	23.5
		95.7	15.1	2129	6.05	27260	PR162016. - M --- 22. A	180	48.1	35.7
		76.7	18.9	2656	4.86	34002	PR162020. - M --- 22. A	180	46.9	34.7
		55.0	26.4	3709	2.16	47485	PR162025. - M --- 22. A	180	45.1	33.4
		25.5	57.0	8006	2.92	80000	PR253056. - M --- 22. A	180	-	23.9
		21.3	68.2	9590	2.43	80000	PR253063. - M --- 22. A	180	-	23.7
		19.6	74.0	10408	1.70	80000	PR253071. - M --- 22. A	180	-	23.6
		16.5	88.0	12362	1.89	80000	PR253090. - M --- 22. A	180	-	23.4
13.9		104.6	14708	1.59	80000	PR2530100 - M --- 22. A	180	-	23.2	
12.7		114.3	16071	1.10	80000	PR2530112 - M --- 22. A	180	-	23.1	
10.7		136.0	19120	0.92	80000	PR2530140 - M --- 22. A	180	-	23.0	
8.9		163.5	22981	0.58	80000	PR2530160 - M --- 22. A	180	-	22.8	
22.9		63.2	8886	4.33	110000	PR403063. - M --- 22. A	180	-	28.5	
18.4		78.9	11084	3.47	110000	PR403071. - M --- 22. A	180	-	28.3	
18.1		80.2	11271	2.53	110000	PR403080. - M --- 22. A	180	-	28.2	
14.5		100.0	14059	2.03	110000	PR4030100 - M --- 22. A	180	-	28.0	
13.2		110.1	15479	2.49	110000	PR4030112 - M --- 22. A	180	-	27.8	
12.3		117.4	16502	1.45	110000	PR4030125 - M --- 22. A	180	-	27.7	
10.4		139.7	19634	1.45	110000	PR4030140 - M --- 22. A	180	-	27.5	
8.8		164.0	23046	1.04	110000	PR4030160 - M --- 22. A	180	-	27.3	
6.3		230.3	32705	2.01	240000	PR6540225 - M --- 22. A	180	-	29.4	
5.3		275.9	39176	1.77	240000	PR6540280 - M --- 22. A	180	-	29.2	
4.5		320.1	45448	1.39	240000	PR6540315 - M --- 22. A	180	-	29.1	
4.1		355.6	50501	1.48	240000	PR6540360 - M --- 22. A	180	-	29.0	
3.6		401.2	56970	1.34	240000	PR6540400 - M --- 22. A	180	-	28.8	
3.3		443.6	62990	1.22	240000	PR6540450 - M --- 22. A	180	-	28.8	
3.0		490.9	69701	0.93	240000	PR6540500 - M --- 22. A	180	-	28.7	
2.7		527.8	74942	1.04	240000	PR6540560 - M --- 22. A	180	-	28.6	
2.4		612.3	86939	0.76	240000	PR6540630 - M --- 22. A	180	-	28.5	

SERIES P

LUBRICATION

Lubrication

1. Check that the ventilator is positioned correctly for the intended mounting position.
2. Gear units are supplied without lubricant and must be filled via the ventilator position with the appropriate lubricant until oil escapes through the level plug hole.
 - Please refer to the lubricant quantity table for approximate lubricant quantity
 - Refer to the unit nameplate for the type and grade of lubricant.
 - Refer the table of approved lubricants.
3. Maintenance: Oil levels should be checked and maintained by filling via the ventilator position until oil escapes through the level plug hole.

Mounting Positions and Lubrication Fill Levels

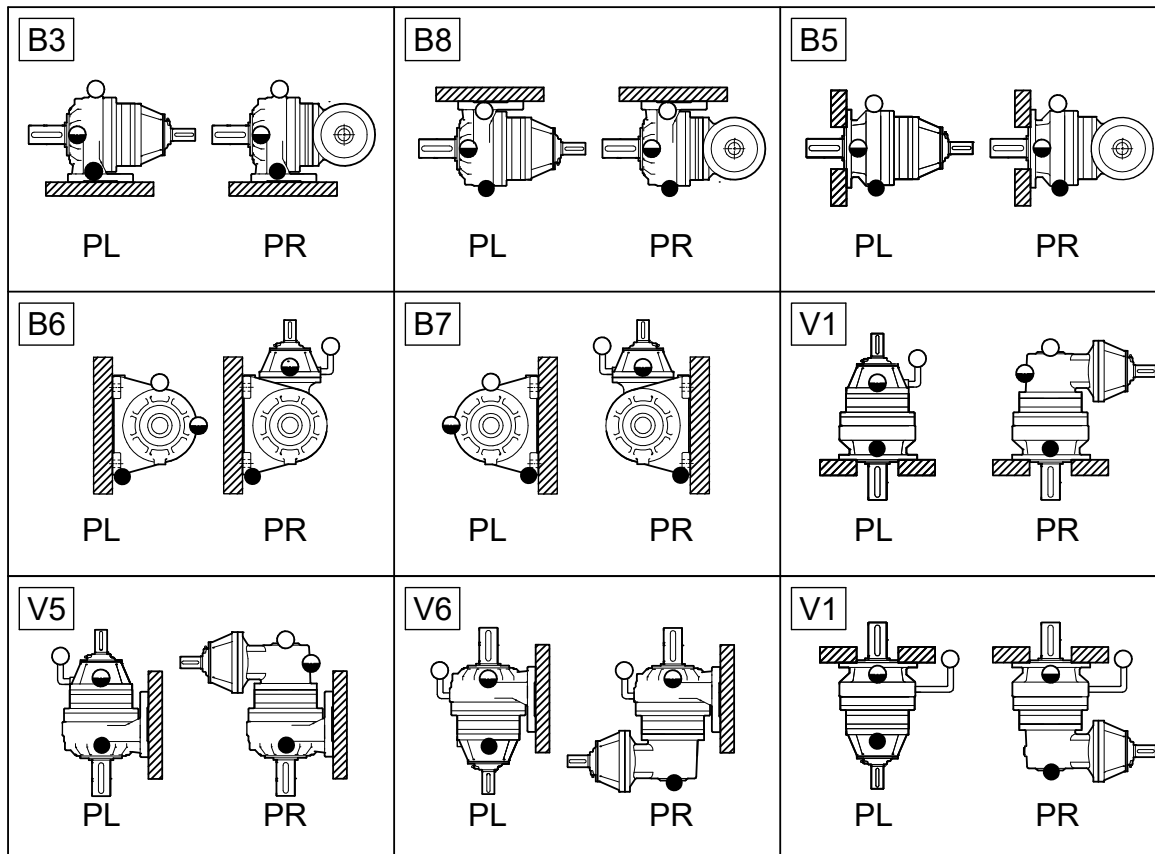

● Oil Level Position

● Drain Position

○ Ventilator / Filling

SERIES P

LUBRICATION

Lubricants Quantities (Litres) PL UNITS

	PL0110	PL0120	PL0130	PL0140	PL0210	PL0220	PL0230	PL0240	PL0310	PL0320	PL0330	PL0340	PL0510	PL0520
B3	1.4	1.6	1.8	2.0	1.4	1.6	1.8	2.0	3.6	3.5	3.7	3.9	3.6	3.5
B5	0.8	1.0	1.2	1.4	0.8	1.0	1.2	1.4	2.0	1.9	2.1	2.3	2.0	1.9
B6	1.2	1.4	1.6	1.8	1.2	1.4	1.6	1.8	2.9	2.8	3.0	3.2	2.9	2.8
B7	1.2	1.4	1.6	1.8	1.2	1.4	1.6	1.8	2.9	2.8	3.0	3.2	2.9	2.8
B8	0.9	1.1	1.3	1.5	0.9	1.1	1.3	1.5	2.2	2.0	2.2	2.4	2.1	2.0
V1	1.6	2.0	2.4	2.8	1.6	2.0	2.4	2.8	4.1	3.8	4.2	4.6	4.0	3.8
V3	1.6	2.0	2.4	2.8	1.6	2.0	2.4	2.8	4.1	3.8	4.2	4.6	4.0	3.8
V5	2.4	2.8	3.2	3.6	2.4	2.8	3.2	3.6	5.9	5.7	6.0	6.4	5.9	5.6
V6	2.4	2.8	3.2	3.6	2.4	2.8	3.2	3.6	5.9	5.7	6.0	6.4	5.9	5.6

	PL0530	PL0540	PL0810	PL0820	PL0830	PL0840	PL1210	PL1220	PL1230	PL1240	PL1610	PL1620	PL1630	PL1640
B3	3.7	3.9	6.7	6.9	6.8	7.0	6.7	7.0	6.9	7.1	9.87	9.88	9.81	9.95
B5	2.1	2.3	3.3	3.6	3.5	3.7	3.4	3.6	3.5	3.7	4.98	4.99	4.92	5.05
B6	3.0	3.2	5.3	5.6	5.5	5.7	5.4	5.6	5.5	5.7	8.13	8.14	8.07	8.20
B7	3.0	3.2	5.3	5.6	5.5	5.7	5.4	5.6	5.5	5.7	8.13	8.14	8.07	8.20
B8	2.2	2.4	3.7	3.9	3.8	4.0	3.7	4.0	3.9	4.1	6.38	6.39	6.32	6.46
V1	4.2	4.6	6.6	7.2	7.0	7.4	6.7	7.2	7.0	7.4	9.95	9.96	9.83	10.11
V3	4.2	4.6	6.6	7.2	7.0	7.4	6.7	7.2	7.0	7.4	9.95	9.96	9.83	10.11
V5	6.0	6.4	10.7	11.2	11.0	11.4	10.8	11.3	11.1	11.5	16.25	16.26	16.13	16.41
V6	6.0	6.4	10.7	11.2	11.0	11.4	10.8	11.3	11.1	11.5	16.25	16.26	16.13	16.41

	PL2510	PL2520	PL2530	PL2540	PL4010	PL4020	PL4030	PL4040	PL6510	PL6520	PL6530	PL6540
B3	4.31	4.37	4.53	4.54	6.85	6.88	6.95	6.96	10.52	10.55	11.03	11.17
B5	4.31	4.37	4.53	4.54	6.85	6.88	6.95	6.96	10.52	10.55	11.03	11.17
B6	4.31	4.37	4.53	4.54	6.85	6.88	6.95	6.96	10.52	10.55	11.03	11.17
B7	4.31	4.37	4.53	4.54	6.85	6.88	6.95	6.96	10.52	10.55	11.03	11.17
B8	4.31	4.37	4.53	4.54	6.85	6.88	6.95	6.96	10.52	10.55	11.03	11.17
V1	8.62	8.75	9.05	9.08	13.70	13.76	13.89	13.90	21.05	21.10	22.07	22.34
V3	8.62	8.75	9.05	9.08	13.70	13.76	13.89	13.90	21.05	21.10	22.07	22.34
V5	8.62	8.75	9.05	9.08	13.70	13.76	13.89	13.90	21.05	21.10	22.07	22.34
V6	8.62	8.75	9.05	9.08	13.70	13.76	13.89	13.90	21.05	21.10	22.07	22.34

Lubricants Quantities (Litres) PR UNITS

	PR0120	PR0130	PR0140	PR0220	PR0230	PR0240	PR0320	PR0330	PR0340	PR0520	PR0530	PR0540	PR0820
B3	1.7	1.9	2.1	1.7	1.9	2.1	3.9	3.8	4.0	3.9	3.8	4.0	7.7
B5	1.1	1.3	1.5	1.1	1.3	1.5	2.3	2.2	2.4	2.3	2.2	2.4	4.3
B6	1.5	1.7	1.9	1.5	1.7	1.9	3.2	3.1	3.3	3.2	3.1	3.3	6.3
B7	1.5	1.7	1.9	1.5	1.7	1.9	3.2	3.1	3.3	3.2	3.1	3.3	6.3
B8	1.2	1.4	1.6	1.2	1.4	1.6	2.5	2.3	2.5	2.4	2.3	2.5	4.7
V1	1.9	2.3	2.7	1.9	2.3	2.7	4.4	4.1	4.5	4.3	4.1	4.5	7.6
V3	1.9	2.3	2.7	1.9	2.3	2.7	4.4	4.1	4.5	4.3	4.1	4.5	7.6
V5	2.7	3.1	3.5	2.7	3.1	3.5	6.2	6.0	6.3	6.2	5.9	6.3	11.7
V6	2.7	3.1	3.5	2.7	3.1	3.5	6.2	6.0	6.3	6.2	5.9	6.3	11.7

	PR0830	PR0840	PR1220	PR1230	PR1240	PR1620	PR1630	PR1640	PR2530	PR2540	PR4030	PR4040	PR6540
B3	7.2	7.1	7.7	7.3	7.2	11.6	10.2	10.1	6.07	4.83	8.58	7.25	11.3
B5	3.9	3.8	4.4	3.9	3.8	6.68	5.29	5.22	6.07	4.83	8.58	7.25	11.3
B6	5.9	5.8	6.4	5.9	5.8	9.83	8.44	8.37	6.07	4.83	8.58	7.25	11.3
B7	5.9	5.8	6.4	5.9	5.8	9.83	8.44	8.37	6.07	4.83	8.58	7.25	11.3
B8	4.2	4.1	4.7	4.3	4.2	8.08	6.69	6.62	6.07	4.83	8.58	7.25	11.3
V1	7.5	7.3	7.7	7.5	7.3	11.7	10.3	10.1	10.5	9.35	15.5	14.2	22.4
V3	7.5	7.3	7.7	7.5	7.3	11.7	10.3	10.1	10.5	9.35	15.5	14.2	22.4
V5	11.5	11.3	11.8	11.6	11.4	18.0	16.6	16.4	10.5	9.35	15.5	14.2	22.4
V6	11.5	11.3	11.8	11.6	11.4	18.0	16.6	16.4	10.5	9.35	15.5	14.2	22.4

Approved Lubricants

Approved Lubricants Type E ISO: CLP-CC - Mineral oil's containing industrial EP additives

Supplier	Lubricant Type	4E	5E	6E
		Ambient Temperature Range		
		-5 to 20°C	10 to 40°C	30 to 50°C
BP Oil International Limited	Energol GR-XF	150 (-19)	220 (-16)	320 (-13)
	Energol GR-XP	150 (-19)	220 (-15)	320 (-10)
Caltex	Meropa	150 (-4)	220 (-4)	320 (-4)
Castrol International	Alpha SP	150 (-16)	220 (-16)	320 (-16)
Esso/Exxon	Spartan EP	150 (-19)	220 (-12)	320 (-12)
Fuchs Lubricants	Renolin CLP	150(-17)	220 (-16)	320 (-14)
Klüber Lubrication	Klüberoil GEM1	150 (-5)	220 (-5)	320 (-5)
Kuwait Petroleum International	Q8 Goya	150 (-22)	220 (-16)	320 (-13)
Mobil Oil Company Limited	Mobil gear 600 series	629 (-19)	630 (-13)	632 (-13)
	Mobil gear XMP	150 (-22)	220 (-19)	320 (-13)
Optimal Ölwerke GmbH	Optigear BM	150 (-13)	220 (-11)	320 (-10)
Petro-Canada	Ultima EP	150 (-28)	220 (-22)	320 (-16)
Rocol	Saphire Hi-Torque	150 (-13)	220 (-13)	320 (-13)
Shell Oils	Omala	150 (-4)	220 (-4)	320 (-4)
	Omala F	150 (-16)	220 (-13)	320 (-10)
Texaco Limited	Meropa	150 (-19)	220 (-16)	320 (-16)
	Meropa WM	150 (-19)	220 (-19)	320 (-16)
Total	Carter EP	150 (-7)	220 (-7)	320 (-7)
Tribol	Tribol 1100	150 (-22)	220 (-20)	320 (-18)

Numbers in brackets indicate the minimum pour point temperature of the specified oil (in °C)
The gear unit must not be run below this temperature.

Approved Lubricants Type H

ISO: CLP-HC - Polyalphaolefin based synthetic lubricants with anti-wear or EP additives.

Supplier	Lubricant Type	4H	5H	6H
		Ambient Temperature Range		
		-30 to 20°C	-10 to 40°C	30 to 50°C
BP Oil International Limited	Enersyn EPX	-	-	320 (-28)
Caltex	Pinnacle EP	150 (-45)	220 (-43)	320 (-43)
Carl Bechem GmbH	Ber synth GP	150 (-42)	220 (-38)	320 (-35)
Castrol International	Alphasyn EP	150 (-43)	220 (-37)	320 (-31)
	Alphasyn T	150 (-31)	220 (-31)	320 (-28)
Esso/Exxon	Spartan Synthetic EP	150 (-49)	220 (-46)	320 (-43)
Fuchs Lubricants	Renolin Unisyn CLP	150 (-40)	220 (-37)	320 (-34)
Klüber Lubrication	Klübersynth GEM4	150 (-35)	220 (-30)	320 (-25)
Kuwait Petroleum International	Q8 El Greco	150 (-28)	220 (-22)	320 (-19)
Mobil Oil Company Limited	Mobilgear SHC	150 (-43)	220 (-40)	320 (-37)
Optimal Ölwerke GmbH	Optigear Synthetic A	-	220 (-31)	320 (-31)
Petro-Canada	Super Gear Fluid	150 (-37)	220 (-37)	320 (-37)
Shell Oils	Omala HD	150 (-49)	220 (-43)	320 (-40)
Texaco Limited	Pinnacle EP	150 (-45)	220 (-43)	320 (-43)
Total	Carter EP/HT	150 (-37)	220 (-34)	320 (-31)
Tribol GmbH	Tribol 1510	150 (-41)	220 (-36)	320 (-33)

Numbers in brackets indicate the minimum pour point temperature of the specified oil (in °C)
The gear unit must not be run below this temperature.

Approved Bearing Greases

NLGI grade 2 grease's, suitable for operating in ambient temperature range of -20°C to 50°C

For use outside this range consult our Application Engineers

Supplier	Lubricant Range
BP Oil International Limited	Energrease LS-EP
Caltex	Multifak EP
Castrol International	LXM Grease
Fuchs Lubricants	Renolit EP
Klüber Lubrication	Klüberlub BE 41-542
Mobil Oil Company Limited	Mobilgrease XHP
Omega Manufacturing Division	Omega 85
Optimol Ölwerke GmbH	Longtime PD
Shell Oils	Albida RL
	Alvania EP B
Texaco Limited	Multifak All Purpose EP

SHIPPING SPECIFICATION

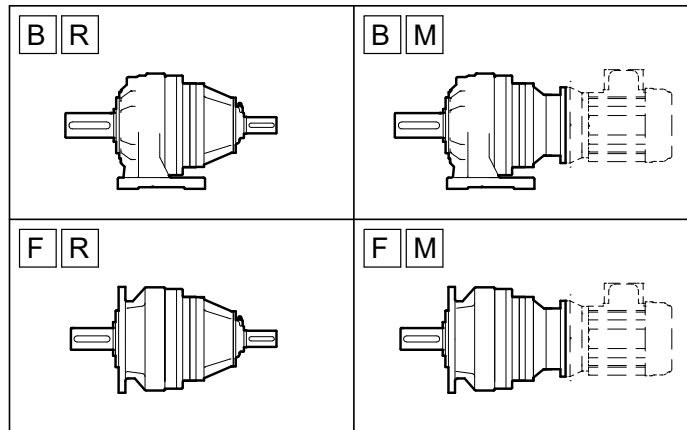

Weight (kg) PL Units

	BR	FR	63		71		80		90		100 / 112		132		160		180		200		225		
			BM	FM	BM	FM	BM	FM	BM	FM	BM	FM	BM	FM	BM	FM	BM	FM	BM	FM	BM	FM	
PL0110	30	27	28	25	28	25	30	27	30	27	31	27	32	29	-	-	-	-	-	-	-	-	
PL0120	36	33	34	31	35	31	36	33	36	33	37	34	38	35	-	-	-	-	-	-	-	-	
PL0130	42	39	40	37	41	38	42	39	42	39	43	40	44	41	-	-	-	-	-	-	-	-	
PL0140	48	45	46	43	47	44	48	45	48	45	49	46	50	47	-	-	-	-	-	-	-	-	
PL0210	32	29	30	27	31	28	32	29	32	29	33	30	34	31	-	-	-	-	-	-	-	-	
PL0220	38	35	36	33	37	34	38	35	38	35	39	36	41	37	-	-	-	-	-	-	-	-	
PL0230	45	42	43	40	43	40	45	42	45	42	46	42	47	44	-	-	-	-	-	-	-	-	
PL0240	51	48	49	46	50	46	51	48	51	48	52	49	53	50	-	-	-	-	-	-	-	-	
PL0310	65	58	59	53	60	54	61	55	61	55	62	56	64	57	67	61	67	61	-	-	-	-	
PL0320	65	59	64	57	64	58	65	59	65	59	66	60	68	61	-	-	-	-	-	-	-	-	
PL0330	72	66	70	64	70	64	72	66	72	66	73	66	74	68	-	-	-	-	-	-	-	-	
PL0340	78	72	76	70	77	70	78	72	78	72	79	73	80	74	-	-	-	-	-	-	-	-	
PL0510	69	63	64	58	65	58	66	60	66	60	67	61	68	62	72	66	71	65	-	-	-	-	
PL0520	74	68	72	66	73	66	74	68	74	68	75	69	76	70	-	-	-	-	-	-	-	-	
PL0530	80	74	78	72	79	73	80	74	80	74	81	75	82	76	-	-	-	-	-	-	-	-	
PL0540	86	80	84	78	85	79	86	80	86	80	87	81	89	82	-	-	-	-	-	-	-	-	
PL0810	111	100	-	-	-	-	109	98	109	98	110	99	111	100	115	104	115	104	117	106	-	-	
PL0820	117	106	112	101	112	101	114	103	114	103	115	104	116	105	119	108	119	108	-	-	-	-	
PL0830	118	107	116	105	116	106	118	107	118	107	119	107	120	109	-	-	-	-	-	-	-	-	
PL0840	124	113	122	111	123	111	124	113	124	113	125	114	126	115	-	-	-	-	-	-	-	-	
PL1210	118	107	-	-	-	-	116	105	116	105	118	106	118	107	123	112	123	111	125	113	-	-	
PL1220	129	118	124	113	125	113	126	115	126	115	127	116	128	117	132	120	131	120	-	-	-	-	
PL1230	134	123	132	121	133	121	134	123	134	123	135	124	136	125	-	-	-	-	-	-	-	-	
PL1240	140	129	138	127	139	127	140	129	140	129	141	130	142	131	-	-	-	-	-	-	-	-	
PL1610	199	175	-	-	-	-	-	-	-	-	-	-	-	-	-	-	-	-	-	189	165	191	168
PL1620	195	171	-	-	-	-	-	-	-	-	-	-	194	170	197	174	197	173	-	-	-	-	
PL1630	199	176	197	174	197	174	199	176	199	176	200	177	201	178	-	-	-	-	-	-	-	-	
PL1640	205	182	203	180	204	181	205	182	205	182	206	183	208	184	-	-	-	-	-	-	-	-	
PL2510	261	222	-	-	-	-	-	-	-	-	-	-	-	-	-	-	-	-	-	240	200	242	203
PL2520	261	222	-	-	-	-	-	-	-	-	-	-	-	-	266	226	265	226	267	228	-	-	
PL2530	267	228	-	-	-	-	-	-	-	-	-	-	266	227	270	231	269	230	-	-	-	-	
PL2540	269	230	267	228	268	229	269	230	269	230	270	231	272	232	-	-	-	-	-	-	-	-	

IMPORTANT

Product Safety Information

General - The following information is important in ensuring safety. It **must** be brought to the attention of personnel involved in the selection of power transmission equipment, those responsible for the design of the machinery in which it is to be incorporated and those involved in its installation, use and maintenance.

Our equipment will operate safely provided it is selected, installed, used and maintained properly. As with any power transmission equipment **proper precautions must be taken** as indicated in the following paragraphs, to ensure safety.

Potential Hazards - these are not necessarily listed in any order of severity as the degree of danger varies in individual circumstances. It is important therefore that the list is studied in its entirety:-

1) Fire/Explosion

(a) Oil mists and vapour are generated within gear units. It is therefore dangerous to use naked lights in the proximity of gearbox openings, due to the risk of fire or explosion.

(b) In the event of fire or serious overheating (over 300 °C), certain materials (rubber, plastics, etc.) may decompose and produce fumes. Care should be taken to avoid exposure to the fumes, and the remains of burned or overheated plastic/rubber materials should be handled with rubber gloves.

2) Guards - Rotating shafts and couplings must be guarded to eliminate the possibility of physical contact or entanglement of clothing. It should be of rigid construction and firmly secured.

3) Noise - High speed gearboxes and gearbox driven machinery may produce noise levels which are damaging to the hearing with prolonged exposure. Ear defenders should be provided for personnel in these circumstances. Reference should be made to the Department of Employment Code of Practice for reducing exposure of employed persons to noise.

4) Lifting - Where provided (on larger units) only the lifting points or eyebolts must be used for lifting operations (see maintenance manual or general arrangement drawing for lifting point positions). Failure to use the lifting points provided may result in personal injury and/or damage to the product or surrounding equipment. Keep clear of raised equipment.

5) Lubricants and Lubrication

(a) Prolonged contact with lubricants can be detrimental to the skin. The manufacturer's instruction must be followed when handling lubricants.

(b) The lubrication status of the equipment must be checked before commissioning. Read and carry out all instructions on the lubricant plate and in the installation and maintenance literature. Heed all warning tags. Failure to do so could result in mechanical damage and in extreme cases risk of injury to personnel.

6) Electrical Equipment - Observe hazard warnings on electrical equipment and isolate power before working on the gearbox or associated equipment, in order to prevent the machinery being started.

7) Installation, Maintenance and Storage

(a) In the event that equipment is to be held in storage, for a period exceeding 6 months, prior to installation or commissioning, we must be consulted regarding special preservation requirements. Unless otherwise agreed, equipment must be stored in a building protected from extremes of temperature and humidity to prevent deterioration.

The rotating components (gears and shafts) must be turned a few revolutions once a month (to prevent bearings brinelling).

(b) External gearbox components may be supplied with preservative materials applied, in the form of a "waxed" tape overwrap or wax film preservative. Gloves should be worn when removing these materials. The former can be removed manually, the latter using white spirit as a solvent.

Preservatives applied to the internal parts of the gear units do not require removal prior to operation.

(c) Installation must be performed in accordance with the manufacturer's instructions and be undertaken by suitably qualified personnel.

(d) Before working on a gearbox or associated equipment, ensure that the load has been removed from the system to eliminate the possibility of any movement of the machinery and isolate power supply. Where necessary, provide mechanical means to ensure the machinery cannot move or rotate. Ensure removal of such devices after work is complete.

(e) Ensure the proper maintenance of gearboxes in operation. Use only the correct tools and our approved spare parts for repair and maintenance. Consult the Maintenance Manual before dismantling or performing maintenance work.

8) Hot Surfaces and Lubricants

(a) During operation, gear units may become sufficiently hot to cause skin burns. Care must be taken to avoid accidental contact.

(b) After extended running the lubricant in gear units and lubrication systems may reach temperatures sufficient to cause burns. Allow equipment to cool before servicing or performing adjustments.

9) Selection and Design

(a) Where gear units provide a backstop facility, ensure that back-up systems are provided if failure of the backstop device would endanger personnel or result in damage.

(b) The driving and driven equipment must be correctly selected to ensure that the complete machinery installation will perform satisfactorily, avoiding system critical speeds, system torsional vibration, etc.

(c) The equipment must not be operated in an environment or at speeds, powers, torques or with external loads beyond those for which it was designed.

(d) As improvements in design are being made continually the contents of this catalogue are not to be regarded as binding in detail, and drawings and capacities are subject to alterations without notice.

The above guidance is based on the current state of knowledge and our best assessment of the potential hazards in the operation of the gear units.

Any further information or clarification required may be obtained by contacting our Application Engineers.

CONTACT US

AUSTRALIA

Radicon Transmission (Australia) PTY Ltd

Australia
Tel: +61 421 822 315

EUROPE

Benzler TBA BV

Jachthavenweg 2
NL-5928 NT Venlo

Germany
Tel: 0800 350 40 00
Fax: 0800 350 40 01

Italy
Tel: +39 02 824 3511

Netherlands & the rest of Europe
Tel: +31 77 324 59 00
Fax: +31 77 324 59 01

DENMARK

Benzler Transmission A/S

Dalager 1
DK-2605 Brøndby,
Denmark

Tel: +45 36 34 03 00
Fax: +45 36 77 02 42

FINLAND

Oy Benzler AB

Vanha Talvitie 3C
FI-00580 Helsingfors,
Finland

Tel: +358 9 340 1716
Fax: +358 10 296 2072

INDIA

Elecon. Engineering Company Ltd.

Anand Sojitra Road
Vallabh Vidyanagar
388120 Gujarat
India

Tel: +91 2692 236513
Fax: +91 2692 227484

SWEDEN & NORWAY

AB Benzlers

Porfyrgatan
254 68 Helsingborg
Sweden

Tel: +46 42 18 68 00
Fax: +46 42 21 88 03

THAILAND

Radicon Transmission (Thailand) Ltd

700/43 Moo 6
Amata Nakorn Industrial Estate
Tumbol Klongtumru
Muang,
Chonburi
20000
Thailand

Tel: +66 3845 9044
Fax: +66 3821 3655

UNITED KINGDOM

Radicon Transmission UK Ltd

Unit J3
Lowfields Business Park,
Lowfields Way, Elland
West Yorkshire, HX5 9DA

Tel: +44 1484 465 800
Fax: +44 1484 465 801

USA

Radicon Drive Systems, Inc.

1599 Lunt Avenue
Elk Grove Village
Chicago
Illinois
60007
USA

Tel: +1 847 593 9910
Fax: +1 847 593 9950

